



**TRAXDA**  
Lift Kits - Made in USA

Toll free: 888-660-5892  
email: info@traxda.com

**SAFETY WARNING!**  
Always use the correct tools, and wear safety goggles. We **STRONGLY** recommend installation by a licensed mechanic on a properly secured locking lift.

Traxda LLC, 810 E 19th Street  
Tucson, Arizona 85719

**TIRE FITMENT ADVICE**  
The best way to ensure proper tire fitment is to install the kit before purchasing your wheels and tires. Always test fit tires and wheels before purchasing.

**VEHICLE RIDE WARNING!**  
Trucks with lift or level kits installed have a higher center of gravity. Aggressive and sudden direction changes may cause a tip over.

**604020 Dodge Ram 1500 5-lug 4x4 Leveling Kit**

- This kit contains:
- 2 - Torsion Keys
- 2 - Shock Brackets
- 1 - Hardware Pack
- Instructions
- Warranty Card
- Stickers



**Installation Tips**

**Always use caution handling ABS or wheel sensor wiring. Avoid tension of any kind on wiring harness as this may cause damage or failure.**

1. Trucks are often not level side to side from the factory. Please measure before installation.
2. Re-torque all hardware to manufactures specifications
3. When aligning, to get the best tire wear use our supplied specifications. OEM specifications are for trucks with stock wheels and tires. Larger tires will wear differently.
4. All instructions are written with vehicle on a 2-post lift with tires removed.

**Step 1**

Remove torsion key adjusting bolt. Using a torsion bar release tool (or similar c-clamp type ball joint press), apply pressure to the torsion key so the keeper nut in the cross member can be removed. Release pressure from torsion key and slide torsion bar forward allowing key to be removed.

**Step 2**

Remove the lower shock mount bolt and install the shock mount bracket using supplied bolt. Reattach the shock using OEM bolt and supplied nut and washer.

**Step 3**

Install TRAXDA torsion key. Using torsion bar tool, apply pressure to torsion key and install keeper and adjusting bolt. **IMPORTANT: the torsion bar must extend completely through key at least 1/4".**

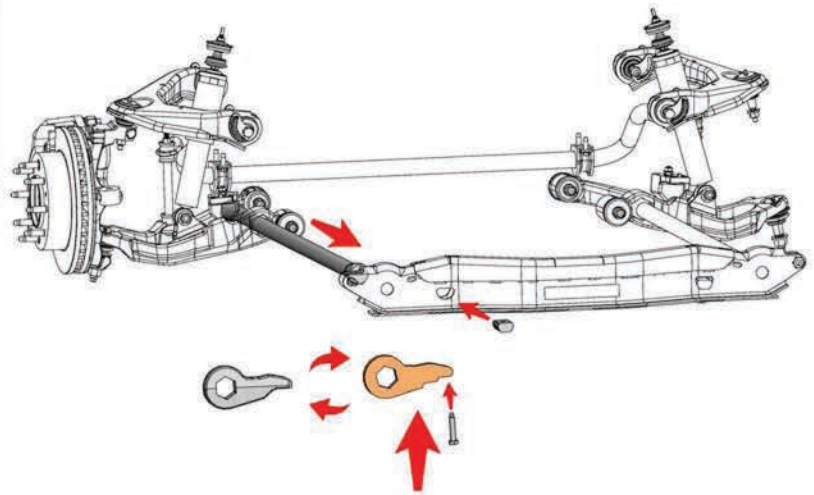

**Figure A:** Illustration is for reference only. Part dimensions will vary from kit to kit.

	Left	Right
Caster (degrees)	2	2.5
Camber (degrees)	0	-1/4 or -.25
Toe	1/32 or .03125 inch toe in	
Special Tools	none	

**Alignment notes:**  
We recommend that a technician with experience doing alignments on lifted trucks perform the alignment. Large tires wear differently than OEM sized tires. Always do an alignment after changing tires on a vehicle.