



TRAXDA
Lift Kits - Made in USA

Toll free: 888-660-5892
email: info@traxda.com

SAFETY WARNING!
Always use the correct tools, and wear safety goggles. We **STRONGLY** recommend installation by a licensed mechanic on a properly secured locking lift.

Traxda LLC, 810 E 19th Street
Tucson, Arizona 85719

TIRE FITMENT ADVICE

The best way to ensure proper tire fitment is to install the kit before purchasing your wheels and tires. Always test fit tires and wheels before purchasing.

VEHICLE RIDE WARNING!

Trucks with lift or level kits installed have a higher center of gravity. Aggressive and sudden direction changes may cause a tip over.

607080 Dodge Dakota & Mitsubishi Raider Leveling Kit

This kit contains:
2 - Strut Caps
1 - Hardware Pack
Instructions
Warranty Card
Stickers



Installation Tips

Always use caution handling ABS or wheel sensor wiring. Avoid tension of any kind on wiring harness as this may cause damage or failure.

1. Trucks are often not level side to side from the factory. Please measure before installation.
2. Re-torque all hardware to manufactures specifications
3. When aligning, to get the best tire wear use our supplied specifications. OEM specifications are for trucks with stock wheels and tires. Larger tires will wear differently.
4. All instructions are written with vehicle on a 2-post lift with tires removed.

Step 1

Disconnect sway bar link at control arm and separate tie rod end. Support spindle assembly. Use caution with any ABS wiring to prevent damage. Separate upper ball joint. Remove lower strut bolt, upper strut mount nuts and remove strut.

Step 2

Install TRAXDA spacer on the strut as shown in Figure A. Note the twisted shape of the TRAXDA cap, the strut will be rotated 180 degrees when reinstalled in the truck.

Step 3

Reinstall the strut assembly in reverse of dis-assembly. It may be necessary to use a pry bar to aid in there-installation of the strut assembly. Use a pit jack to raise the lower control arm* and re-connect ball joint. Verify that all hardware has been tightened to the proper torque specs.

*** A tall jack may be needed under the rear bumper to steady the truck on the lift.**

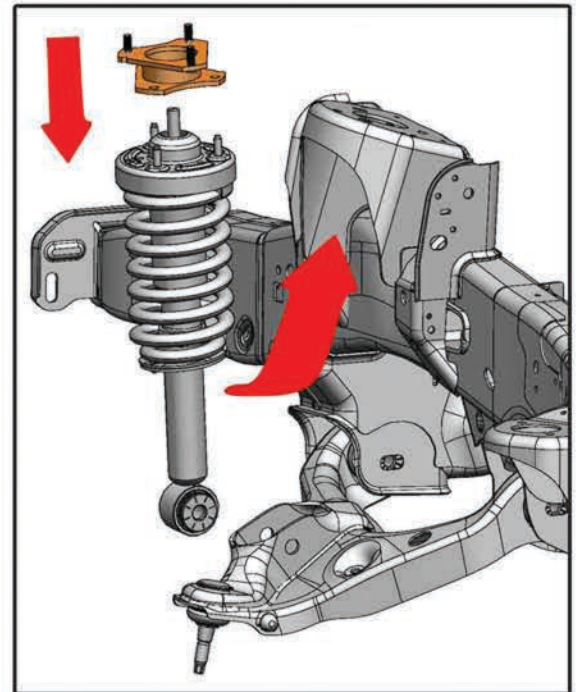

Figure A: Illustration is for reference only. Part dimensions will vary from kit to kit.

Alignment notes:

We recommend that a technician with experience doing alignments on lifted trucks perform the alignment. Large tires wear differently than OEM sized tires. Always do an alignment after changing tires on a vehicle.

	Left	Right
Caster (degrees)	4.24	3.75
Camber (degrees)	0	-1/4 or -.25
Toe	1/32 or .03125 inch toe in	
Special Tools	none	