



TRAXDA
Lift Kits - Made in USA

Toll free: 888-660-5892
email: info@traxda.com

SAFETY WARNING!
Always use the correct tools, and wear safety goggles. We **STRONGLY** recommend installation by a licensed mechanic on a properly secured locking lift.

Traxda LLC, 810 E 19th Street
Tucson, Arizona 85719

TIRE FITMENT ADVICE

The best way to ensure proper tire fitment is to install the kit before purchasing your wheels and tires. Always test fit tires and wheels before purchasing.

VEHICLE RIDE WARNING!

Trucks with lift or level kits installed have a higher center of gravity. Aggressive and sudden direction changes may cause a tip over.

901010 Toyota Sequoia Lift and Level Kit

This kit contains

- 2- Front Preload Spacers
- 2 - Upper Strut Spacers
- 1 - Differential Drop Kit
- 2 - Rear Spacers
- Instructions
- Warranty card
- Stickers



Installation Tips

Always use caution handling ABS or wheel sensor wiring. Avoid tension of any kind on wiring harness as this may cause damage or failure.

1. Trucks are often not level side to side from the factory. Please measure before installation.
2. Re-torque all hardware to manufactures specifications
3. When aligning, to get the best tire wear use our supplied specifications. OEM specifications are for trucks with stock wheels and tires. Larger tires will wear differently.
4. All instructions are written with vehicle on a 2-post lift with tires removed.

Step 1

Loosen bolts attaching the lower control arm to frame. Disconnect sway bar links from lower control arm. Remove lower strut bolt and remove bolts at lower ball joint allowing the lower control arm to swing down and out of the way. Remove upper strut mount nuts and remove strut.

Step 2

Mark the strut for proper re-assembly. Using a spring compressor tool, disassemble the strut and install the TRAXDA spacer. It may be necessary to use a pry bar to aid in the re-installation of the strut assembly, and a pit jack to raise the lower control arm. Verify that all hardware has been tightened to the proper torque specs.

Step 3

To install differential drop, first remove the inspection cover. Support the differential with a jack, remove the 2 long front mounting bolts. Place the supplied spacers between the mount and frame, secure using supplied long bolts and nuts. Reinstall inspection cover.

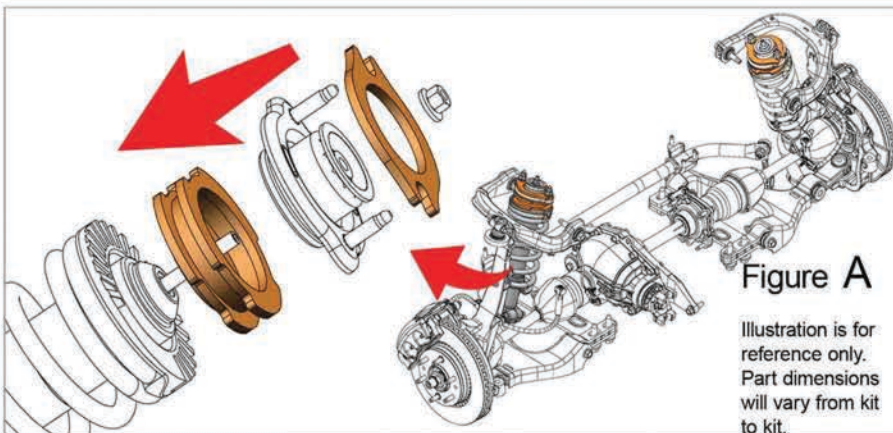

Figure A

Illustration is for reference only. Part dimensions will vary from kit to kit.

Instructions continued on back



TRAXDA
Lift Kits - Made in USA

Toll free: 888-660-5892
email: info@traxda.com

SAFETY WARNING!
Always use the correct tools, and wear safety goggles. We **STRONGLY** recommend installation by a licensed mechanic on a properly secured locking lift.

Traxda LLC, 810 E 19th Street
Tucson, Arizona 85719

TIRE FITMENT ADVICE
The best way to ensure proper tire fitment is to install the kit before purchasing your wheels and tires. Always test fit tires and wheels before purchasing.

VEHICLE RIDE WARNING!
Trucks with lift or level kits installed have a higher center of gravity. Aggressive and sudden direction changes may cause a tip over.

901010 Toyota Sequoia TRAXDA Installation Instructions (cont.)

Rear Installation

Support the weight of the rear axle and remove one rear shock. Be careful of the brake hoses they will be at maximum extension while installing this piece. With the shock removed the spring should come out easily. Install the TRAXDA spring spacer into the vehicle as shown in Figure B using the supplied 10mm bolt. Fit the cone shaped bump stop onto the spacer and have an assistant use a pry bar to lever the spring back into place. Reinstall the shock and repeat on the other side.

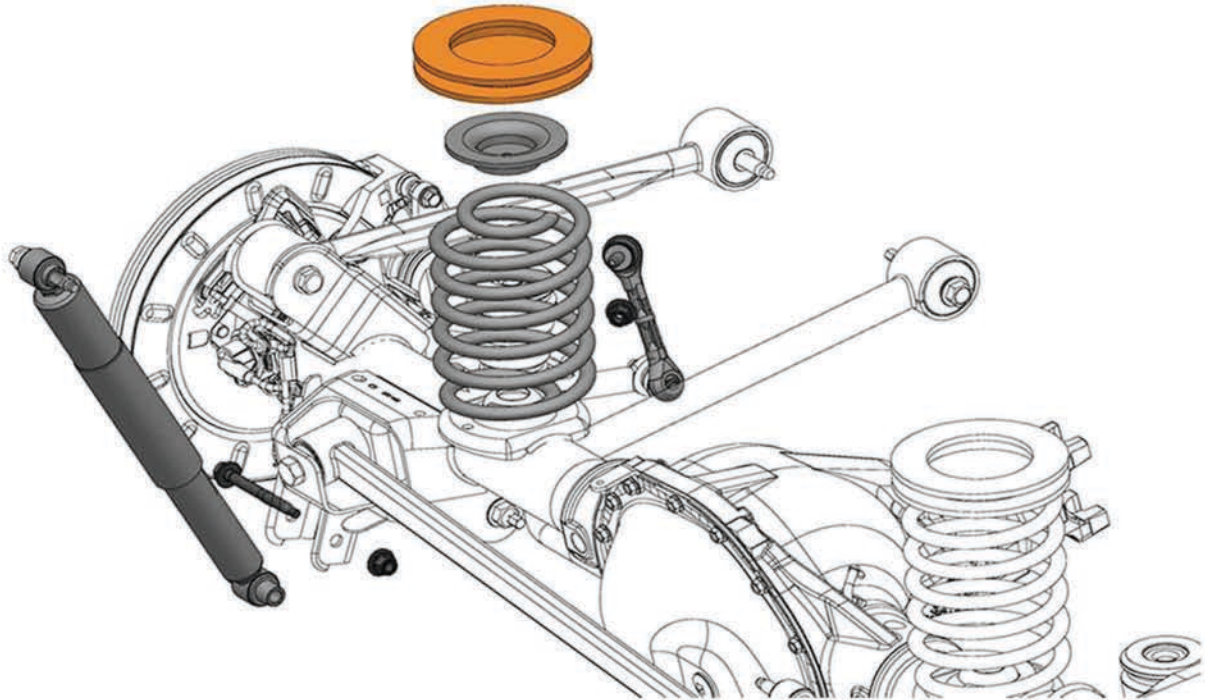

Alignment notes:

We recommend that a technician with experience doing alignments on lifted trucks perform the alignment. Large tires wear differently than OEM sized tires. Always do an alignment after changing tires on a vehicle.

	Left	Right
Caster (degrees)	2.5	2.75
Camber (degrees)	0	-.25
Toe	.0312	
Special Tools	none	