

406085 LIFT/LEVEL KIT

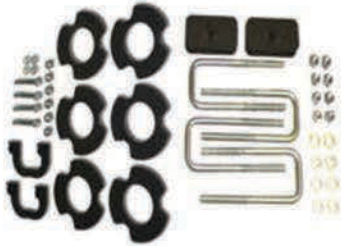

2007-2014 Chevrolet/GMC 1500 4x2

6-Lug, front coil-over/rear leaf



THIS KIT CONTAINS

- Lower Strut Spacers (x2)
- Upper Strut Spacers (x6)
- Hardware Pack (x1)
- Rear Lift Blocks (x2)
- U-Bolts (x4)
- U-Bolt Hardware Pack (x1)

Instructions
Stickers

Special Notes

- This kit includes six (6) upper strut spacers (3 for each side) that are used for adjusting the front ride height. Each plate will lift the front approx. 1/2". To achieve maximum lift use 3 plates per side.
- On 4x4 models you must remove the drive axle nut. **Failure to follow this step may cause damage to axle CV joint.**

Front Installation

- Loosen and remove the upper ball joint nut, tie rod nut, and sway bar nut. A hammer may be needed to break the ball joint and tie rod free.
- Remove the strut from the vehicle, install the three supplied spacers on top of the strut. Reinstall the upper strut and secure with the **new** hardware provided. The OEM hardware will not work.
- Install the lower U-shaped spacer supplied with the kit as shown in Figure A. Use the hardware provided. The OEM bolts will not work. A pry bar will be needed or the axle will hyper extend and cause damage.
- Install lower strut mount with bolts that are included in the kit. The OEM bolts will not work. Using the pry bar, reinstall the upper ball joint and nut. Reinstall the axle nut. Install the remaining upper strut mount nuts and reinstall the sway bar link.



Figure A: Illustration is for reference only. Part dimensions will vary.

SAFETY WARNING

Always use the correct tools and wear safety goggles. We strongly recommend installation by a licensed mechanic on a properly secured locking lift.

VEHICLE RIDE WARNING

Trucks with lift or level kits installed will have higher centers of gravity than stock. Aggressive driving and sudden direction changes can cause an unexpected rollover.

TIRE FITMENT ADVICE

The best way to ensure proper tire fitment is to install the kit before purchasing your wheels and tires. Always test fit tires and wheels before purchasing.

INSTALLATION TIPS:

Trucks are often not level side to side from the factory. Always measure before installation.

Always re-torque all hardware to the manufacturer's original specifications.

In order to get the best tire wear, use our supplied alignment specifications. OEM specifications are for trucks with stock wheels and tires. Larger tires will wear differently.

All instructions are written for vehicle on a two-post lift with tires removed.

Always use caution when handling ABS or wheel sensor wiring. Avoid tension of any kind on wiring harness as this may cause damage or failure.

Rear Installation

- Disconnect ABS wires so they can droop. Loosen lower shock bolt and remove. Use pit jack to support the differential. Remove U-bolts from one side of the truck only. This will help keep the differential steady. Remove factory block and install TRAXDA lift block between differential and leaf spring as shown in illustration below. Install U-bolts supplied with TRAXDA kit. Reinstall lower shock bolts. Repeat on the other side of the truck.

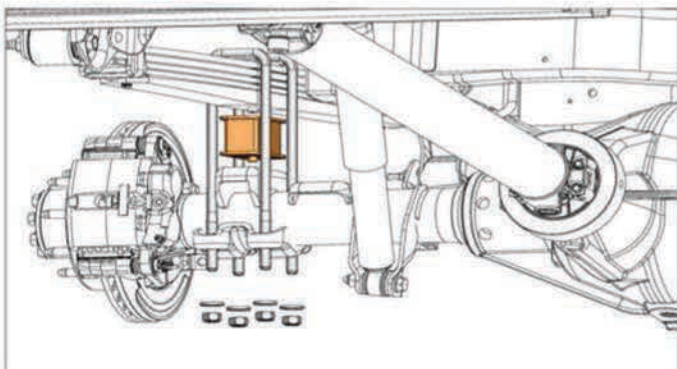

Alignment Notes:

We recommend that a technician with experience doing alignments on lifted trucks perform the alignment. Large tires wear differently than OEM sized tires. Always do an alignment after changing tires on a vehicle.

	Left	Right
Caster (degrees)	2	2.5
Camber (degrees)	0	-.250
Toe	1/16 or .0625 inch toe in	
Special Tools	none	