



**TRAXDA**  
Lift Kits - Made in USA

**Toll free: 888-660-5892**  
**email: info@traxda.com**

**SAFETY WARNING!**  
Always use the correct tools, and wear safety goggles. We **STRONGLY** recommend installation by a licensed mechanic on a properly secured locking lift.

**Traxda LLC, 810 E 19th Street**  
**Tucson, Arizona 85719**

**TIRE FITMENT ADVICE**

The best way to ensure proper tire fitment is to install the kit before purchasing your wheels and tires. Always test fit tires and wheels before purchasing.

**VEHICLE RIDE WARNING!**

Trucks with lift or level kits installed have a higher center of gravity. Aggressive and sudden direction changes may cause a tip over.

**707057 Nissan Titan Lift Kit**

This kit contains:

- 2 - Strut Caps
- 2 - Shim Spacers
- 1 - Hardware Pack
- 2 - Rear Lift Blocks
- 4 - U-Bolts
- 1 - U-bolt Hardware Pack
- Instructions
- Warranty Card
- Stickers



**Installation Tips**

**Always use caution handling ABS or wheel sensor wiring. Avoid tension of any kind on wiring harness as this may cause damage or failure.**

1. Trucks are often not level side to side from the factory. Please measure before installation.
2. Re-torque all hardware to manufactures specifications
3. When aligning, to get the best tire wear use our supplied specifications. OEM specifications are for trucks with stock wheels and tires. Larger tires will wear differently.
4. All instructions are written with vehicle on a 2-post lift with tires removed.

**Front Installation**

**Step 1**

Disconnect sway bar links and upper ball joint nut. Support spindle assembly and use caution with ABS wires so they do not get damaged. Separate upper ball joint. Remove lower strut bolt, upper strut mount nuts and remove strut.

**Step 2**

Install TRAXDA spacer on the strut as shown in Figure A. Note: The supplied spacer will be needed on Titan's with 17mm and 18mm diameter coil springs. The spacer will fit on top of the Traxda cap. If the truck is equipped with 19mm coil springs, the spacer cannot be used.

**Step 3**

Note the twisted shape of the TRAXDA cap, the strut will be rotated 180 degrees when reinstalled in the truck. Reinstall the strut assembly in reverse of disassembly. It may be necessary to use a pry bar to aid in the re-installation of the strut assembly, and a pit jack to raise the lower control arm. Verify that all hardware has been tightened to the proper torque specs.

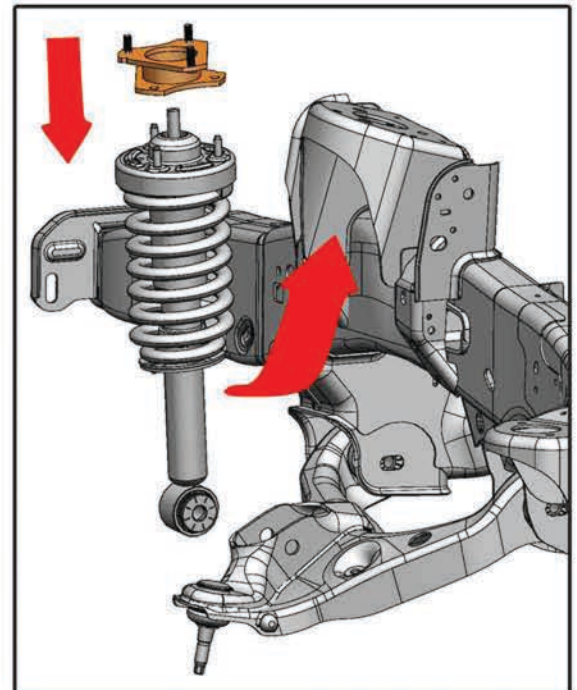

**Figure A:** Illustration is for reference only. Part dimensions will vary from kit to kit.

Instructions continued on back



**TRAXDA**  
Lift Kits - Made in USA

**Toll free: 888-660-5892**  
**email: info@traxda.com**

**SAFETY WARNING!**  
Always use the correct tools, and wear safety goggles. We **STRONGLY** recommend installation by a licensed mechanic on a properly secured locking lift.

**Traxda LLC, 810 E 19th Street**  
**Tucson, Arizona 85719**

**TIRE FITMENT ADVICE**  
The best way to ensure proper tire fitment is to install the kit before purchasing your wheels and tires. Always test fit tires and wheels before purchasing.

**VEHICLE RIDE WARNING!**  
Trucks with lift or level kits installed have a higher center of gravity. Aggressive and sudden direction changes may cause a tip over.

## 707057 Instructions Continued

### Rear Installation

#### Step 4

Disconnect ABS wires so they can droop. Loosen lower shock bolt and remove. Use a pit jack to support the differential. Remove U-bolts from one side of the truck only. This will help keep the differential steady. Install lift block between differential and leaf spring. Install U-bolts supplied with TRAXDA kit. Re-install lower shock bolts. Repeat on the other side of the truck.

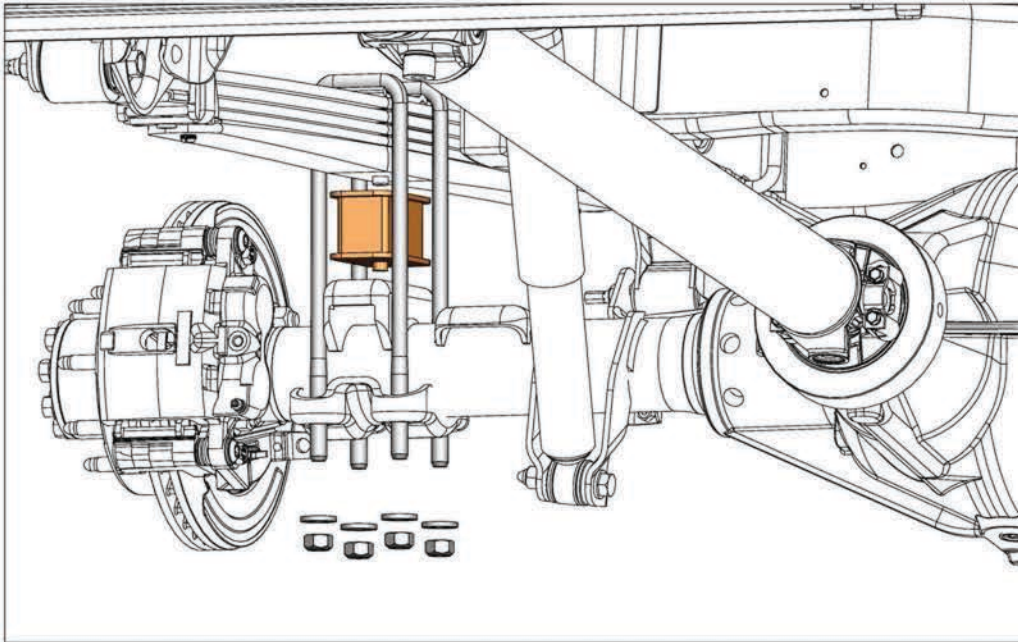

**Torque U-bolt hardware to 75 ft. lbs.**  
**Never reuse U-bolts**

#### Alignment notes:

We recommend that a technician with experience doing alignments on lifted trucks perform the alignment. Large tires wear differently than OEM sized tires. Always do an alignment after changing tires on a vehicle.

	Left	Right
Caster (degrees)	2.5	2.75
Camber (degrees)	0	-1/4 or -.25
Toe	1/32 or .03125 inch toe in	
Special Tools	none	