



**CHEVY COLORADO
GMC CANYON
BODY LIFT
INSTALLATION INSTRUCTIONS
2008 3" KIT # 10223**

⚠ WARNING
This kit should only be installed on a vehicle that is in good working condition. Before you install the kit, thoroughly inspect the vehicle for corrosion or deformation of the sheet metal around the factory body mounts. If the vehicle is suspected to have been in a collision or misused, do not install this kit. Off-road use of your vehicle with this kit installed may increase the stress applied to the factory body mounts. We do not recommend that any vehicle with a body lift kit installed be involved in any extreme off-road maneuvers such as jumping. Failure to observe this warning may result in serious personal injury and/or severe damage to your vehicle.

⚠ WARNING
Many states and municipalities have laws restricting bumper heights and vehicle lifts. Consult state and local laws to determine if the changes you intend to make to the vehicle comply with the law. Before combining a body lift with a suspension lift, consult an installation professional to see how this will affect the vehicle.

⚠ WARNING
The installation of larger tires may reduce the effectiveness of the Braking System.

⚠ WARNING
Always wear eye protection when operating power tools.

⚠ WARNING
Before you install this kit, block the vehicle tires to prevent the vehicle from rolling.

⚠ WARNING
Accidental deployment of the air bag can result in serious personal injury or death. To avoid accidental deployment during installation of the kit, the Supplemental Restraint System (SRS, or airbag) must remain deactivated. Do not allow anyone near the airbag during installation. Refer to the factory service manual or owner's manual for the recommended procedure to disable the SRS. After you install the kit, reactivate the SRS before driving the vehicle.

⚠ NOTE
Performance Automotive Group recommends using the Loctite® supplied in the kit on the threads of all kit nuts and bolts unless specified otherwise in these instructions.

⚠ WARNING
Installation of a Performance Automotive Group body lift kit will change the vehicle's center of gravity and handling characteristics both on- and off-road. You must drive the vehicle safely! Extreme care must be taken to prevent vehicle rollover or loss of control, which could result in serious injury or death. Avoid sudden sharp turns or abrupt maneuvers and always make sure all vehicle occupants have their seat belts fastened.

⚠ WARNING
Before you install this kit, read and understand all instructions, warnings, cautions, and notes in this instruction sheet and in the vehicle owner's manual.

⚠ CAUTION
Proper installation of this kit requires knowledge of the factory recommended procedures for removal and installation of original equipment components. We recommend that the factory shop manual and any special tools needed to service your vehicle be on hand during the installation. Installation of this kit without proper knowledge of the factory recommended procedures may affect the performance of these components and the safety of the vehicle. We strongly recommend that a certified mechanic familiar with the installation of similar components install this kit.

Before Starting Installation

⚠ NOTE

Kit parts are prefaced by the word kit and appear in **bold** print.

1. Carefully read all warnings and instructions completely before beginning.
2. Verify all parts have been received in this kit by checking the parts list at the end of this document.

⚠ NOTE

If parts are missing from kit, please be prepared to provide the following information:

1. **Name** of purchase location
2. **Bar Code** on side of box
3. **Date** above bar code
4. **Date** inside box cover
5. **Inspector #** from inside box cover

3. **Only install this kit on the vehicle for which it is specified.** If anytime during the installation you encounter something different from what is outlined in the instructions, call technical support at (928) 636-7080.
4. Special tools needed:
 - a. Welder or access to a professional welding shop.
 - b. Die grinder or similar tool capable of cutting metal.
 - c. Fan clutch spanner wrench.
5. Park the vehicle on a clean, dry, flat, level surface and block the tires so the vehicle cannot roll in either direction.

Measurements

1. Measure and record distance between front bumper and fenders.

Driver Side ____ Passenger Side ____

2. Measure and record distance between rear bumper and bed

Driver Side ____ Passenger Side ____

3. Measure and record distance between cab and bed.

Driver Side ____ Passenger Side ____

Engine Compartment

1. Battery Cables.
 - a. Disconnect both battery cables. Disconnect negative cable first, then positive cable.

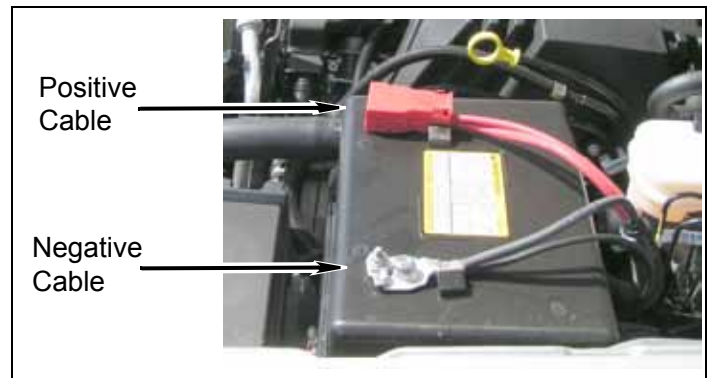

2. Airbag Fuse.

⚠ NOTE

The location of the airbag fuse may vary; check the owner's manual.

- a. Remove fuse box cover.
- b. Remove airbag fuse from fuse box.

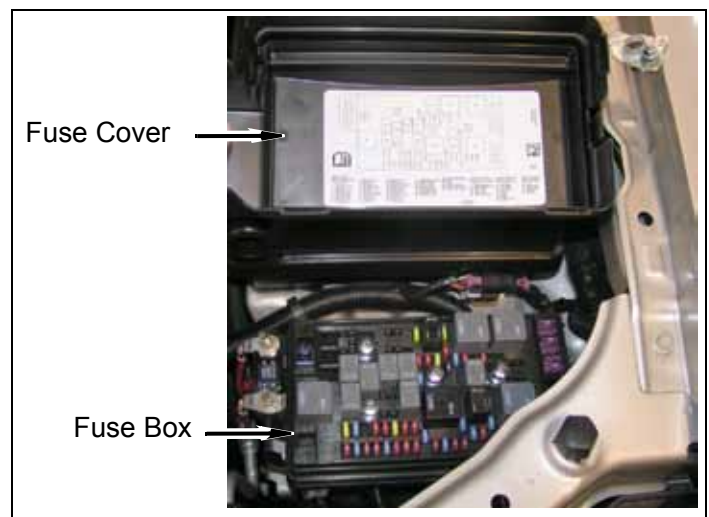

Prepare to Install Kit

Front of Vehicle

1. Grille

- a. Remove two wire harness clips from upper headlamps.

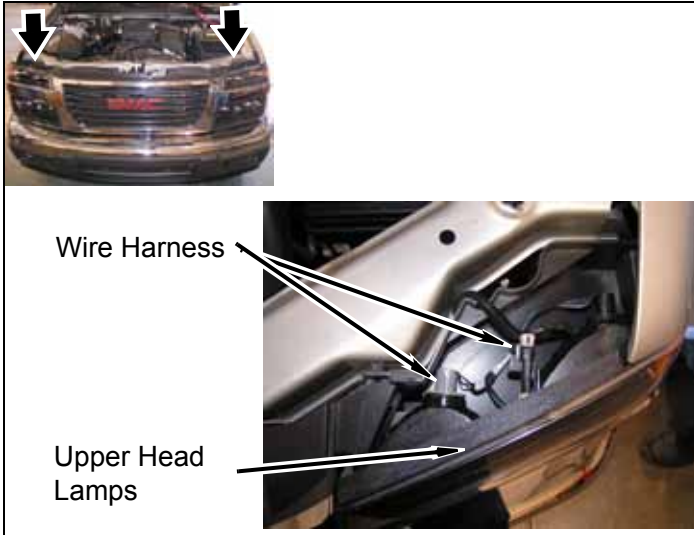

- b. Release four push down clips from upper grille area.

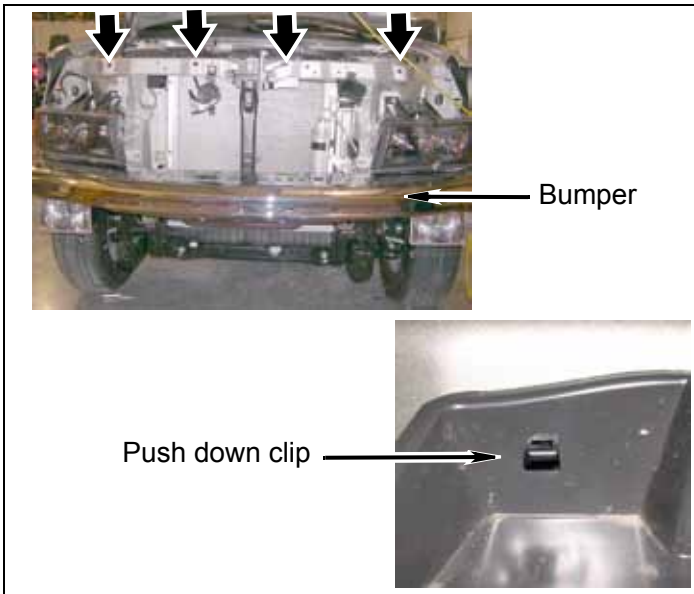

- c. Remove seven clips and grille from vehicle.

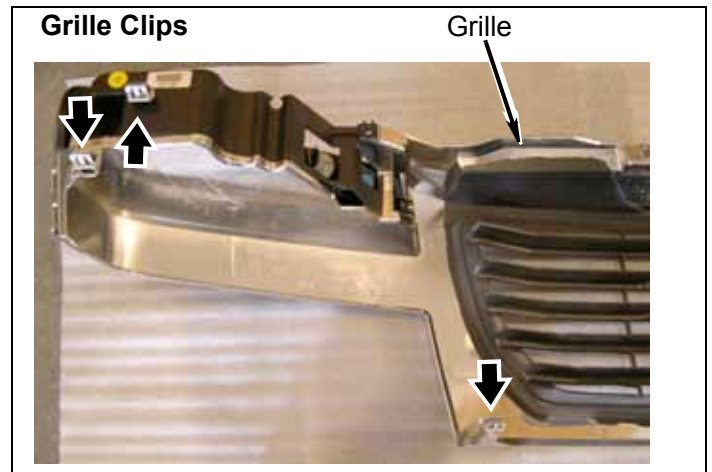

2. Running Lights

- a. Remove two wire harness connectors from running lights.

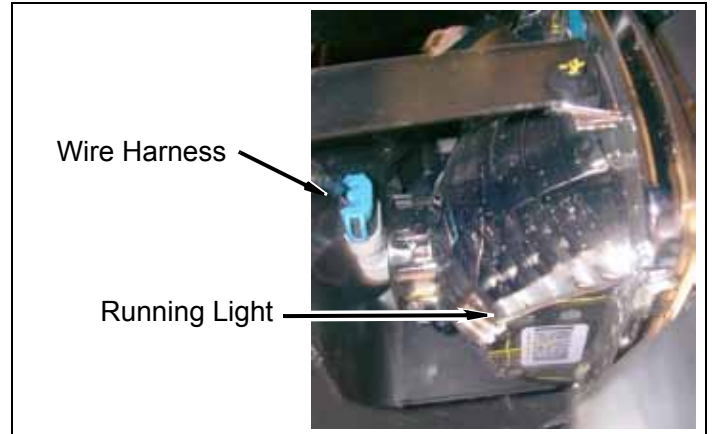

3. Front Bumper

- a. Remove four bolts and bumper side brace from frame.

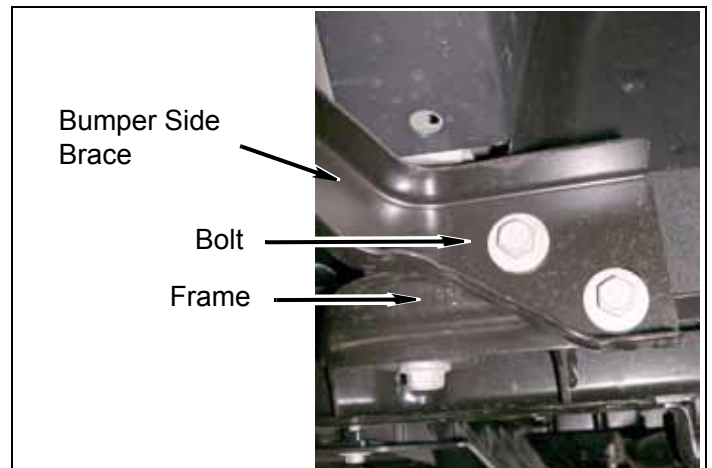

b. Remove four bolts and bumper from frame.

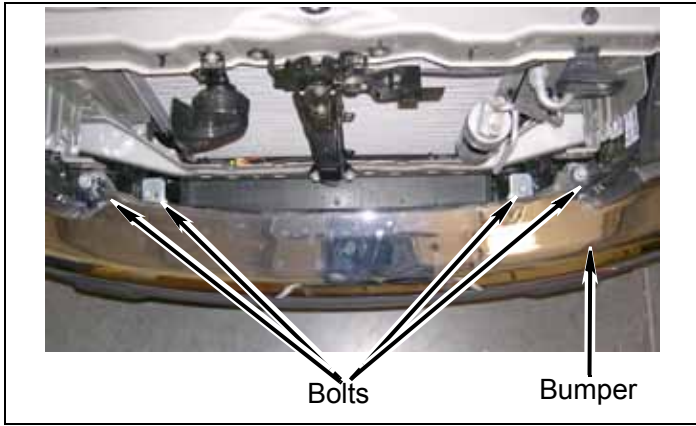

c. Remove four bolts and splash shield from undercarriage.

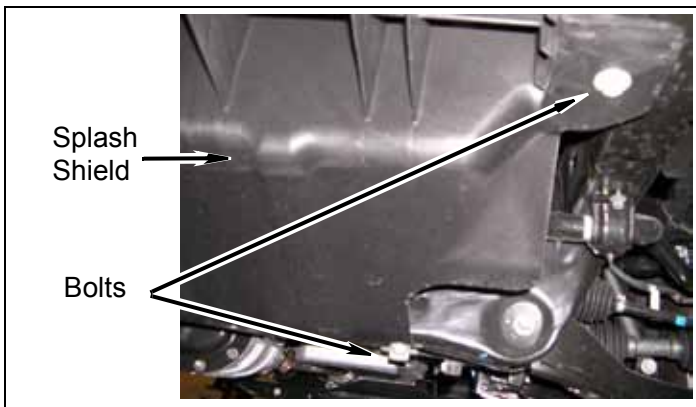

Engine Compartment

1. Fresh Air Intake Hose

a. Loosen two clamps and remove fresh air intake hose.

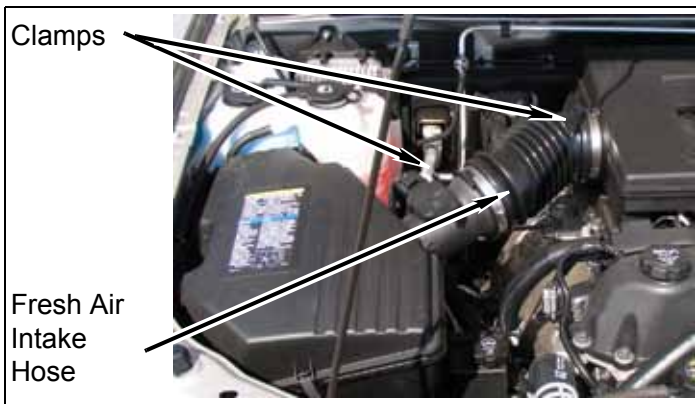

2. Remove air pump hose leading into air box from below.

3. Steering Shaft

⚠ WARNING

Accidental deployment of the air bag can result in serious personal injury or death. To avoid accidental deployment during installation of the lift kit, the Supplemental Restraint System (SRS, or airbag) must remain deactivated. Do not allow anyone near the airbag during installation. Refer to the factory service manual or owner's manual for the recommended procedure to disable the SRS. After kit installation, the SRS must be reactivated before driving the vehicle.

⚠ CAUTION

If the following step is not performed, the airbag clockspring could be damaged. Do not turn the steering wheel while the steering shaft is disconnected.

- Strap steering wheel to prevent accidental movement.
- Mark the steering intermediate shaft and u-joint coupler as shown.
- Remove bolt and intermediate shaft from u-joint coupler.

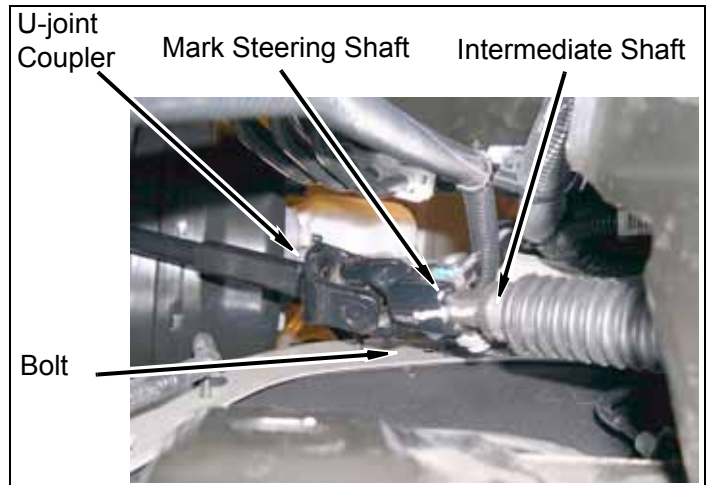

4. Wire Harness and Line Clips

a. **Driver side:** Remove two clips from upper fender well.

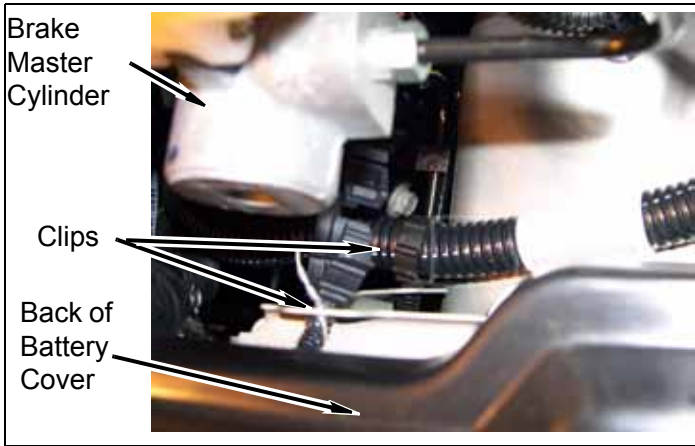

b. Remove clip from battery box.

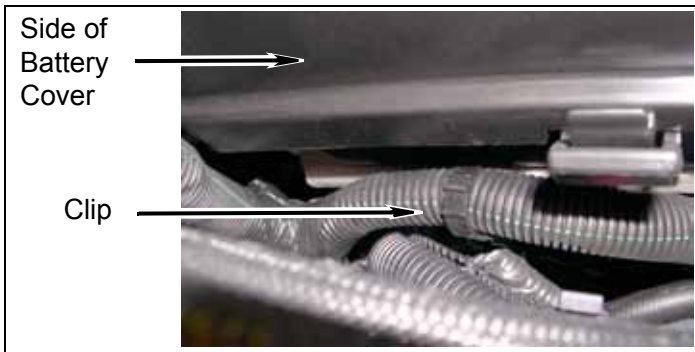

c. Remove brake line clip from fender well.

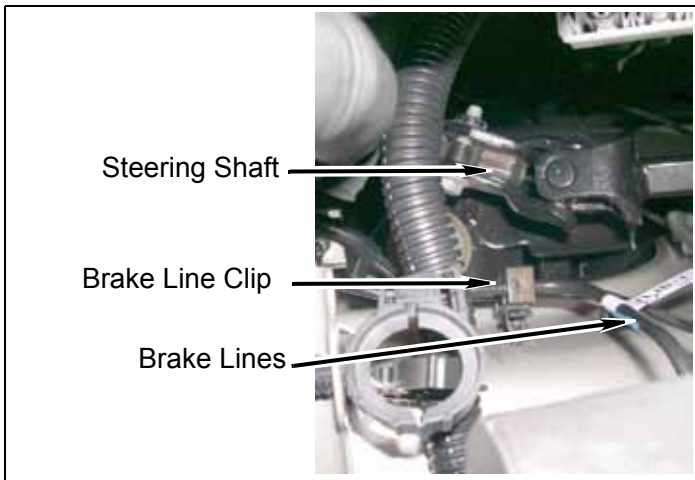

d. Remove a/c line clip from upper fan shroud.

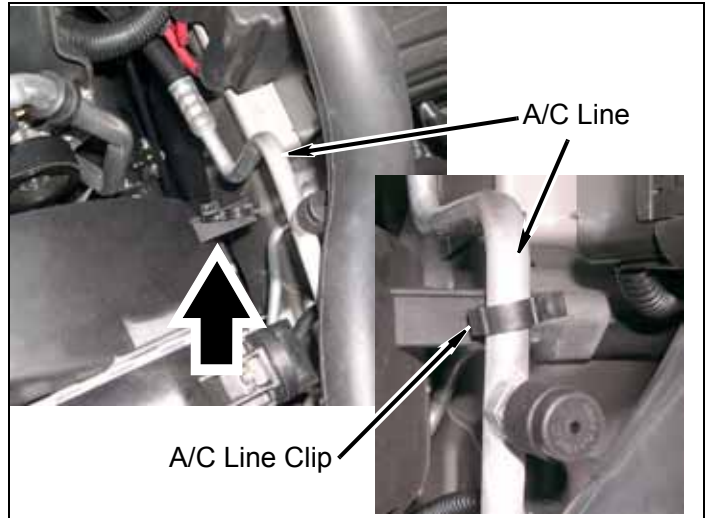

e. **Passenger side:** Remove wire harness from clip and power steering reservoir.

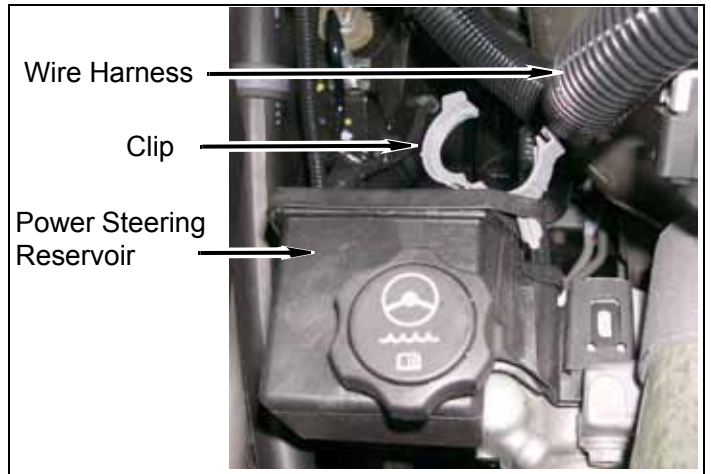

f. Remove brake line from clip on fender well.

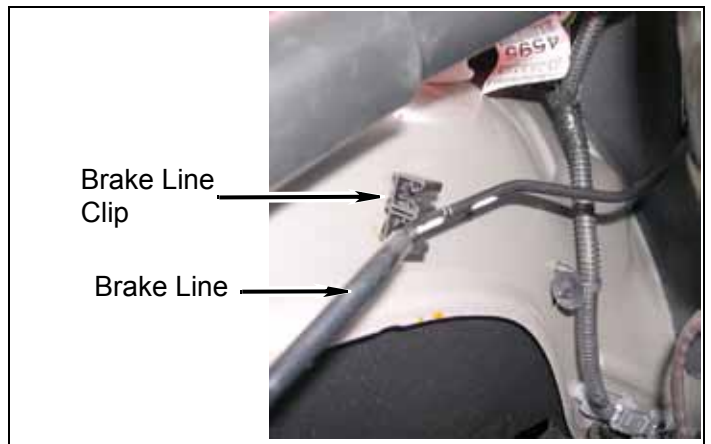

g. Remove wire harness and vent hose clip from fender well.

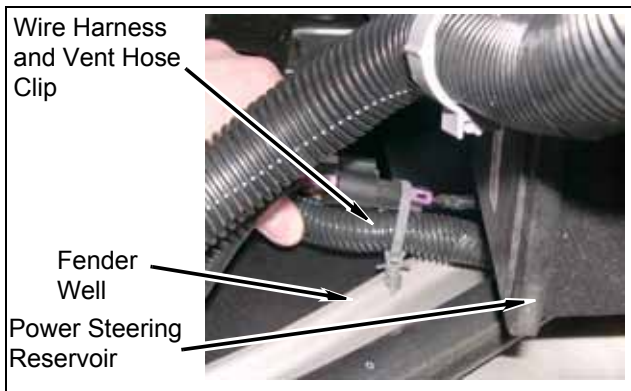

b. Remove two bolts and separate condenser from radiator.

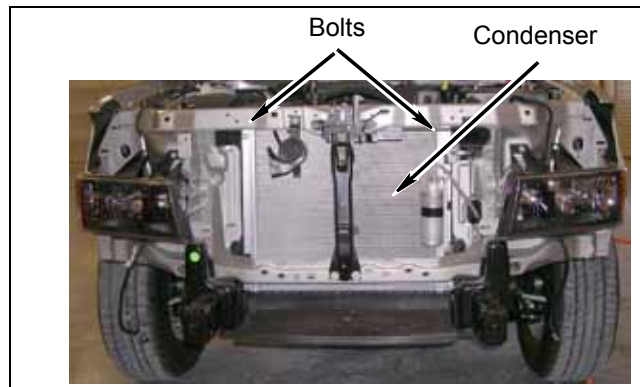

h. Remove a/c line from clip on upper fan shroud. Remove hose from clip at upper fan shroud.

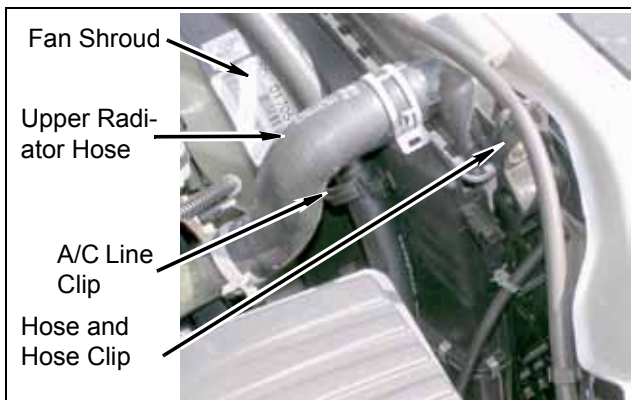

c. **Passenger Side:** Tie condenser to core support with kit zip tie as shown.

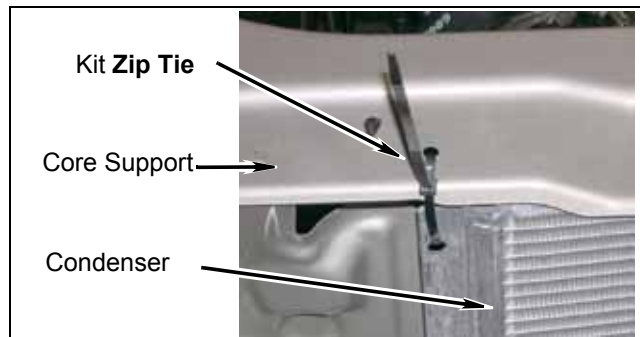

5. Fan Shroud

a. Remove bolt and upper radiator center mount bracket from core support and radiator.

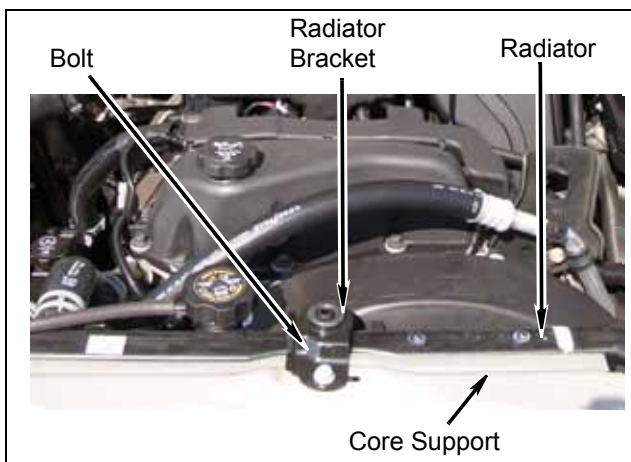

⚠WARNING

If the engine cooling system is hot, the coolant will be HOT and UNDER PRESSURE. To prevent serious personal injury, wait until the cooling system is completely cool before removing the cap from the radiator.

- d. Remove upper radiator hose from radiator making sure to catch the coolant in a drain pan. Use a kit **zip tie** to hold radiator hose out of way. Place a plastic bag over radiator outlet to keep coolant from leaking.

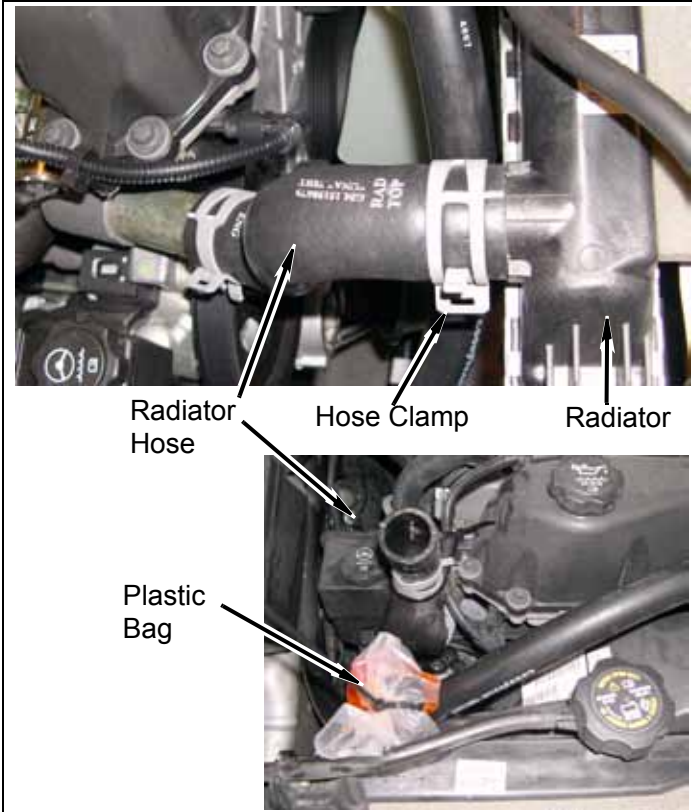

- e. Remove six clips and upper fan shroud from vehicle.

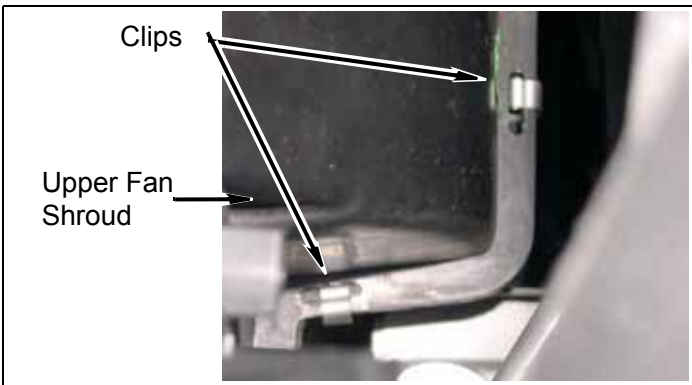

- f. Remove two bolts from pulley to allow spanner wrench to be used.

- g. Remove fan and fan clutch assembly from vehicle using a spanner wrench.

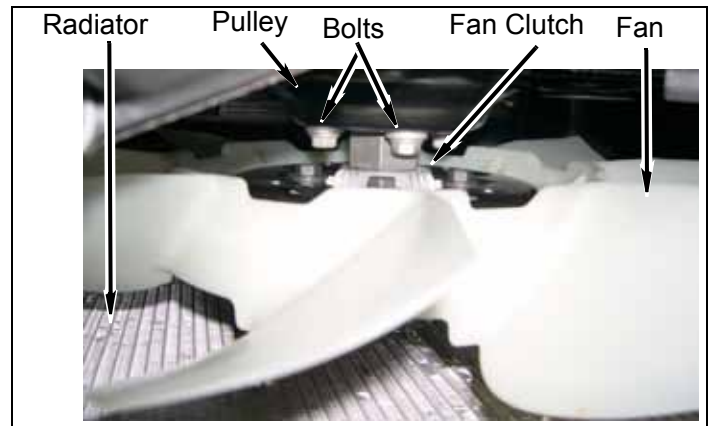

- h. Remove lower fan shroud and fan shroud ring from vehicle.

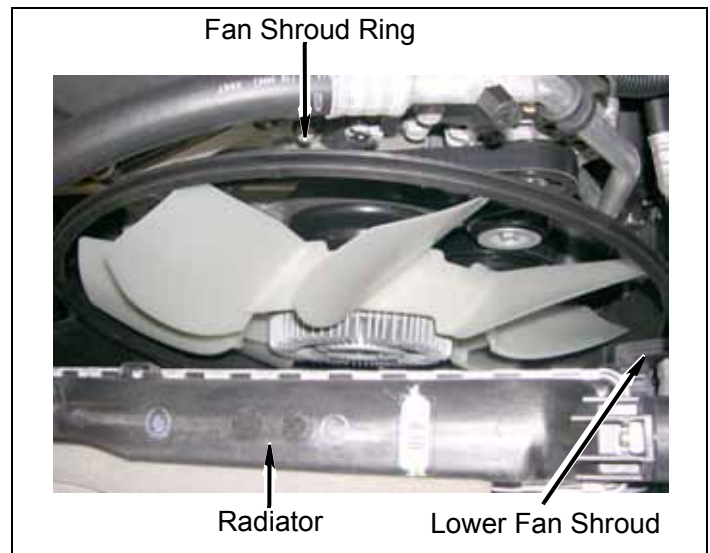

- i. Lift radiator from lower mounting locations and rest on frame making sure to watch all a/c, transmission cooler lines and hoses.

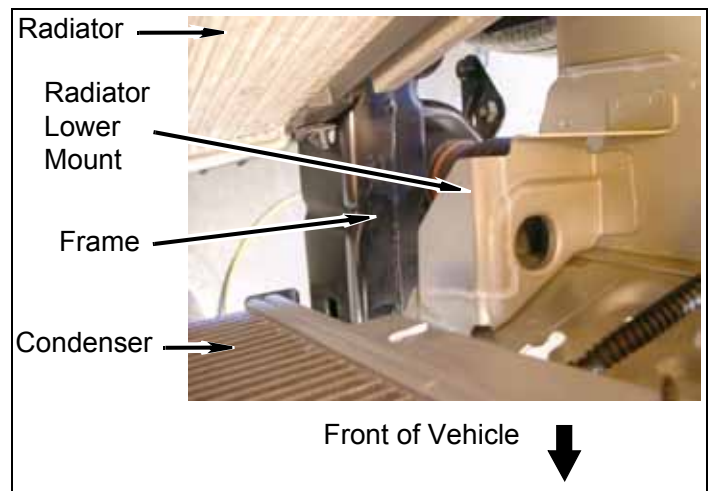

Underside of Vehicle

1. Ground Strap

- a. Remove bolt and ground strap from cab passenger side.

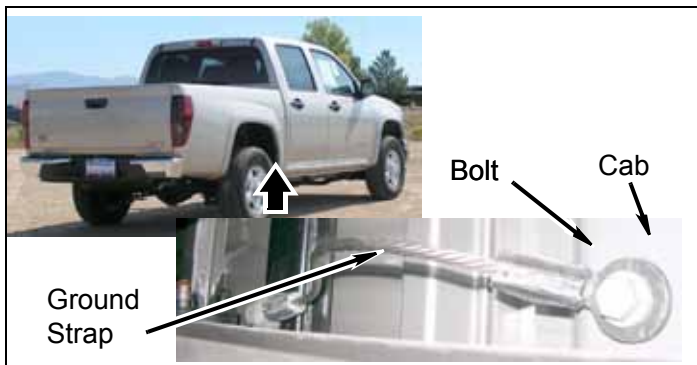

- b. Remove license plate light wire harness from wire harness connector on rear bumper
- c. Remove trailer tow wire harness clip from bumper.

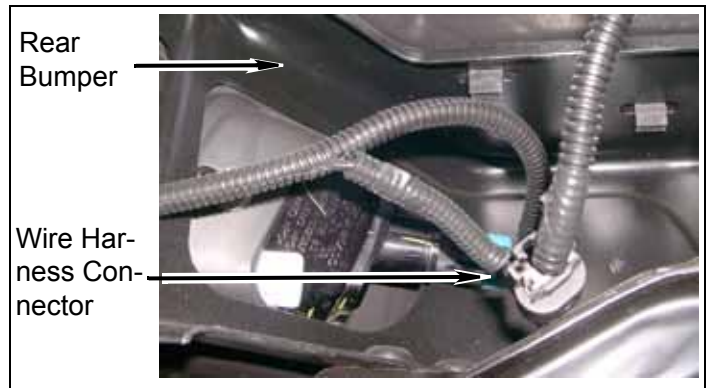

Rear of Vehicle

1. Fuel Filler

- a. Remove fuel cap, bolt and fuel filler from bed.

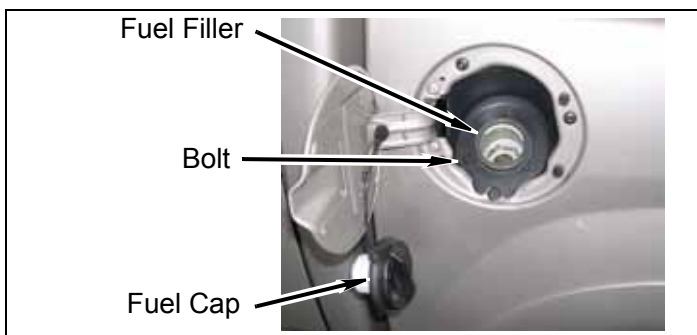

- d. **Driver Side:** Remove five bolts from bumper bracket, frame and bumper.

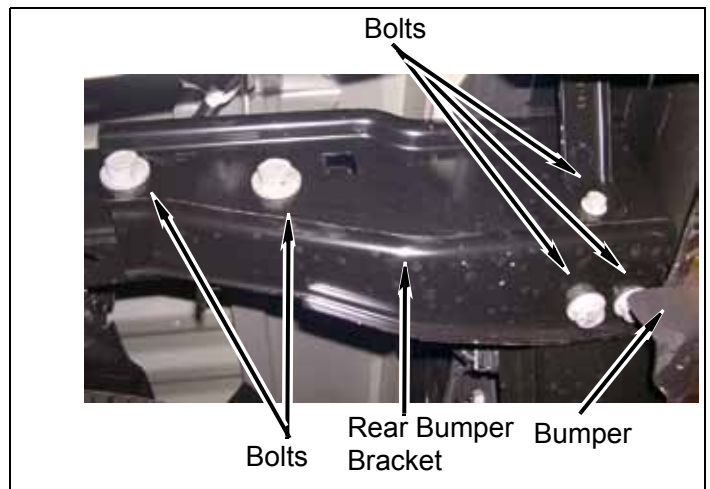

2. Spare Tire

- a. Remove spare tire (refer to Owner's Manual).

3. Rear Bumper

- a. **Driver side:** Remove wire harness from clip and rear bumper bracket.

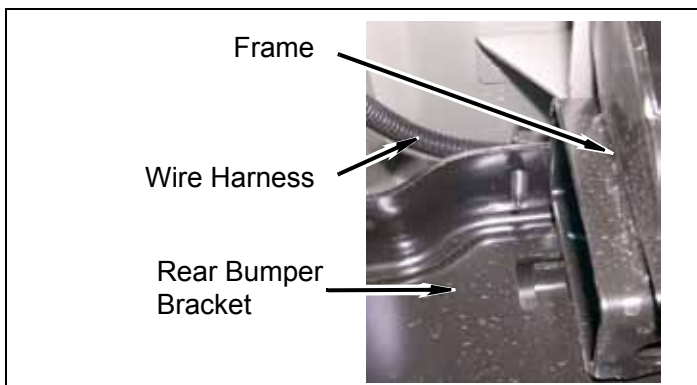

- e. **Driver Side:** Remove cover plate from top of rear bumper by squeezing four plastic tabs.

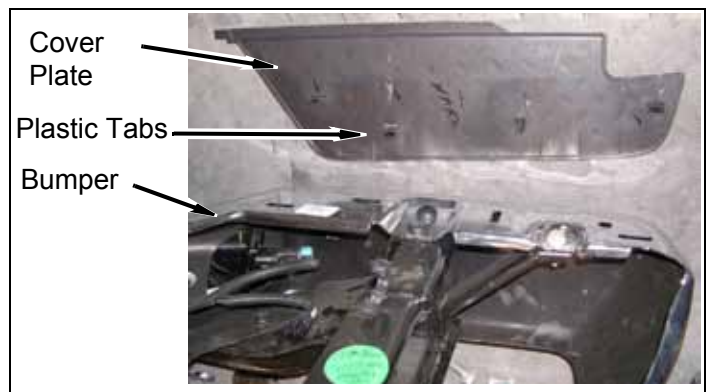

- f. Remove two torx bolts and loosen bolt holding brace to bumper. Remove bumper bracket from frame and bumper making sure to support this end.

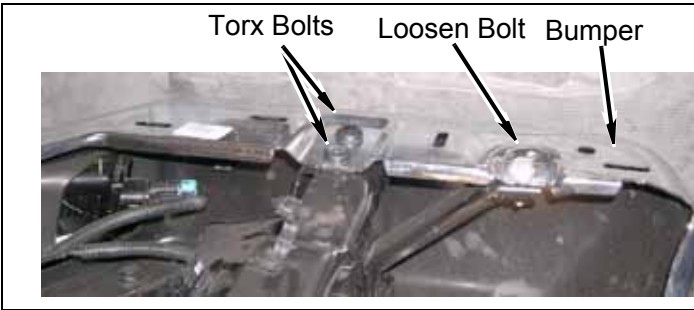

⚠CAUTION
Use caution when removing the bumper. Make sure not to scratch the truck bed.

- g. **Passenger Side:** Remove two bolts from bumper bracket and frame. Remove bumper and bumper bracket from vehicle.

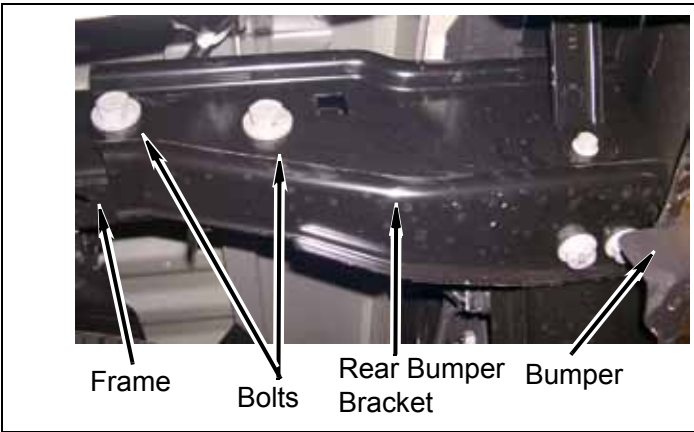

Install Kit

Cab

1. Lift cab

- a. Loosen, but DO NOT remove, cab mounting bolts on driver side (three bolts on vehicles with regular cab; four bolts on vehicles with extended or crew cab).

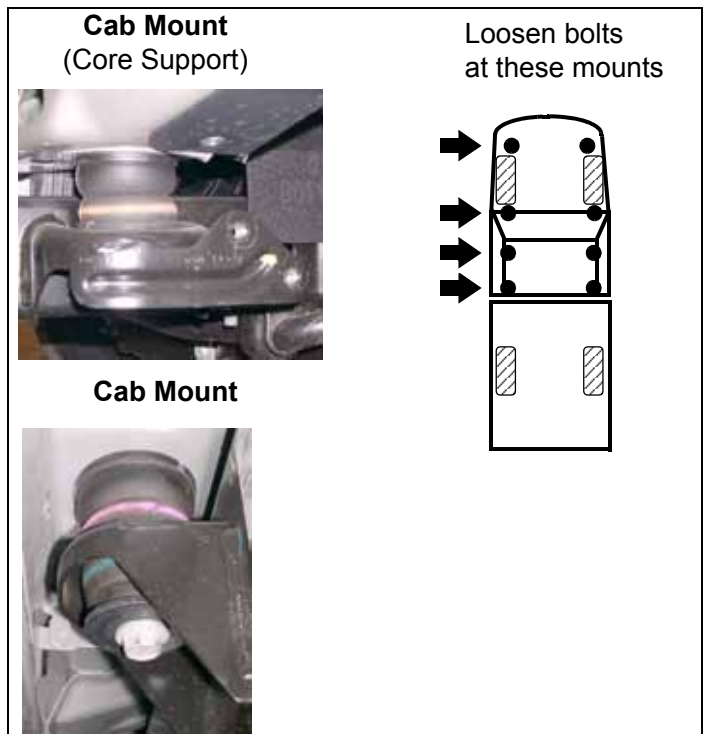

- b. Remove bolt and lower bushing from each cab mount on passenger side.

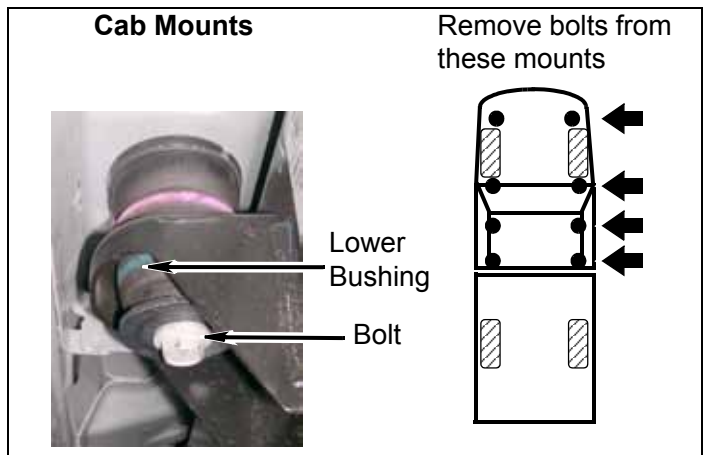

⚠ WARNING
Use extreme caution when lifting body from frame. To prevent serious personal injury, ensure the lifting device is securely placed. Keep your hands out from between the body and frame.

⚠CAUTION

Continually check hoses, wires, lines, etc. to be sure that everything is flexing properly and not binding, or damage to the vehicle could result. Be especially careful of the a/c hoses at the fire wall, the belt pulley, and at the core support. Ensure brake lines stretch while lifting. Bending the lines to gain ample slack may be necessary. Be extremely careful not to kink the lines.

2. Cab passenger side.

- a. Using a hydraulic jack and a wooden block, slowly lift passenger side of cab a little more than 3".

⚠ WARNING

The kit **blocks** must be installed in addition to the factory upper and lower bushings. Installing the kit **blocks** without the factory upper and lower bushings could result in damage to the vehicle or serious personal injury.

- b. Install kit **blocks** (3" x 3") on upper bushings on each cab mount.

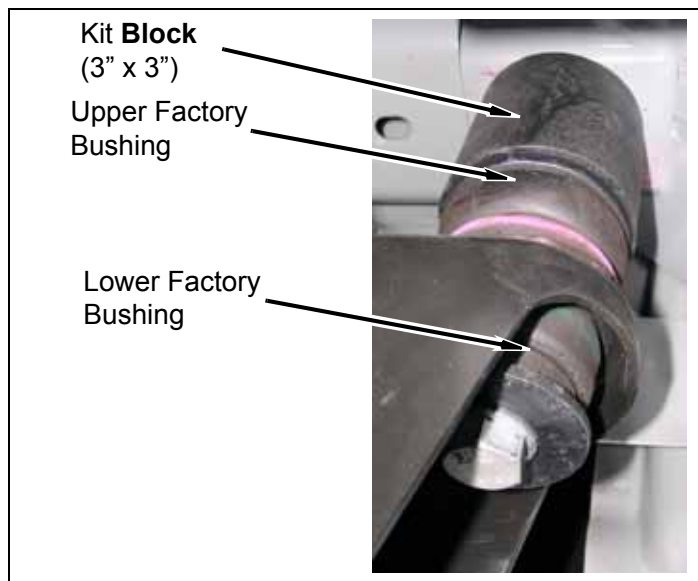

- c. Lower cab onto kit **blocks** (3" x 3").

- d. Install lower bushing and a kit **bolt** (14mm x 200mm) on each cab mount. **DO NOT** tighten.

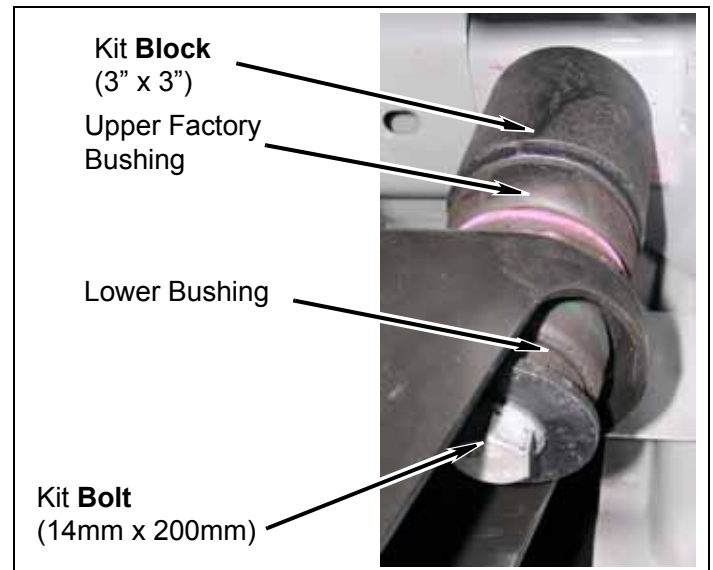

3. Cab driver side

- a. Repeat previous steps on driver side of cab.
- b. Set cab-to-bed spacing according to previous measurement.
- c. Remove each kit **bolt** (14mm x 200mm), one at a time, and apply a few drops of Loctite® to threads. Install kit **bolt** (14mm x 200mm), kit **washer** (14mm), and lower bushing. Tighten kit **bolt** to 55 ft. lbs.

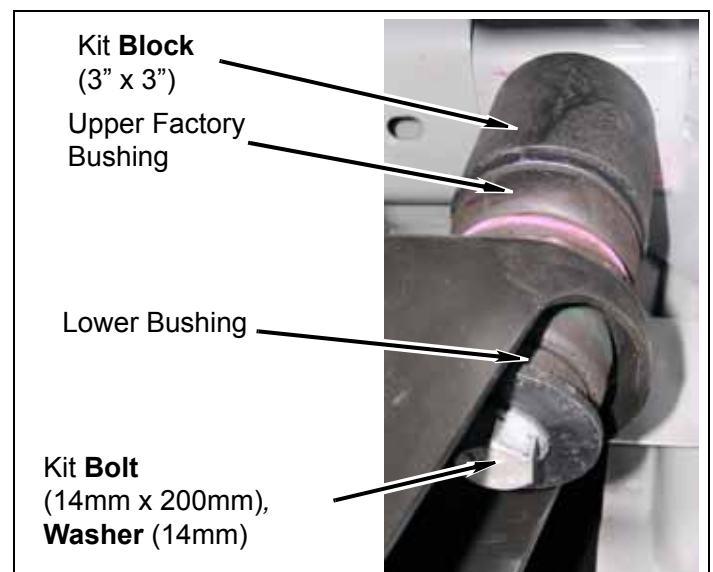

Bed

1. Lift bed

- a. Loosen, but **DO NOT** remove, bed mounting bolts on driver side (three bolts on vehicles with short bed; four bolts on vehicles with long bed).

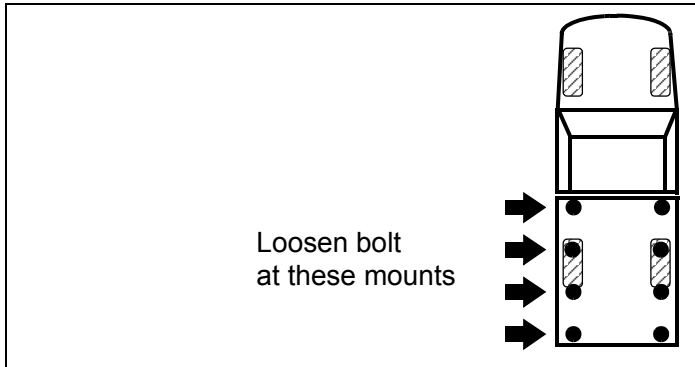

2. Remove a bolt from each passenger side bed mount.

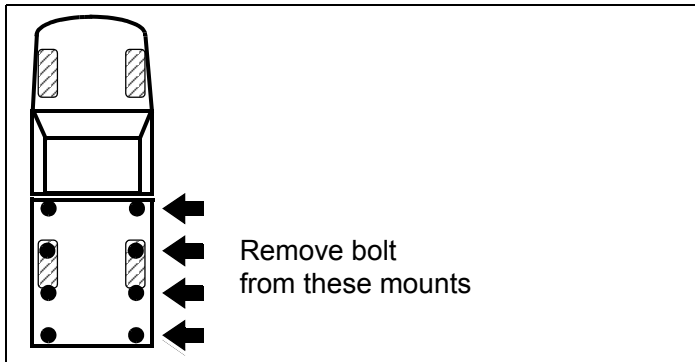

- b. Install kit **blocks** (3" x 3") on each frame mount.

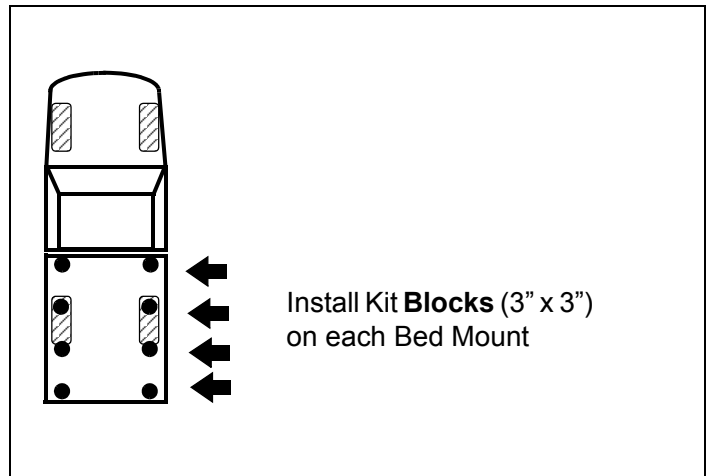

- c. Lower bed onto kit **blocks**.

- d. At each bed mount, install a kit **bolt** (12mm x 140mm). **DO NOT** tighten.

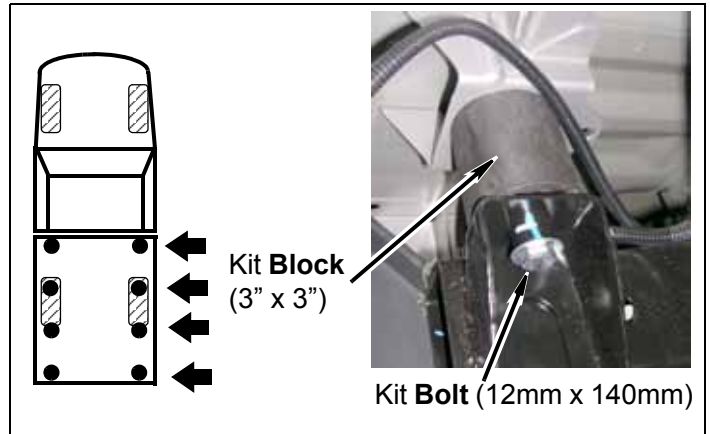

⚠ WARNING

Use extreme caution when lifting the bed from the frame. To prevent serious personal injury, ensure the lifting device is securely placed. Keep your hands out from between the bed and frame.

⚠ CAUTION

To prevent damage to the vehicle while lifting the bed, continually check hoses, wires, brake lines, etc. to ensure everything is flexing properly and not binding. Ensure clearance between bed and cab is maintained.

3. Bed passenger side.

- a. Using a hydraulic jack and a wooden block, slowly lift passenger side of bed a little more than 3".

⚠ NOTE

It may be necessary to lift the back of the bed slightly to allow the two rear bed mount bolts to be installed.

- e. Repeat previous steps on driver side of bed.
- f. Set bed-to-cab spacing according to previous measurement.
- g. Remove each kit **bolt** (12mm x 140mm), one at a time, and apply a few drops of Loctite® to threads. Install kit **bolt** (12mm x 140mm) and kit **washer** (7/16"). Tighten kit **bolt** to **55 ft. lbs.**

Rear of Vehicle

1. Spare Tire

- a. Mark and cut rear crossmember above existing hole as shown.

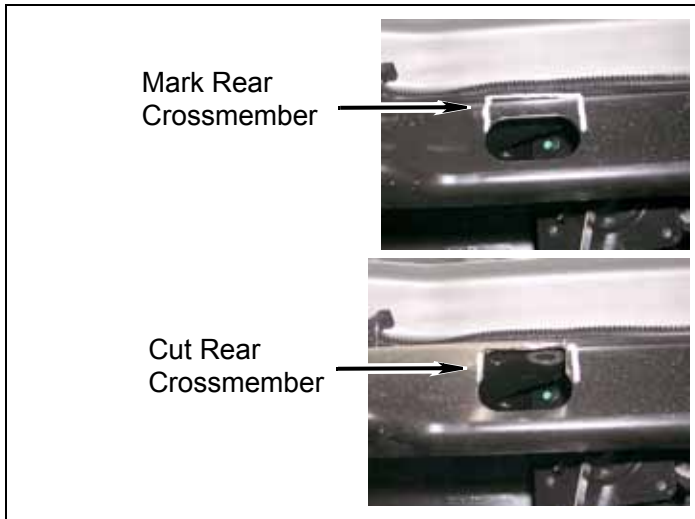

2. Rear Bumper

⚠ WARNING

The following procedure is intended only to enhance the appearance of the vehicle. The rear bumper will no longer be rated for towing of any kind. Towing with the rear bumper after it has been lifted can result in death, serious personal injury, or damage to the vehicle. Towing after the bumper has been lifted should be accomplished using a rated Class III receiver type hitch.

- a. **Passenger Side:** Remove cover plate from top of rear bumper by squeezing four plastic tabs.

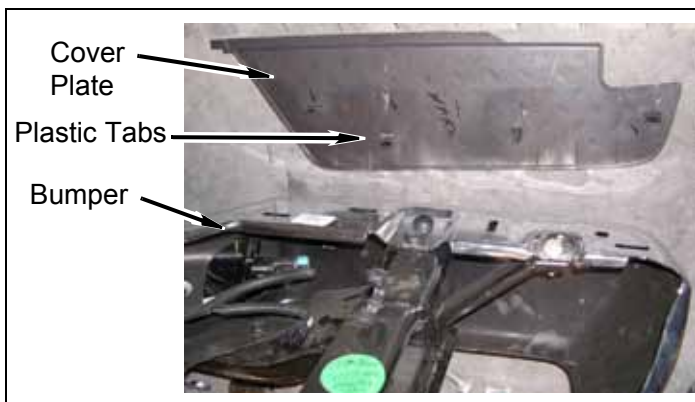

- b. Remove two torx bolts and loosen bolt holding brace to bumper. Remove three bolts and rear bumper bracket from bumper.

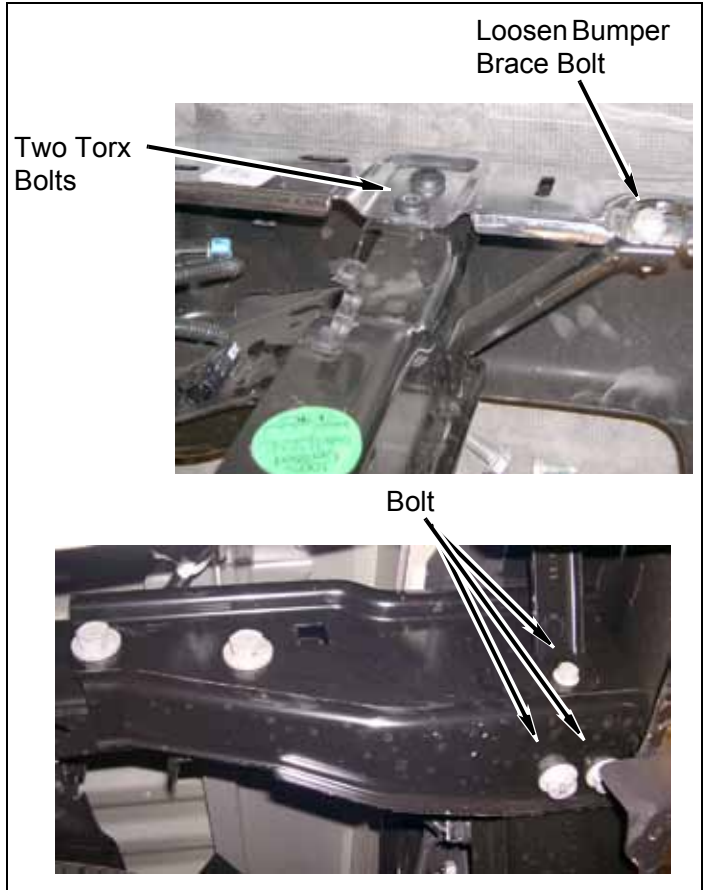

- c. Position two kit **rear bumper spacers** on frame.
- d. Position each **rear bumper bracket** over lapping tab and secure loosely with **bolt, 3/8" x 1" & hardware**. Secure to vehicle using OE torx bolts removed.

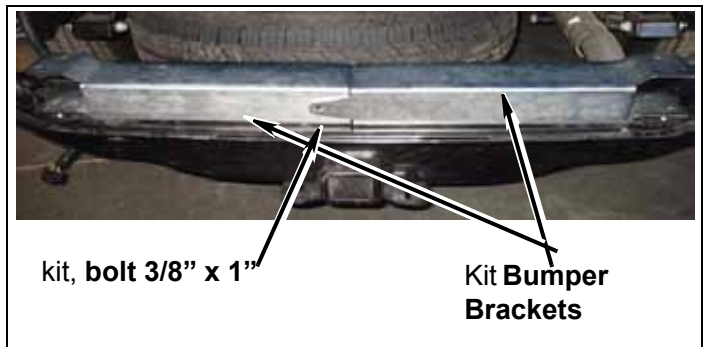

⚠ CAUTION

Use caution when installing the bumper making sure not to scratch the truck bed.

e. Install bumper using **bolts, 3/8" x 1" & hardware** through center brackets. Use four **bolts, 10mm x 100mm** through outer spacers.

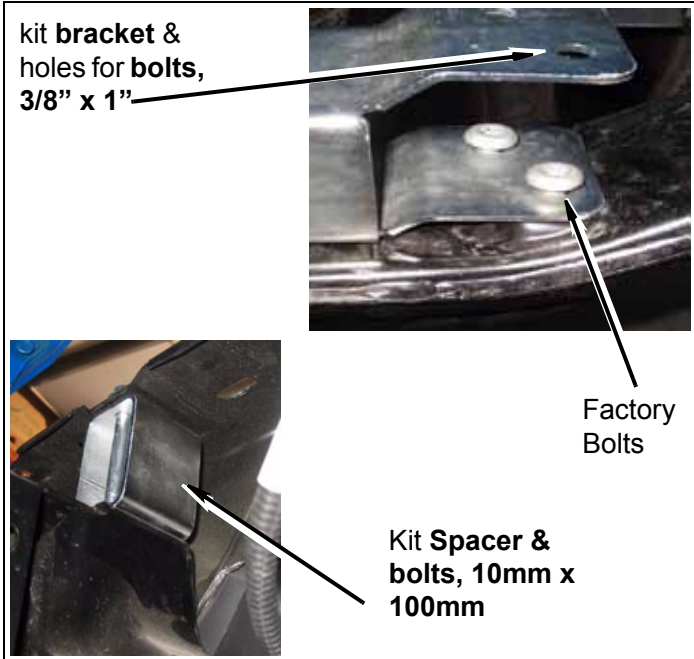

f. Mark bumper on both sides as shown to trim for clearance and trim.

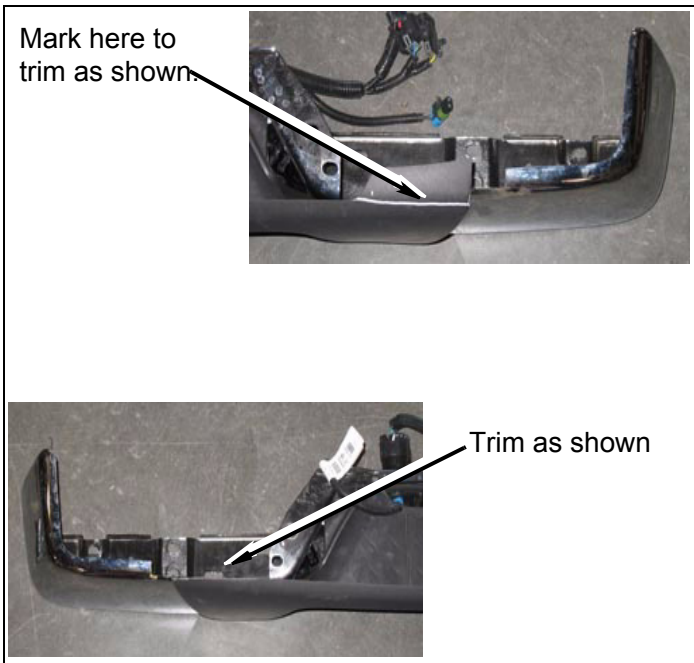

g. Align bumper to bed clearance and tighten all mounting bolts.

h. Install cover plates on top of rear bumper.

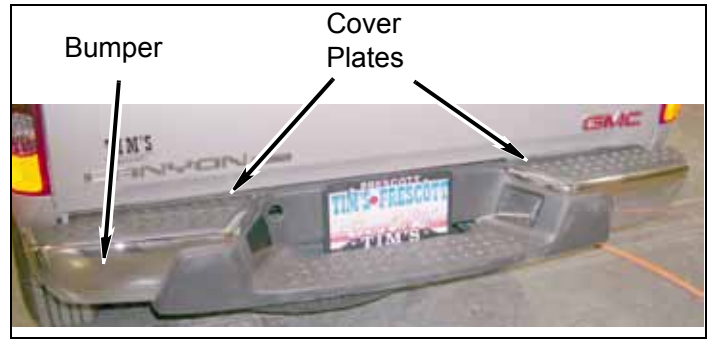

i. **Vehicles with hitch:** Remove two plastic pads from frame above rear tires.

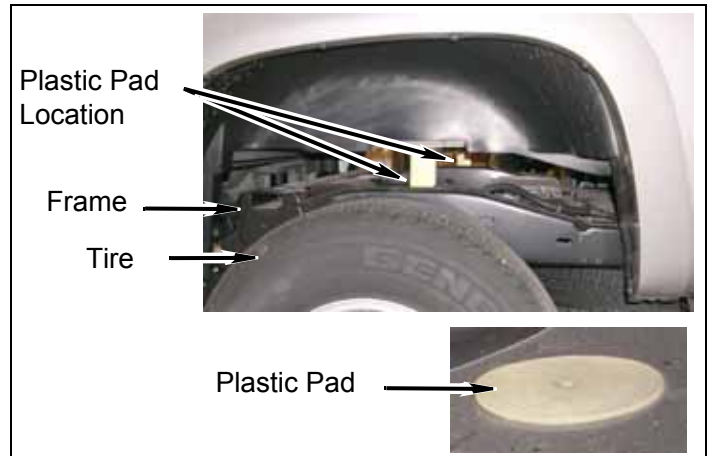

j. Install two plastic pads, removed from bed mounting locations, into kit **bumper to hitch bracket**. Holes may require enlarging.

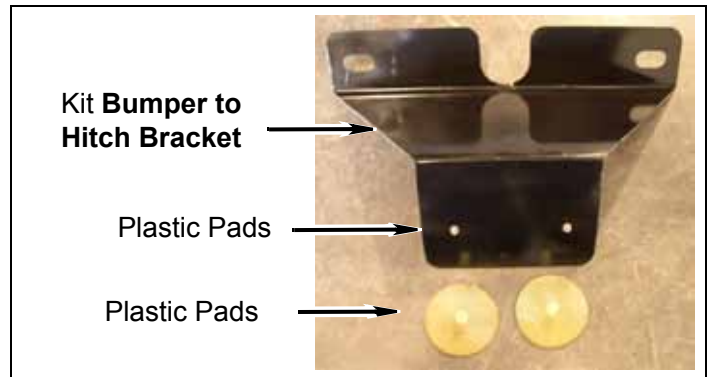

k. Install two kit **U-nuts** to underside of bumper as shown.

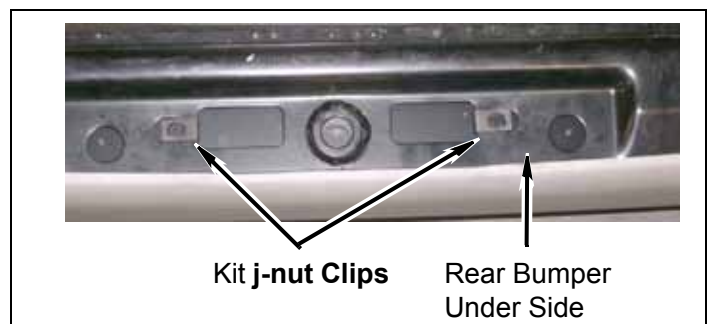

- l. Install two kit **bolts** (5/16" x 1"), and kit **bumper to hitch bracket** on vehicle.



- m. Install trailer tow wire harness clip on bumper.

3. Fuel Filler

⚠ WARNING

Use extreme caution when working near the fuel lines and the fuel tank. Clean up spilled fuel immediately. A spark could cause an explosion or fire resulting in serious personal injury and property damage.

- a. Remove bolt and ground strap from frame.

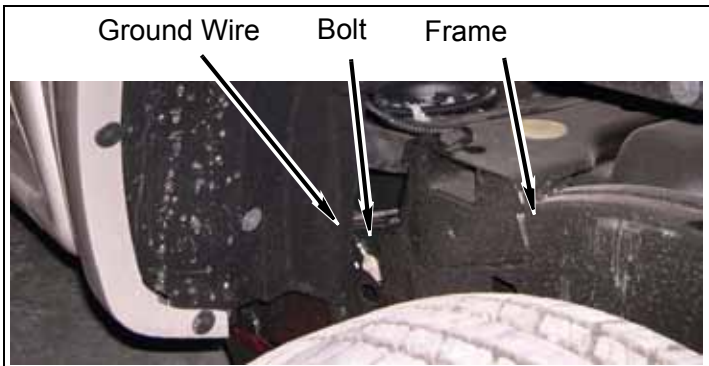

- b. Remove hose clamp, fuel clip and fuel filler from hoses and vehicle.

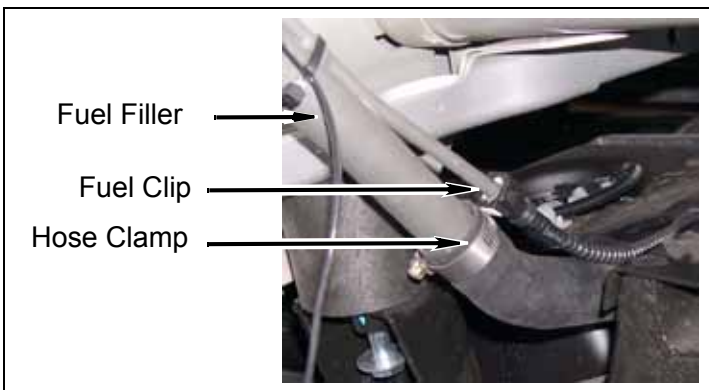

- c. Cut two fuel filler metal lines as shown.

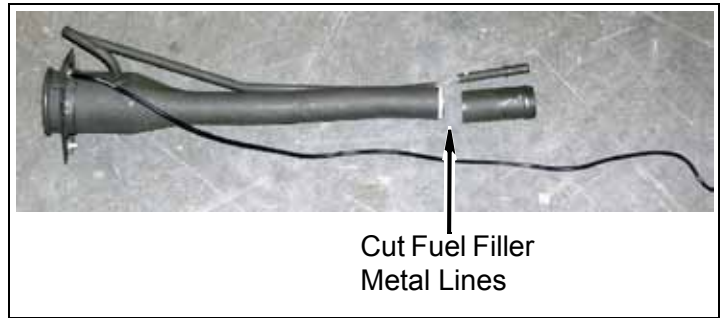

- d. Install two kit **hose clamps # 20**, and kit **hose** (1" x 4") on large filler line. Install two kit **hose clamps # 6** and kit **hose** (1/4" x 4") on smaller fuel line.

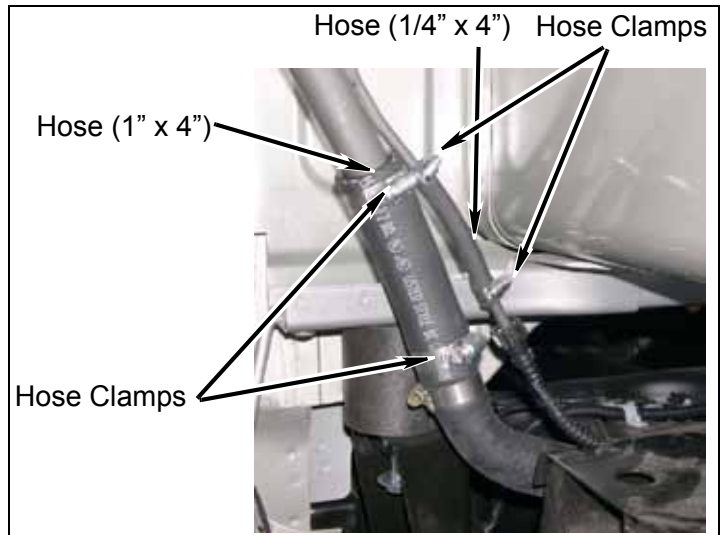

- e. Install a kit **bracket, ground strap** on frame with bolt. Install ground strap on kit **bracket, ground strap** with a kit **washer** (1/4") and kit **nut, nylock** (1/4").

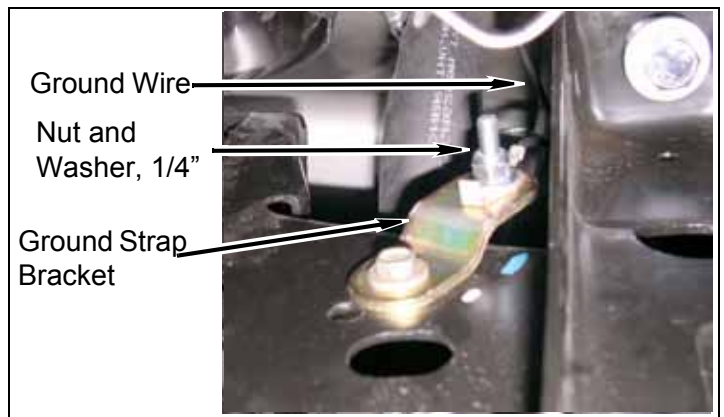

Inside Cab

1. Manual Transmission: Shift Lever

- a. Unscrew shift knob from shift lever.
- b. Release clips and remove shift boot from shift lever.
- c. Remove center console from floor.
- d. Remove bolts and shift cover from floor.
- e. Remove four bolts holding shift lever to transmission.

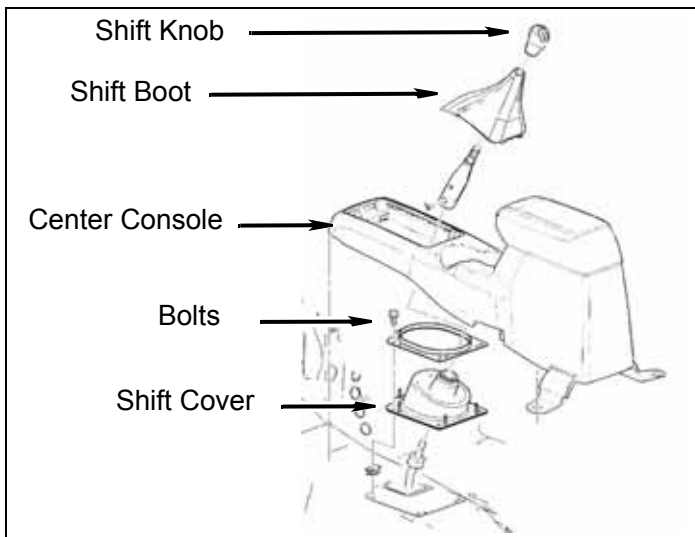

- f. Slide grommet, inner boot, and mounting plate off shift lever.
- g. Remove plastic retainer from ball socket on shifter.

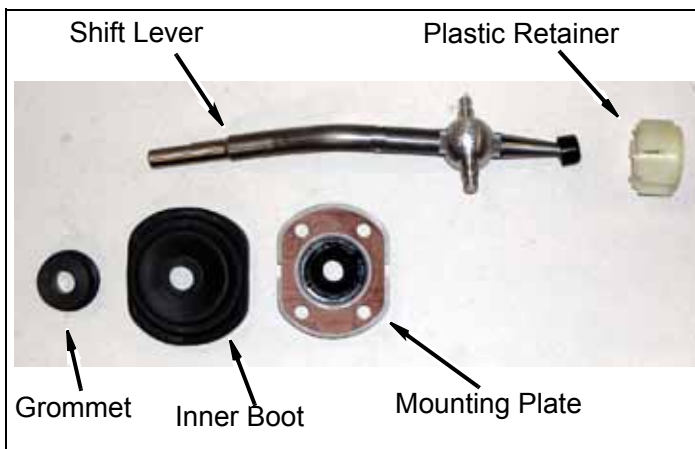

- h. Scribe a line along the side of the shift lever (below the lowest bend) as shown. Cut the lever into two pieces through the line and deburr as necessary.

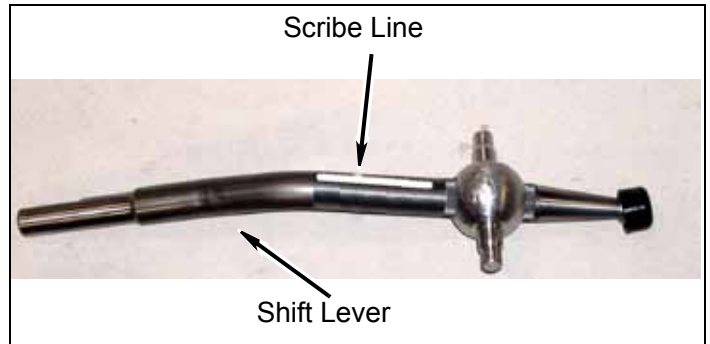

- i. Scribe a line along length of kit **shift extension**.
- j. Weld both halves of shift lever to kit **shift extension** making sure to align the scribed lines of all pieces.
- k. Assemble the shift lever in reverse order of disassembly.

Underside of Vehicle

1. Ground strap
 - a. Install bolt and ground strap on cab.



Engine Compartment

1. Steering shaft.

⚠ WARNING

Verify the steering extension is securely installed as specified in the instructions. Failure to do so may cause steering malfunction, resulting in property damage or serious personal injury.

- a. Remove bolt and steering intermediate shaft from rack and pinion and vehicle.

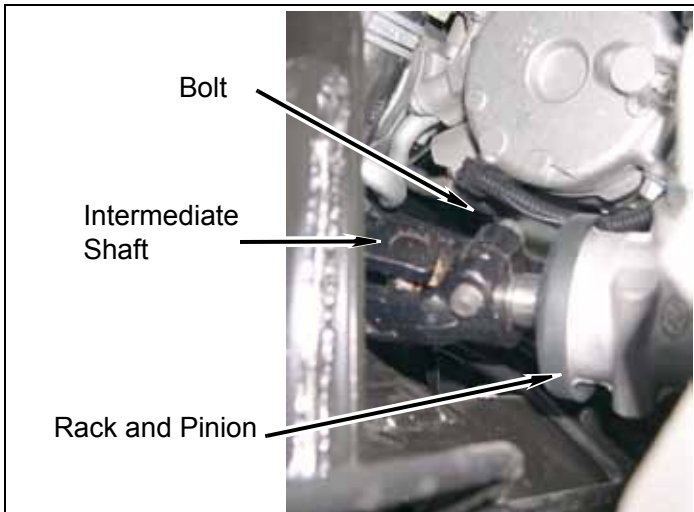

- b. Install female end of kit **steering extension** on male end of intermediate shaft. Place a few drops of Loctite on threads of kit **bolt**. Tighten kit **bolt** (3/8" x 1 1/4" Allen head) to 30 ft-lbs.

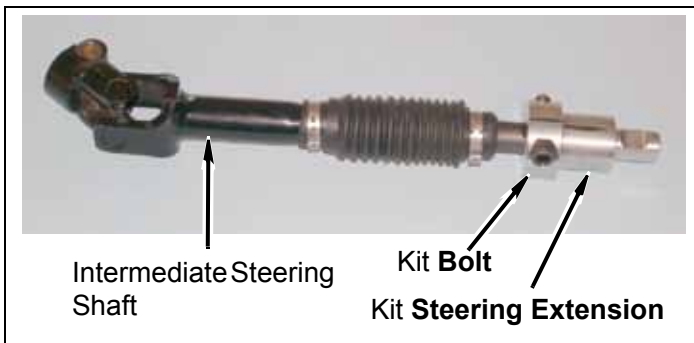

- c. Install kit **steering extension** and intermediate shaft making sure kit **steering extension** is installed on the upper steering shaft. Align marks on steering intermediate shaft and upper shaft.

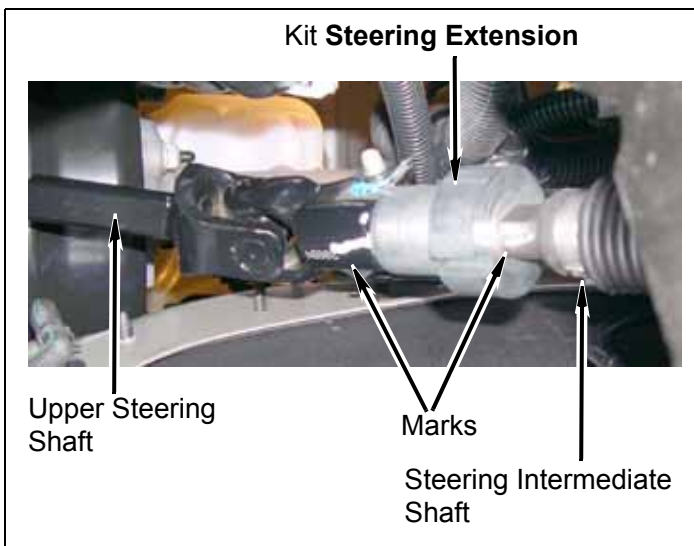

- d. Install lower intermediate shaft on the rack and pinion.

- e. Apply a few drops of Loctite® to factory bolt and tighten bolts to 33 lb.-ft.

2. Radiator

- a. **Passenger Side:** Trim two sections from lower radiator support as shown.

Passenger Side Lower Support - from Top

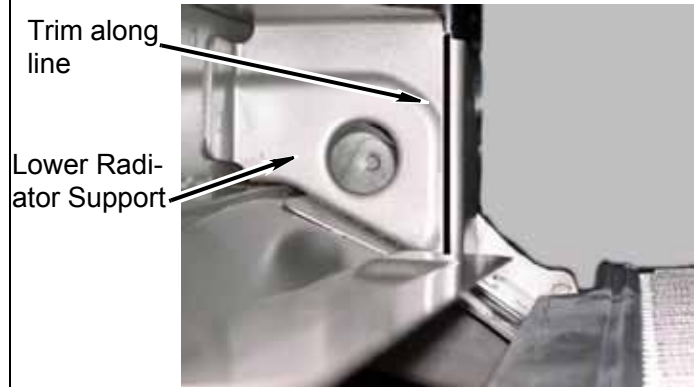

Modified Lower Radiator Support



Passenger Side Lower Support - from Bottom

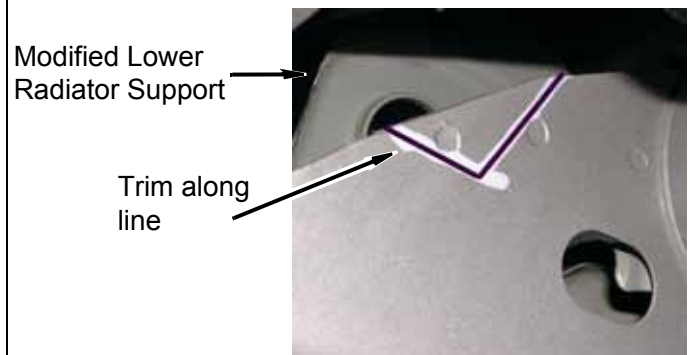

- b. **Driver Side:** Trim lower radiator support bracket as shown.

Driver Side Lower Support - from Top

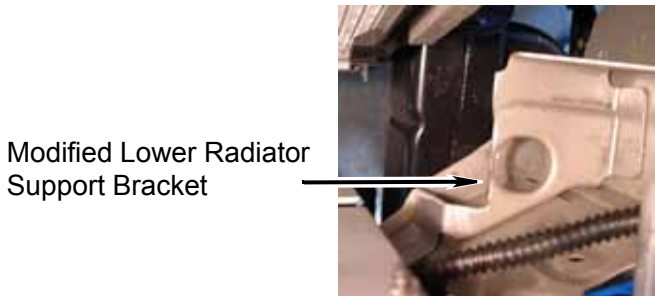
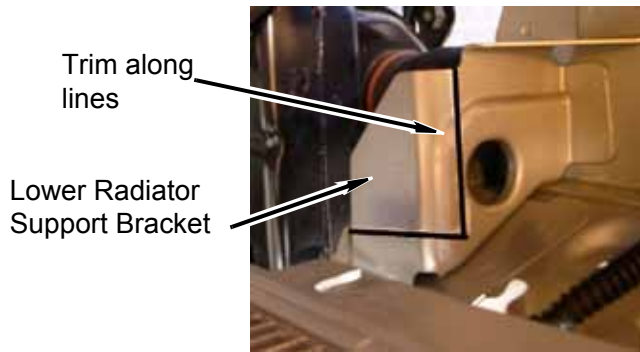

Driver Side Lower Support - from Bottom

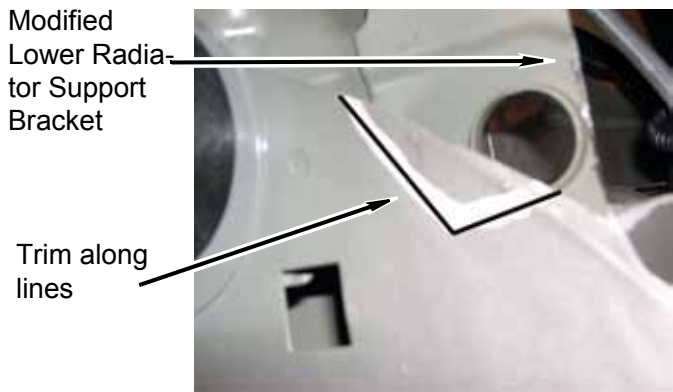

- c. Install two kit **U-nuts** on kit **brackets**, radiator drop down.

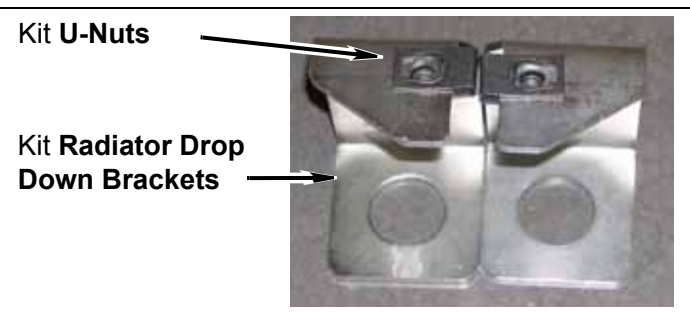

⚠ CAUTION

When performing the radiator installation, make sure the studs on the two radiator brackets, installed in the next step, do not puncture the condenser while maneuvering the radiator into position.

- d. Place a few drops of Loctite on threads of kit **screws**. Install two kit **screws** and kit **bracket**, **3" radiator drop down** as shown.

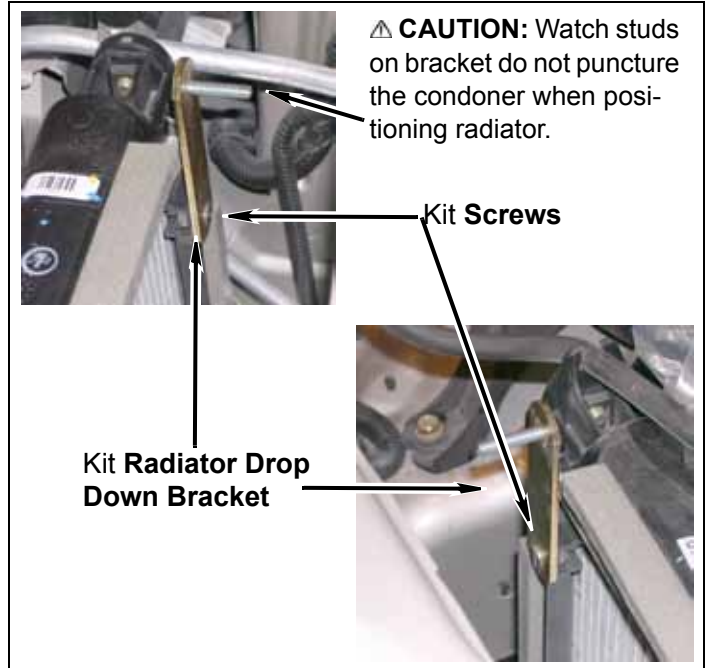

- e. Place kit **bracket**, **lower radiator** on lower radiator mount grommets.

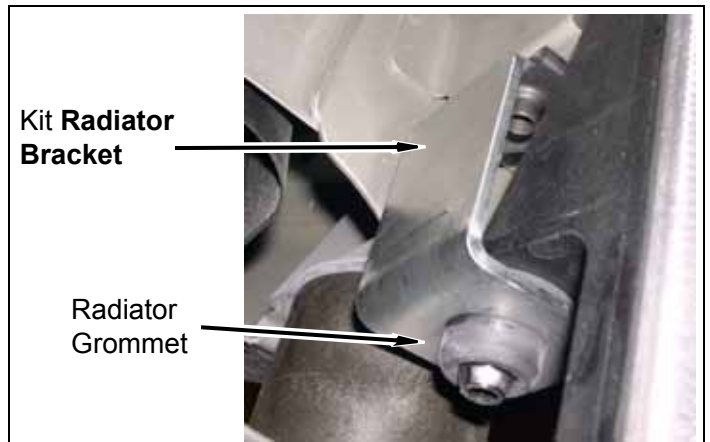

- f. **Passenger Side:** Install kit **brackets, radiator drop down** with kit **washers** (1/2" thick), kit **washer** (5/16"), and kit **bolt** (5/16" x 1 1/4") below radiator support bracket making sure kit **bracket** is pushed forward as far as possible.

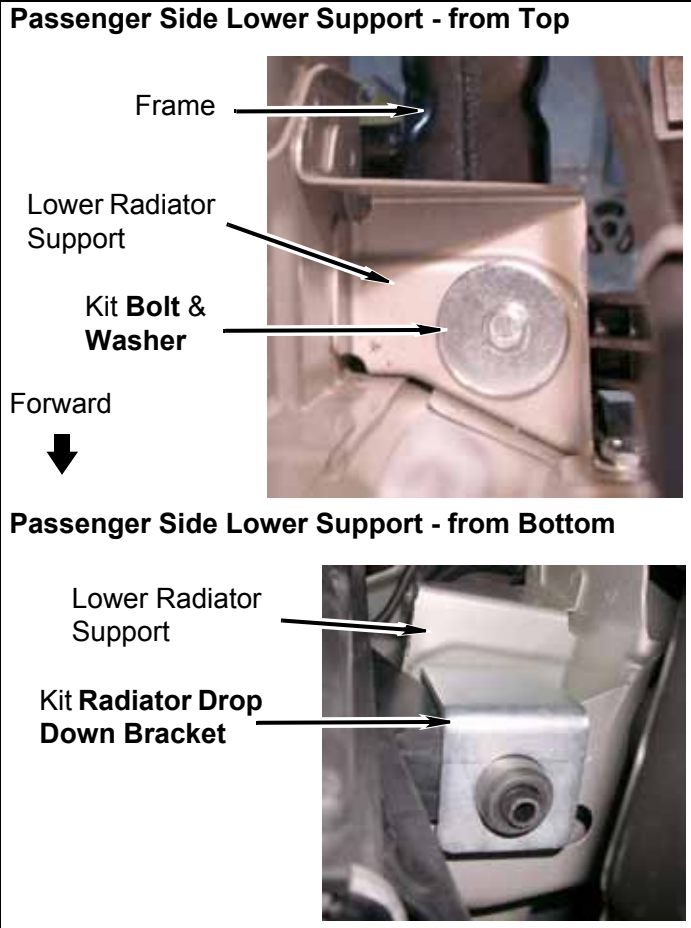

- g. **Driver Side:** Install kit **brackets, radiator drop down** with kit **washers** (1/2" thick), kit **washer** (5/16"), and kit **bolt** (5/16" x 1 1/4") below radiator support bracket making sure kit **bracket** is pushed forward as far as possible.

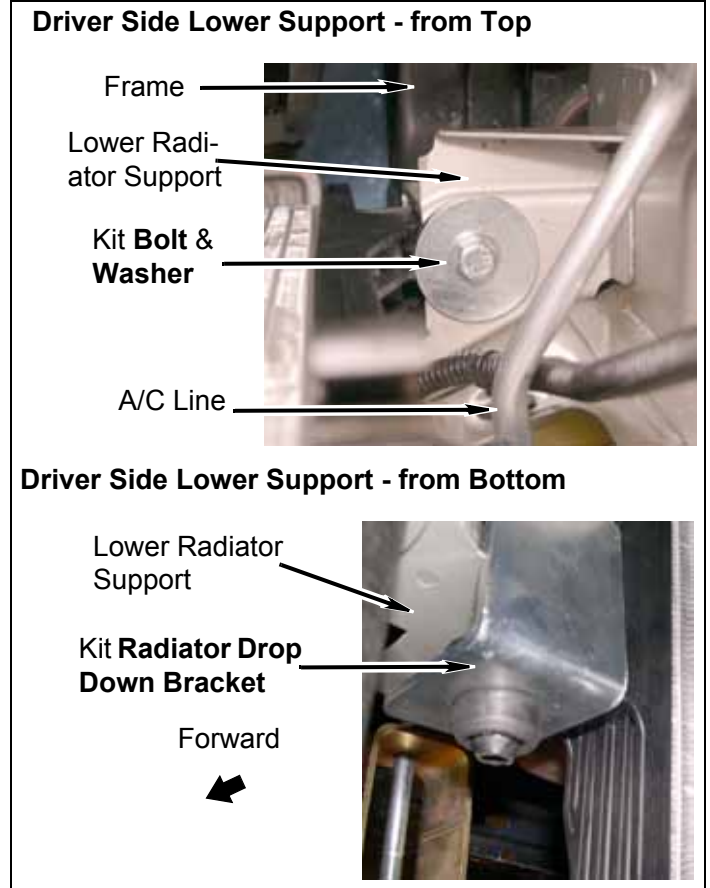

- h. Remove kit **zip tie** from condenser and body.
- i. Install condenser on two kit **drop down bracket studs** (3") with two kit **washers** (1/4") and two kit **nylock nuts** (1/4"). **DO NOT TIGHTEN.**

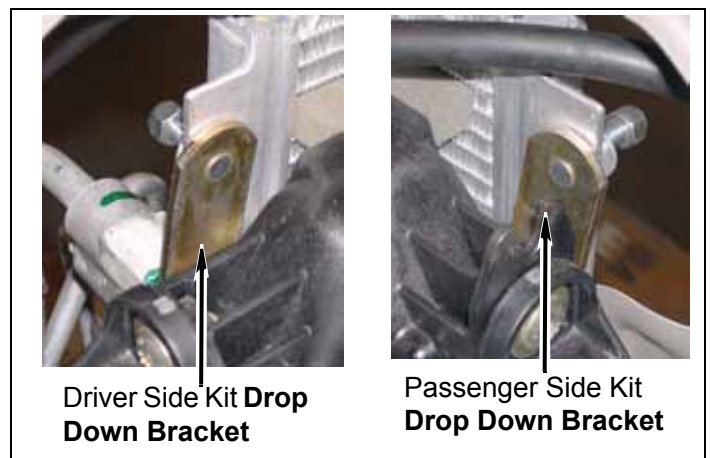

⚠ WARNING

Failure to use a block of wood behind the condenser will cause damage to the radiator. Performance Automotive Group will not be responsible for radiator damage.

- j. Mark and drill two 1/4" holes in condenser and body as shown using a block of wood to prevent drill from puncturing lines.

Driver Side

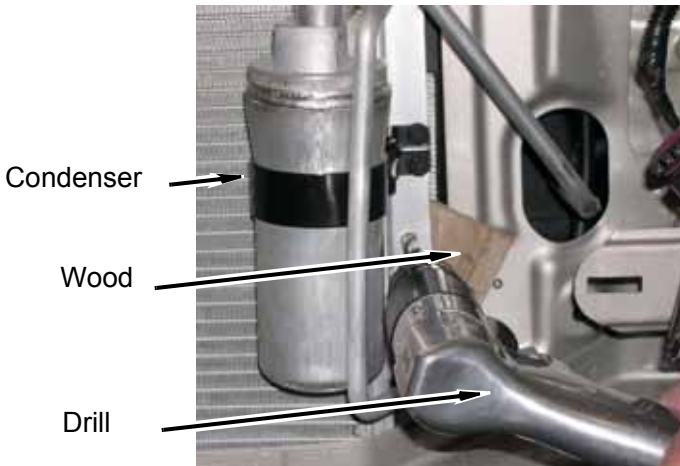
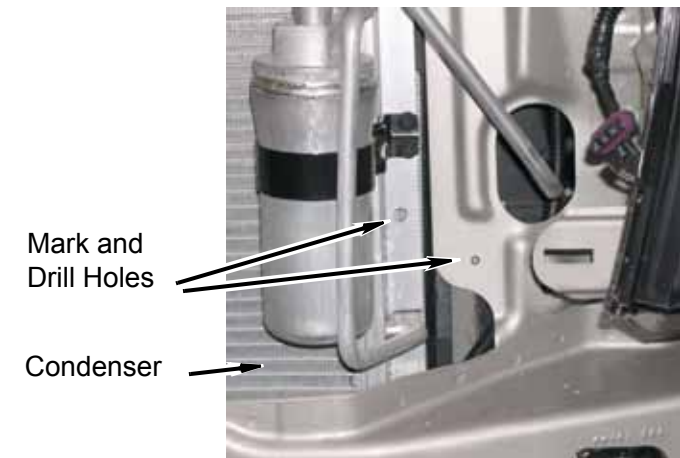

Passenger Side

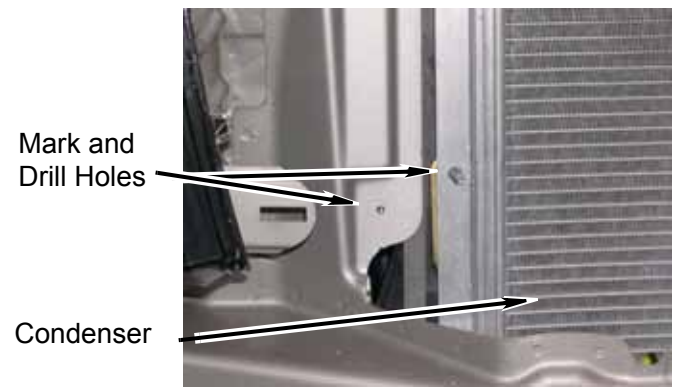

- k. Install studded end of two kit **drop down brackets** (2") on condenser with two kit **washers** (1/4") and two kit **nuts** (1/4").
- l. Install kit **drop down brackets** (2"), and condenser to body with two kit **bolts** (1/4" x 1"), four kit **washers** (1/4"), and two kit **nuts** (1/4").



Kit Bolt, Washers, and Nut Kit Drop Down Bracket Kit Washer and Nut

- m. Tighten kit **nuts** (1/4") on kit **radiator drop down brackets** (3").
- n. Install kit **upper radiator bracket** on core support and radiator with bolt.



Bolt Kit Upper Radiator Bracket

3. Fan Shroud

- a. Place lower fan shroud and ring shroud on radiator.

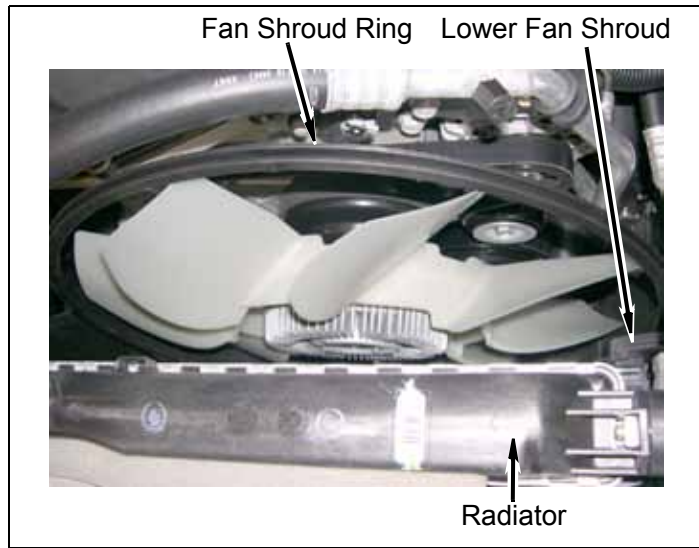

- b. Install fan clutch and fan on vehicle. Install two pulley bolts.

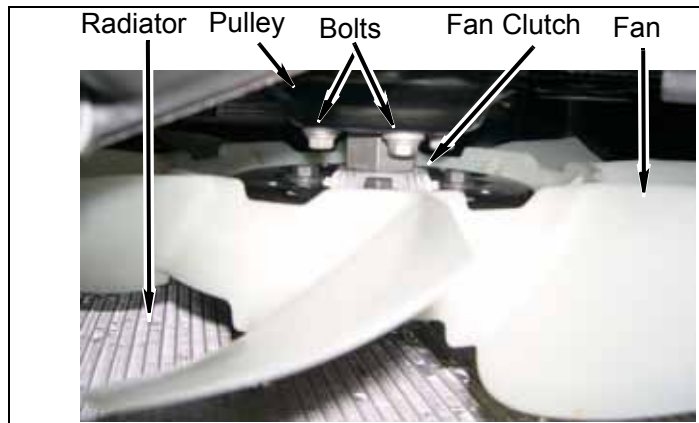

- c. Install upper fan shroud to lower fan shroud with six clips.

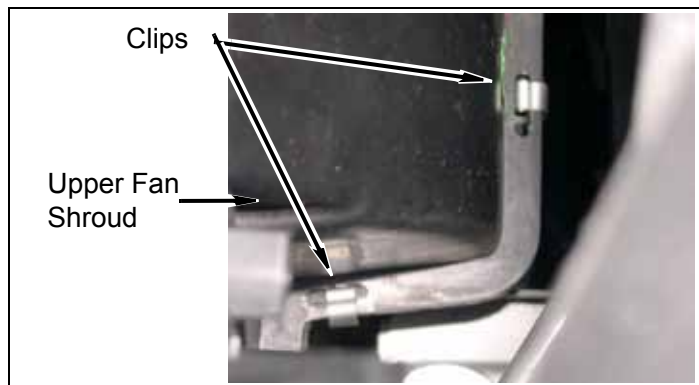

- d. Install upper radiator hose to radiator

- e. Place over flow hose on passenger side upper fan shroud clip.

- f. Place a/c line in passenger side fan shroud clip.

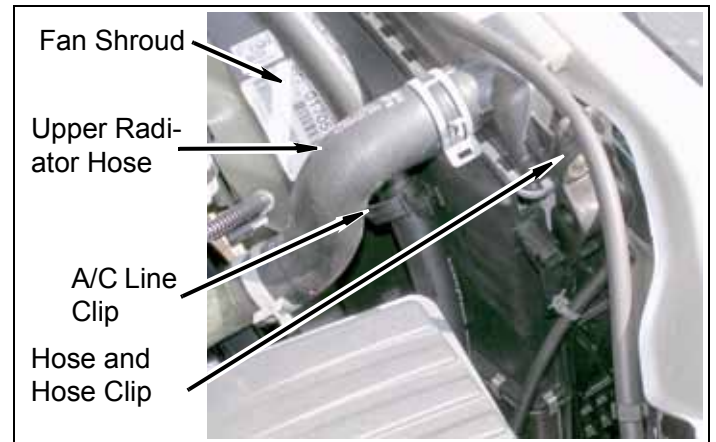

4. Air Box

- a. Remove two bolts from passenger side of engine mounted air intake box.

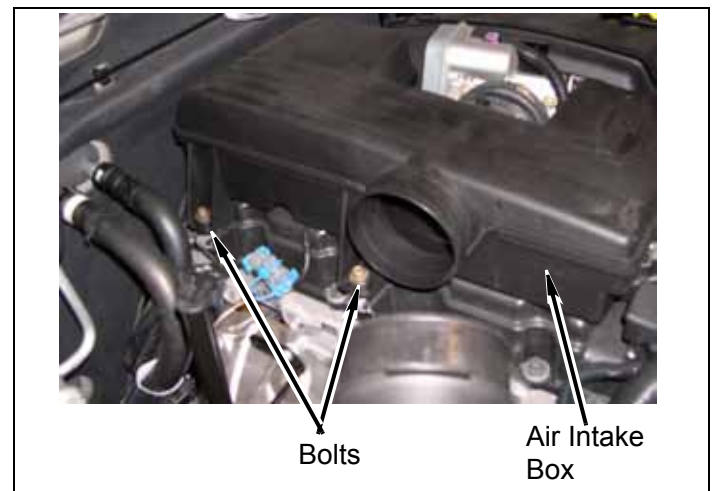

- b. Remove two u-nut clips from intake.

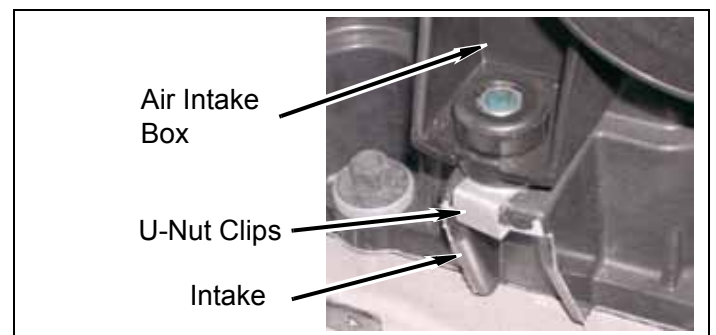

- c. Install two kit **spacers** (1" tube), two kit **bolts** (1/4" x 3"), four kit **washers** (1/4"), and two kit **nylock nuts** (1/4").

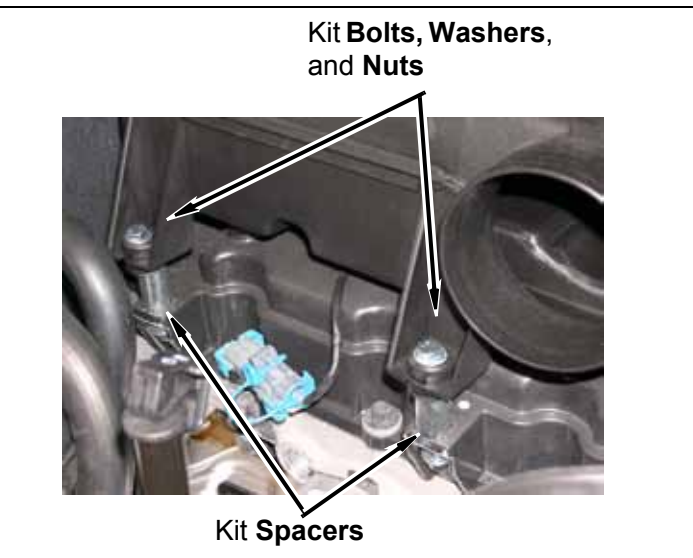

- d. Install intake hose to air box and engine mounted air intake box with two clamps.

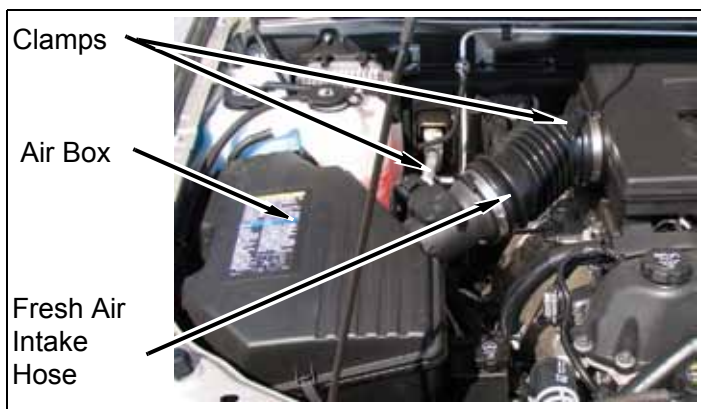

5. Cut air pump hose removed on page 4 of instructions and install **Spacer Tube, 1"od x 5" lg** to extend a total of 3". Secure tube with **hose clamps** provided and reinstall on vehicle.

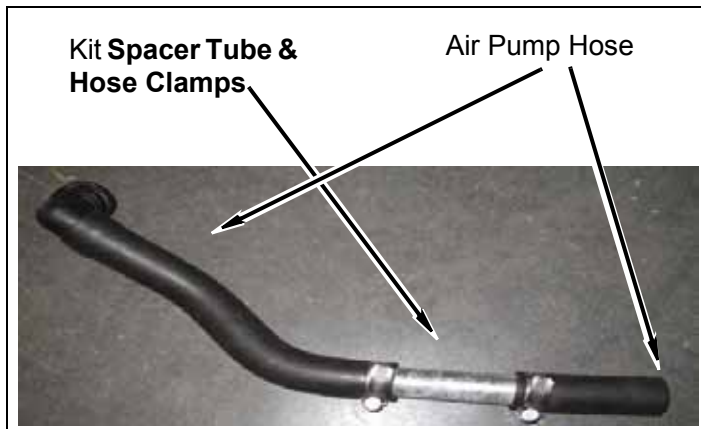

Front of Vehicle

1. Front Bumper

- a. Remove two outer push clips, eight air dam clips and lower air dam from lower fascia.

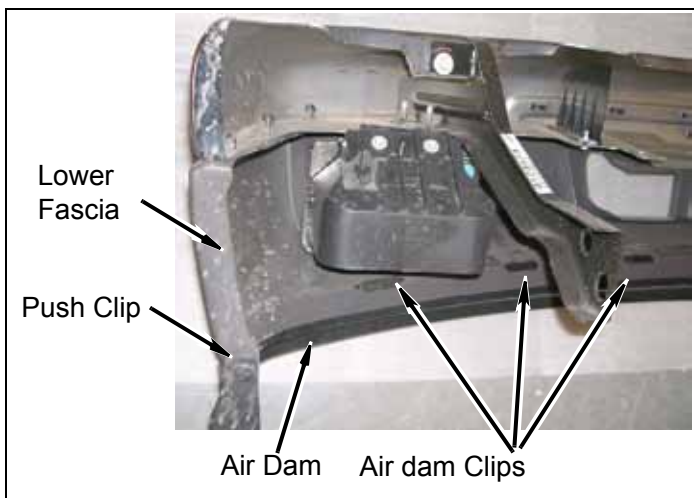

- b. Trim front bumper lower fascia, to clear frame horns, as shown.

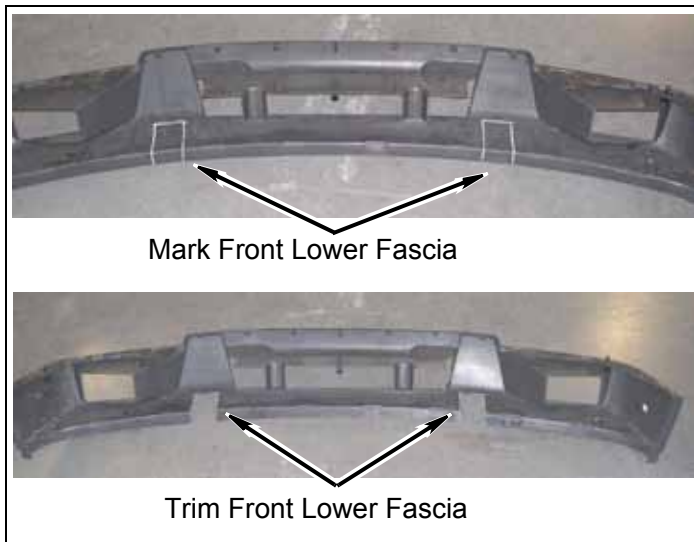

- c. Install four kit **mini blocks** (3" x 2"), bumper, four kit **washers** (5/16"), and **bolts** (10mm x 100mm) on front of vehicle. Place a few drops of Loctite on threads of kit **bolts**.

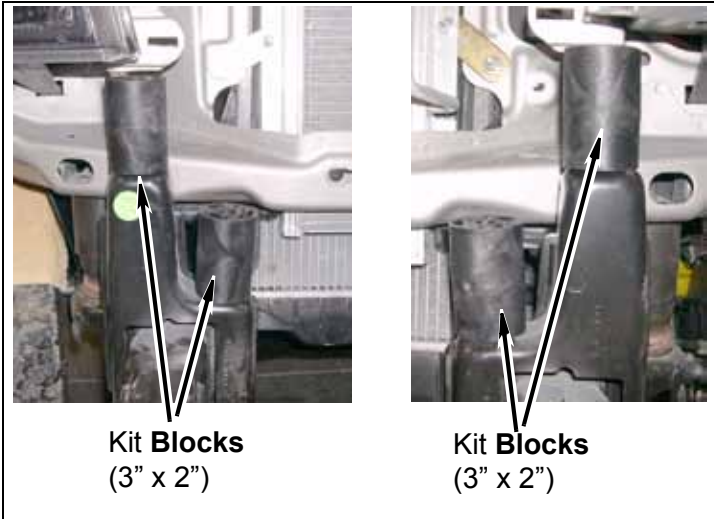

- d. Install kit **side bumper support brackets** with four bolts, four kit **bolts** (7/16" x 1 1/2"), eight kit **washers** (7/16"), and four kit **nylock nuts** (7/16") on bumper and frame. Place a few drops of Loctite on threads of bolts.

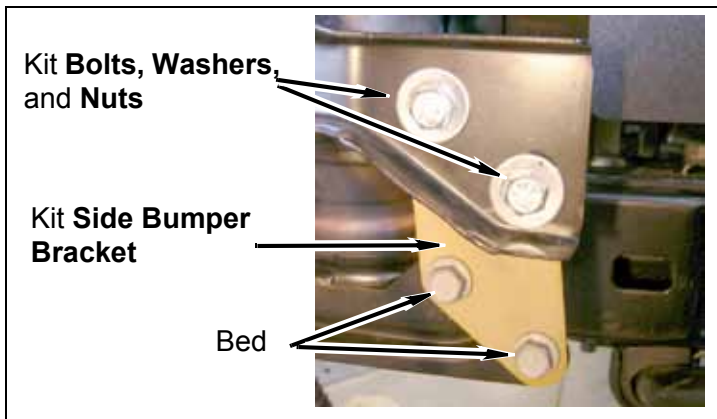

- e. Position air dam on lower front fascia and mark locations to be cut as shown.



- f. Install lower air dam on lower front fascia.

Bed Spacers

1. Install two (four on vehicles with standard cab or extra cab) kit **bolt** (5/16" self tapping), kit **washers** (5/16" USS) and kit **bed spacers** to frame. It may be necessary to remove the plastic pads from frame before installing kit **bed spacers**.

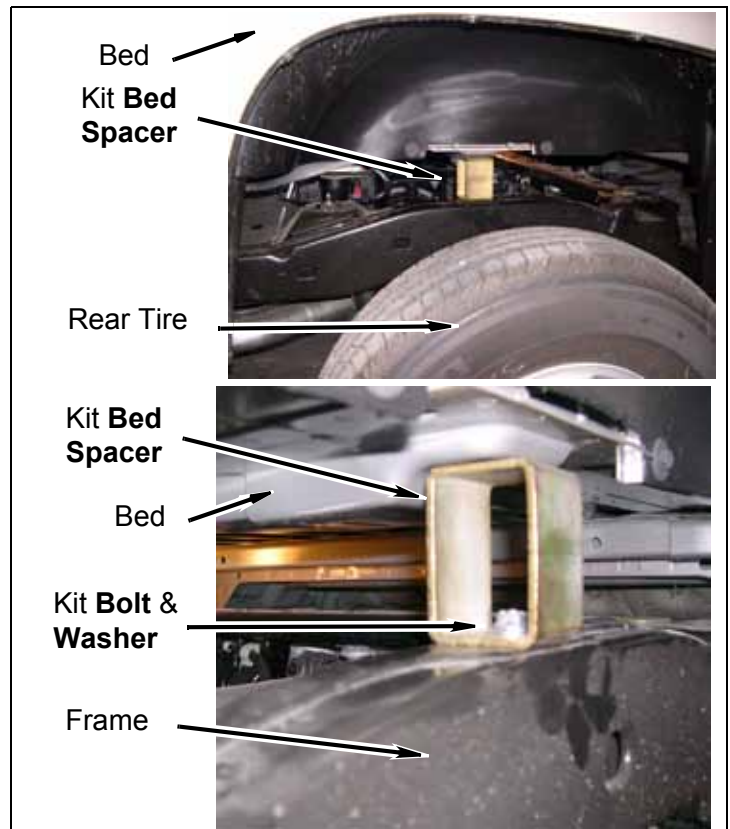

After Completing Installation

Engine Compartment

1. Install airbag fuse and fuse block cover.

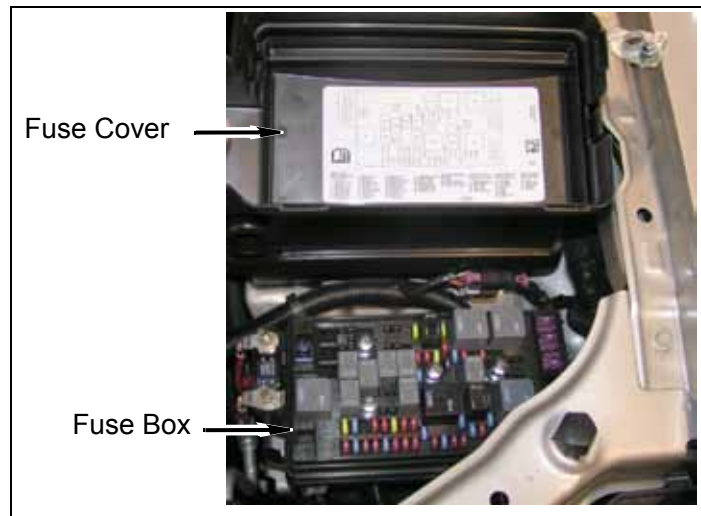

2. Battery cables.
 - a. Connect both battery cables. Connect positive cable first, then negative cable.

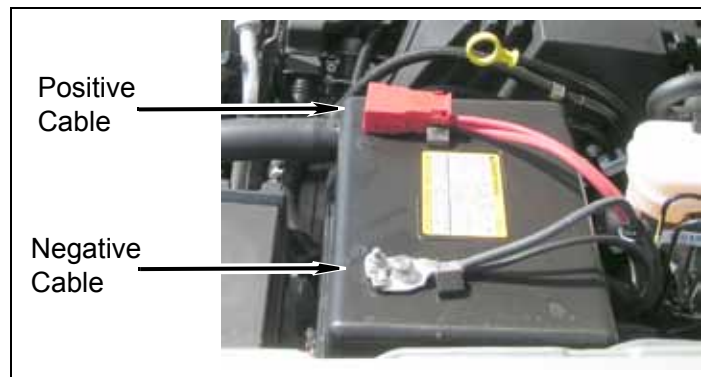

Final Installation Notes

1. Apply kit **label** (warning) to dashboard in plain sight of all vehicle occupants.
2. Check all fasteners to ensure they are tight.

3. Ensure all wires, hoses, cables, etc. are properly connected and there is ample slack.

⚠WARNING

If the engine cooling system is hot, the coolant will be **HOT** and **UNDER PRESSURE**. To prevent serious personal injury, wait until the cooling system is completely cool before removing the cap from the radiator.

4. Remove radiator cap and fill radiator with engine coolant.
5. Start engine and top off engine cooling system. Purge air from cooling system according to manufacturer's instructions.
6. Install radiator cap.

Dynamic Vehicle Check

1. Test-drive vehicle. Check steering in both directions to ensure that there is no binding. Check operation of clutch, brake system, and parking brake. Check operation of transmission and transfer case. Ensure there is full engagement in all gears and 4WD ranges. Check battery connections and electrical component operations.

⚠WARNING

Retorque all fasteners after 500 miles and after off road use. All body lift components should be visually inspected and fasteners retorqued during routine vehicle servicing.

⚠CAUTION

Performance Automotive Group does not recommend any particular wheel and tire combinations for use with its body lifts and cannot assume responsibility for the customer's choice of wheels and tires. Refer to your owner's manual for recommended tire sizes and warnings related to the use of oversized tires. Larger wheel and tire combinations increase stress and wear on steering and suspension components, which leads to increased maintenance and higher risk for component failure. Larger wheel and tire combinations also alter speedometer calibration, braking effectiveness, center of gravity, and handling characteristics. Consult an experienced local off road shop to find what wheel and tire combinations work best with your vehicle.

△NOTE

All warranty information, instruction sheets, and other documents regarding the installation of this product must be retained by the vehicle owner. Information contained in the instructions and on the warranty card will be required for any warranty claims. The vehicle owner needs to understand the modifications made to the vehicle and how they affect vehicle handling and performance. Failure to provide the customer with this information can result in damage to the vehicle and severe personal injury.

Rev. 01, Copyright 12/04 Performance Automotive Group

Qty. Description**Kit 10223**

- 4 **Block**, 3" x 2" Mini Block
- 6 **Block**, 3" x 3" Lift
- 8 **Block**, 3" x 3" Lift w/ 5/8" Hole
- 4 **Block**, Crush 3" x 2"
- 2 **Bolt**, 1/4" x 1"
- 2 **Bolt**, 1/4" x 3"
- 8 **Bolt**, 10mm x 100mm
- 6 **Bolt**, 12mm x 1.75 x 140mm
- 8 **Bolt**, 14mm x 2.00 x 200mm
- 4 **Bolt**, 5/16" Self Tapping
- 2 **Bolt**, 5/16" x 1 1/4"
- 2 **Bolt**, 5/16" x 1"
- 4 **Bolt**, 7/16" x 1 1/2"
- 6 **Bolt**, 3/8" x 1"
- 2 **Bracket**, Bumper Support
- 1 **Bracket**, Lower Radiator Support Left
- 1 **Bracket**, Lower Radiator Support Right
- 2 **Bracket**, Radiator 2"
- 2 **Bracket**, Radiator 3"
- 1 **Bracket**, Radiator Offset 2" w/stud
- 1 **Bracket**, Rear Bumper Center Left
- 1 **Bracket**, Rear Bumper Center Right
- 2 **Spacer**, Rear Bumper Outer
- 1 **Bracket**, Upper Radiator Support
- 1 **Tube**, 1"od x 5" lg Air Pomp Line
- 4 **Clamp**, Hose # 20
- 2 **Clamp**, Hose # 6
- 1 **Extension**, Shift
- 1 **Extension**, Steering
- 1 **Hose**, Fuel Filler 1" x 4"
- 1 **Hose**, Fuel Filler 1/4" x 4"
- 9 **Nut**, 1/4" Nylock
- 4 **Nut**, 7/16" Nylock
- 2 **Screw**, 6mm x 2.0 Tapped
- 2 **Spacer**, 1" x .671OD x .5ID
- 4 **Tie**, Zip

- 4 **U-Nut** 5/16"
- 2 **Washer**, 1/2" thick
- 18 **Washer**, 1/4"
- 8 **Washer**, 14mm
- 8 **Washer**, 5/16" USS
- 14 **Washer**, 7/16"
- 6 **Washer**, 3/8"

Steering Extension**△ NOTE**

Depending on the vehicle configuration (automatic or manual transmission, 2WD or 4WD, cab length, bed length, etc.), some parts may not be used.

Accessories (Available After 3/1/05)**The following accessories are also available:**

Kit # 83300: Pre-Runner Front Bumper

Kit # 83400: Pre-Runner Rear Bumper

Kit # 84300: Side Bars

Kit # 86300: Pre-Runner Spare Tire Carrier

