



FORD BRONCO BODY LIFT KIT INSTALLATION INSTRUCTIONS

1992-1996 2" KIT #842

1992-1996 3" KIT #843

⚠ WARNING

Installation of a Performance Automotive Group body lift kit will change the vehicle's center of gravity and handling characteristics both on- and off-road. You must drive the vehicle safely! Extreme care must be taken to prevent vehicle rollover or loss of control, which could result in serious injury or death. Avoid sudden sharp turns or abrupt maneuvers and always make sure all vehicle occupants have their seat belts fastened.

⚠ WARNING

Before you install this kit, read and understand all instructions, warnings, cautions, and notes in this instruction sheet and in the vehicle owner's manual.

⚠ CAUTION

Proper installation of this kit requires knowledge of the factory recommended procedures for removal and installation of original equipment components. We recommend that the factory shop manual and any special tools needed to service your vehicle be on hand during the installation. Installation of this kit without proper knowledge of the factory recommended procedures may affect the performance of these components and the safety of the vehicle. We strongly recommend that a certified mechanic familiar with the installation of similar components install this kit.

⚠ WARNING

This kit should only be installed on a vehicle that is in good working condition. Before you install the kit, thoroughly inspect the vehicle for corrosion or deformation of the sheet metal around the factory body mounts. If the vehicle is suspected to have been in a collision or misused, do not install this kit. Off-road use of your vehicle with this kit installed may increase the stress applied to the factory body mounts. We do not recommend that any vehicle with a body lift kit installed be involved in any extreme off-road maneuvers such as jumping. Failure to observe this warning may result in serious personal injury and/or severe damage to your vehicle.

⚠ WARNING

Many states and municipalities have laws restricting bumper heights and vehicle lifts. Consult state and local laws to determine if the changes you intend to make to the vehicle comply with the law. Before combining a body lift with a suspension lift, consult an installation professional to see how this will affect the vehicle.

⚠ WARNING

The installation of larger tires may reduce the effectiveness of the Braking System.

⚠ WARNING

Always wear eye protection when operating power tools.

⚠ WARNING

Before you install this kit, block the vehicle tires to prevent the vehicle from rolling.

⚠ WARNING

Accidental deployment of the air bag can result in serious personal injury or death. To avoid accidental deployment during installation of the kit, the Supplemental Restraint System (SRS, or airbag) must remain deactivated. Do not allow anyone near the airbag during installation. Refer to the factory service manual or owner's manual for the recommended procedure to disable the SRS. After you install the kit, reactivate the SRS before driving the vehicle.

⚠ NOTE

Performance Automotive Group recommends using the Loctite® supplied in the kit on the threads of all kit nuts and bolts unless specified otherwise in these instructions.

Before Starting Installation

⚠ NOTE
This kit does not fit vehicles with 6-cylinder engine. The lower radiator hose can make contact with the belt pulley resulting in possible damage to the engine.

⚠ NOTE
This kit does not include rear bumper brackets and they are NOT available from Performance Automotive Group.

⚠ NOTE
Kit parts are prefaced by the word kit and appear in **bold** print.

1. Carefully read all warnings and instructions completely before beginning.
2. Verify all parts have been received in this kit by checking parts list at end of this document.

⚠ NOTE
If parts are missing from kit, please be prepared to provide the following information:
1. **Name** of purchase location
2. **Bar Code** on side of box
3. **Date** above bar code
4. **Date** inside box cover
5. **Inspector #** from inside box cover

3. **Only install this kit on the vehicle for which it is specified.** If anytime during the installation you encounter something different from what is outlined in the instructions, call technical support at (928) 636-7080.
4. Special tools needed:
 - a. Die grinder or similar tool capable of cutting metal.
5. Park vehicle on a clean, dry, flat, level surface and block tires so vehicle cannot roll in either direction.

Battery cables

1. Disconnect both battery cables. Disconnect negative cable first, then positive cable.

Airbag fuse

1. If vehicle is equipped with an air bag, remove airbag fuse. Fuse box is located on lower dash panel to right of steering column.

Measurements

1. Measure and record distance between front bumper and fenders.

Driver Side _____ Passenger Side _____

Prepare to Install Kit

Engine Compartment

1. Fan shroud
 - a. Remove two (2) bolts mounting fan shroud to top of radiator.
 - b. Pull shroud up and out of clips at bottom of radiator.
 - c. Remove fan shroud.
2. Smog canister
 - a. Remove two (2) nuts mounting smog canister to passenger side fender well.
 - b. Pull studs up and out of fender well.

NOTE:

Smog canister may need to be relocated closer to engine.

- c. Remove smog canister.

3. Steering shaft

⚠ WARNING

Some vehicles may be equipped with Supplemental Restraint System (SRS, or airbag). Accidental deployment of the airbag can result in serious personal injury or death. To avoid accidental deployment, the SRS must remain deactivated during installation of this kit. Do not allow anyone near the airbag during installation. Refer to the factory service manual or owner's manual for the recommended procedure to disable the SRS. After kit installation, the SRS must be reactivated before driving the vehicle.

⚠ CAUTION

If the following step is not performed, the airbag clock-spring could be damaged. Do not turn the steering wheel while the steering shaft is disconnected.

- a. Strap steering wheel to prevent accidental movement.
- b. Mark position of upper steering shaft with relation to steering coupler.

- c. Remove factory bolt securing main steering shaft to universal joint under dash.
- d. Slide steering shaft out of universal joint. Install male end of **kit steering extension** into universal joint.
- e. Apply **kit Loctite®** to threads, install, and tighten factory bolt into universal joint. Ensure factory bolt is through notch in **kit steering extension**. Tighten factory bolt to manufacturer's specification.

NOTE:

DO NOT INSTALL steering shaft into **kit steering extension** at this time. Steering shaft will be installed following the installation of body lift kit.

Front of Vehicle

1. Front bumper
 - a. Remove factory bolts securing front bumper.
 - b. Remove front bumper.

Underside of Vehicle

1. Automatic transmission
 - a. Transmission is shifted via a cable. Check cable to ensure enough slack is available. No modification should be necessary.
2. Manual transmission
 - a. Shift lever should simply drop down into floor. It may be necessary to modify floorboard or shift lever after lifting body.
3. Transfer case (4WD)
 - a. Shift lever should simply drop down into floor. It may be necessary to modify floorboard or shift lever after lifting body.

4. Fuel filler

- e. Remove body mounting bolts from passenger side only.

⚠ WARNING

Use extreme caution when working near the fuel lines and the fuel tank. Clean up spilled fuel immediately. A spark could cause an explosion or fire resulting in serious personal injury and property damage.

- a. Check fuel filler hose for ample flex and reach. Fuel filler hose may need adjusting following installation.

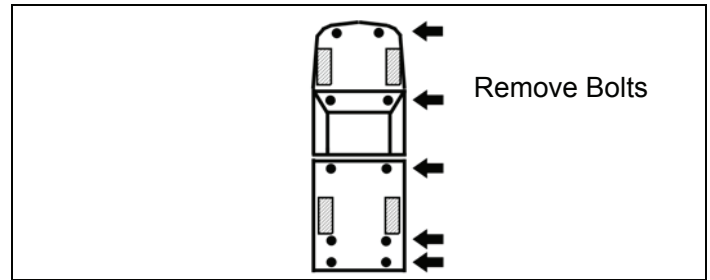

⚠ WARNING

Use extreme caution when lifting body from frame. To prevent serious personal injury, ensure the lifting device is securely placed. Keep your hands out from between the body and frame.

⚠ CAUTION

Continually check hoses, wires, lines, etc. to be sure that everything is flexing properly and not binding, or damage to the vehicle could result. Be especially careful of the A/C hoses at the firewall, the belt pulley, the core support and the fuel tank neck (if equipped with fuel tank behind seat.). Ensure brake lines stretch while lifting. Bending the lines to gain ample slack may be necessary. Be extremely careful not to kink the lines.

Install Kit

Body

1. Prepare to lift body from frame.

- a. Remove screws mounting kick panels and door jamb scuff plates. Remove kick panels and door jamb scuff plates. Pull carpet back to reveal access covers above body mount bolts. Remove access covers.
- b. Remove two (2) screws mounting each rear kick panels. Remove rear kick panels. Pull carpet back to reveal four (4) access covers above body mount bolts. Remove access covers.
- c. Remove screws mounting rear scuff plate to body at rear tailgate area. Remove screws mounting each side panel to body. Pull side panels out enough for carpet to be moved enough to expose access covers above body mount bolts. Remove access covers.
- d. Loosen, but DO NOT remove, ten (10) body mounting bolts. Bolts are located, one on each side, as follows

2. Lift passenger side of body.

- a. Using a hydraulic jack and a wooden block, slowly raise passenger side of body just high enough to remove front body mount bushing near radiator.

⚠ WARNING

The kit **blocks** must be installed in addition to the factory bushings. Installing the kit **blocks** without the factory bushings could result in damage to the vehicle or serious personal injury.

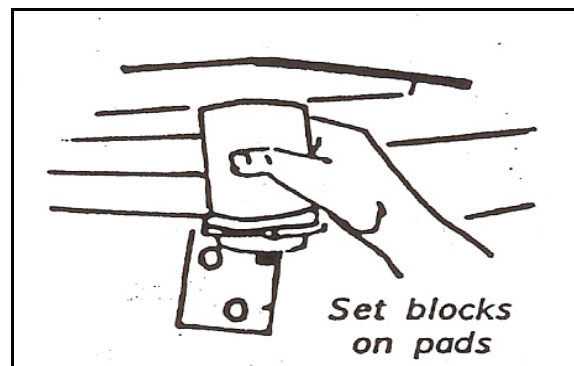
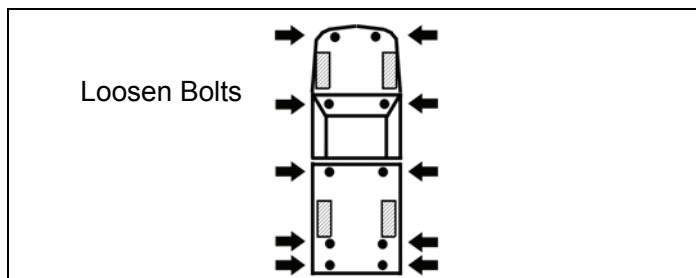

- b. Remove front body bushing from frame pad. Drill out threads using a 1/2" drill on inside of bushing sleeve.
- c. Place **kit block** on top of bushing at each mount. Install **kit bolts** and **washers** as shown. DO NOT TIGHTEN at this time.

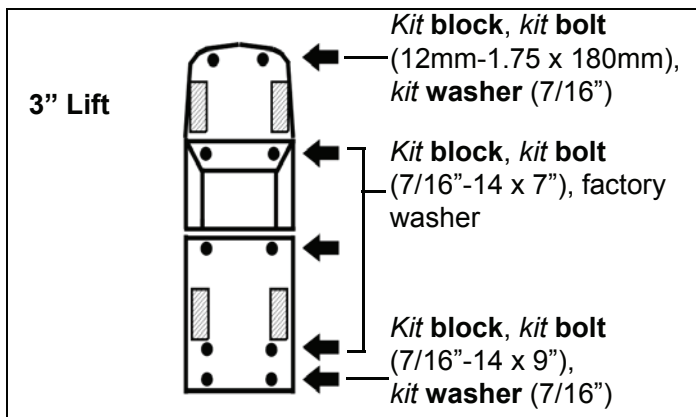
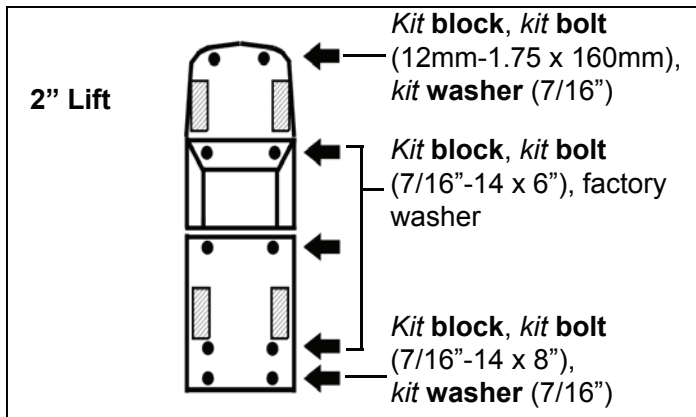

- d. Lower body onto **kit blocks**.
3. Lift driver side of body.
 - a. Repeat previous steps for driver side of body.
 - b. Remove each **kit bolt** one at a time, apply **kit Loctite®** to threads, and install **kit bolt** with **kit washer** (or factory washer). Tighten **kit bolts** to manufacturer's specification.
 - c. Install access hole covers on floor. Lay carpet back to its original position. Install rear panels. Install rear scuff plate. Install rear kick panels. Install front kick panels and door jamb scuff plates.

Fuel filler

⚠ WARNING

Use extreme caution when working near the fuel lines and the fuel tank. Clean up spilled fuel immediately. A spark could cause an explosion or fire resulting in serious personal injury and property damage.

1. Check fuel filler hose for ample slack. If additional slack is required, loosen hose clamps at either end. Adjust hose by sliding at either end until ample slack is obtained. Tighten both hose clamps securely.

Steering shaft

1. Install steering shaft into **kit steering extension**. Ensure shaft is in **kit steering extension** entirely.



2. Apply **kit Loctite®** to threads and install **kit bolt** (3/8"-24 x 1-1/4") into **kit steering extension**. Ensure **kit bolt** passes through slot on steering shaft.
3. Tighten **kit bolt** securely.

Manual transmission shift linkage

1. If transmission cannot be shifted into all gears, remove shift boot. Check shift operation again.
 - a. Make a note of where shift lever contacts floor. Cut piece from front and back of boot bracket and/or floor according to diagram below.

NOTE:

If shift lever does not engage all gears properly, and/or floor cutting is not desired, shift lever may need to be bent. Remove shift lever from vehicle and heat shift lever to bend.

⚠ CAUTION

DO NOT DAMAGE shift lever when bending!

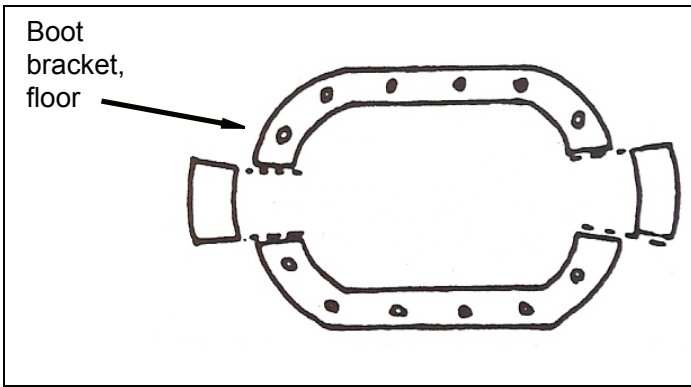

Transfer case shift linkage (4WD)

1. If transfer case cannot be shifted into all gears, remove shift boot. Check shift operation again.
 - a. Make a note of where shift lever contacts floor. Cut piece from front and back of boot bracket and/or floor according to diagram below.

NOTE:
If shift lever does not engage all gears properly, and/or floor cutting is not desired, shift lever may need to be bent. Remove shift lever from vehicle and heat shift lever to bend.

⚠ CAUTION
DO NOT DAMAGE shift lever when bending!

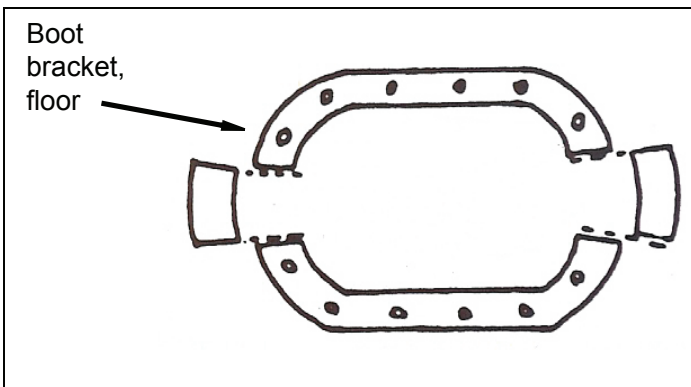

Fan shroud

1. Install **kit brackets** (upper fan shroud)

- a. Install two (2) **kit brackets** to top of radiator using factory bolts and two (2) **kit washers** (1/4" SAE) on each **kit bracket** to space away from radiator. DO NOT TIGHTEN.

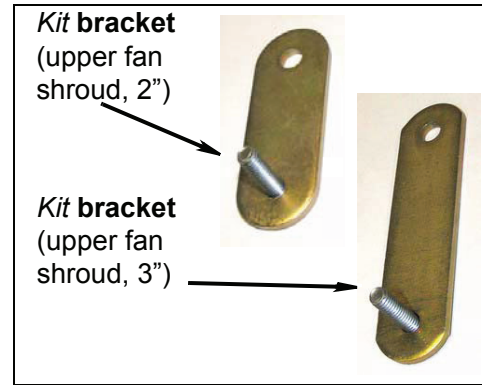

- b. Mount fan shroud to studs on **kit brackets**. Install **kit washer** (1/4" SAE) and **kit bolt** (1/4"-20 Nylock) on each stud. DO NOT TIGHTEN.

NOTE:
Vehicles equipped with automatic transmission may need to have transmission cooling lines carefully lowered to allow fan shroud to be lowered.

- c. Adjust fan to fan shroud clearance, ensuring equal distance from side to side.
- d. Remove factory bolts and apply **kit Loctite®** to threads and install. Tighten all fan shroud hardware securely.

2. Install **kit bracket** (lower fan shroud).
 - a. Remove center factory bolt mounting vertical support to bottom of core support.
 - b. Mount **kit bracket** using factory bolt between vertical support and core support.

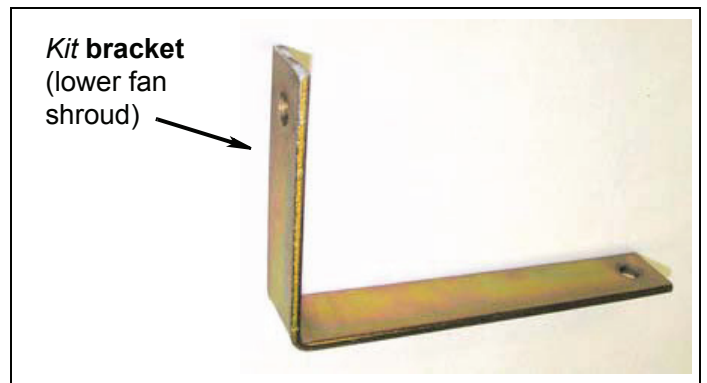

- c. Align **kit bracket** with bottom of fan shroud. Pull fan shroud against radiator.
- d. Mark fan shroud through hole in **kit bracket**.
- e. Drill 1/4" hole through fan shroud.
- f. Mount fan shroud to **kit bracket** using **kit bolt** (1/4"-20 x 1"), **kit washer** (1/4" SAE) and **kit nut** (1/4"-20 Nylock).
- g. Ensure **kit bolt** is pointing downward to prevent contact between **kit bolt** and fan.
- h. Ensure fan shroud has clearance away from fan.
- i. Remove factory bolts and apply **kit Loctite®** to threads and install. Tighten all hardware.

Engine compartment

- 1. Install air intake duct.
 - a. Install air intake duct to top of core support above radiator.
- 2. Install smog canister.
 - a. Ensure ample slack in hose running between smog pump and smog canister.
 - b. Mount smog canister in original position, if possible.
 - c. If smog canister can not be mounted in original position, drill two (2) new mounting holes closer to engine.
 - d. Mount smog canister to new holes. Tighten mounting nuts securely.

Front bumper

- 1. Install front bumper.

- a. Install front bumper in stock location, if desired.

NOTE:

Frame horns will be notched in order to raise front bumper. If frame notching is not desired, install front bumper in factory location with factory hardware. Otherwise continue installing kit.

- 2. Raise and install front bumper.

- a. Notch frame horns 2-1/2" upward and 3" backward as shown below.

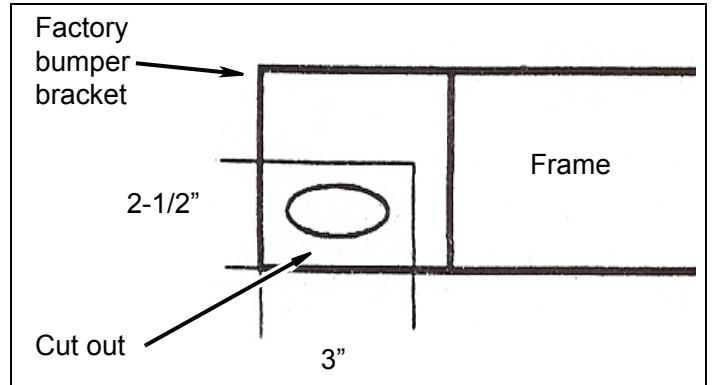

- b. Mount **kit brackets** (bumper) and bumper to factory frame brackets as shown below.

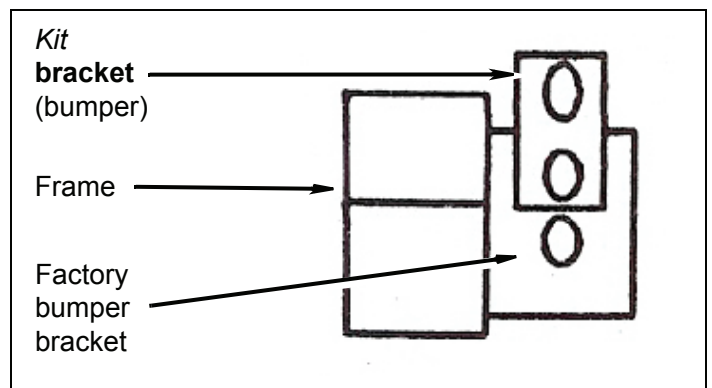
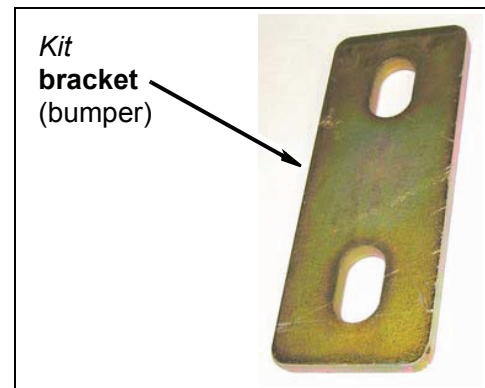

- c. Install factory bumper bolt through factory bumper bracket, then through top hole in frame mount and then through bottom hole in **kit bracket**
- d. Install factory nut on factory bumper bolt. DO NOT TIGHTEN.
- e. Install **kit bolt** (7/16"-14 x 1-1/2") and **kit washer** (7/16" USS) through top hole in factory bumper bracket mounted to bumper and then through top hole in **kit bracket**.
- f. Use additional **kit washers** (7/16" USS) to shim between factory bumper bracket and **kit bracket** for proper alignment of bumper to body as shown below.

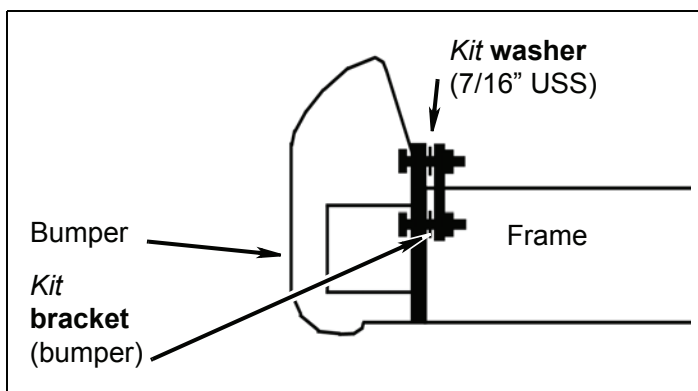

- g. Install **kit washer** (7/16" USS) and **kit nut** (7/16"-14 Nylock) on **kit bolt** (7/16"-14 x 1-1/2"). DO NOT TIGHTEN.
- h. Adjust bumper to body clearance.
- i. Remove factory bolts and apply **kit Loctite®** to threads and install. Tighten all bumper hardware securely.

NOTE:

Kit brackets (bumper) are designed to support weight of factory bumper only. They are not designed to support additional weight of an aftermarket bumper or brush guard.

⚠ CAUTION

Any attempt to use **kit brackets** (bumper) to support any bumper other than factory bumper may result in damage to vehicle and possible personal injury.

After Completing Installation

Airbag fuse

1. Install airbag fuse (if equipped).

Battery cables

1. Connect both battery cables. Connect positive cable first, then negative cable.

Miscellaneous

1. Apply **kit label** (warning) to dashboard in plain sight of all vehicle occupants.
2. Check all fasteners to ensure they are tight.
3. Adjust the headlights.
4. Ensure all wires, hoses, cables, etc. are properly connected and there is ample slack.

Dynamic Vehicle Check

1. Test-drive vehicle. Check steering in both directions to ensure that there is no bind. Check operation of clutch, brake system, and parking brake. Check operation of transmission and transfer case. Ensure there is full engagement in all gears and 4WD ranges. Check battery connections and electrical component operations.

⚠ CAUTION

Performance Automotive Group does not recommend any particular wheel and tire combinations for use with its body lifts and cannot assume responsibility for the customer's choice of wheels and tires. Refer to your owner's manual for recommended tire sizes and warnings related to the use of oversized tires. Larger wheel and tire combinations increase stress and wear on steering and suspension components, which leads to increased maintenance and higher risk for component failure. Larger wheel and tire combinations also alter speedometer calibration, braking effectiveness, center of gravity, and handling characteristics. Consult an experienced local off road shop to find what wheel and tire combinations work best with your vehicle.

△NOTE

All warranty information, instruction sheets, and other documents regarding the installation of this product must be retained by the vehicle owner. Information contained in the instructions and on the warranty card will be required for any warranty claims. The vehicle owner needs to understand the modifications made to the vehicle and how they affect vehicle handling and performance. Failure to provide the customer with this information can result in damage to the vehicle and severe personal injury.

△ NOTE

Depending on the vehicle configuration (automatic or manual transmission, 2WD or 4WD, cab length, bed length, etc.), some parts may not be used.

△WARNING

Retorque all fasteners after 500 miles and after off road use. All body lift components should be visually inspected and fasteners retorqued during routine vehicle servicing.

Parts List

Qty Description

2" Lift

Kit 842

10	Block, 2" Lift
2	Bracket, upper fan shroud
1	Bracket, lower fan shroud
2	Bracket, bumper
1	Bolt, 1/4"-20 x 1"
1	Bolt, 3/8"-24 x 1-1/4"
2	Bolt, 12mm-1.75 x 160mm
2	Bolt, 7/16"-14 x 1-1/2"
6	Bolt, 7/16"-14 x 6"
2	Bolt, 7/16"-14 x 8"
1	Label, Logo
1	Label, Warning
1	Loctite®
3	Nut, 1/4"-20 Nylock
2	Nut, 7/16"-14 Nylock
1	Steering Extension
8	Washer, 1/4" SAE
16	Washer, 7/16" USS
1	Instruction set

3" Lift

Kit 843

10	Block, 3" Lift
2	Bracket, upper fan shroud
1	Bracket, lower fan shroud
2	Bracket, bumper
1	Bolt, 1/4"-20 x 1"
1	Bolt, 3/8"-24 x 1-1/4"
2	Bolt, 12mm-1.75 x 180mm
2	Bolt, 7/16"-14 x 1-1/2"
6	Bolt, 7/16"-14 x 7"
2	Bolt, 7/16"-14 x 9"
1	Label, Logo
1	Label, Warning
1	Loctite®
3	Nut, 1/4"-20 Nylock
2	Nut, 7/16"-14 Nylock
1	Steering Extension
8	Washer, 1/4" SAE
16	Washer, 7/16" USS
1	Instruction set