



## INSTALLATION INSTRUCTIONS

1075 North Ave. Sanger, CA 93657-3539 toll free: 800-445-3767 web: www.belltechcorp.com

### 5454 FRONT ASB MITSUBISHI PICK-UP

**Congratulations! You were selective enough to choose a BELLTECH PRODUCT. We have spent many hours developing our line of products so that you will receive maximum performance with minimum difficulty during installation.**

- Note: Confirm that all of the hardware listed in the parts list is in the kit. **Do not** begin installation if any part is missing. Read the instructions thoroughly before beginning this installation.
- Warning:** **DO NOT** work under a vehicle supported by only a jack. Place support stands securely under the vehicle in the manufacturer's specified locations unless otherwise instructed.
- Warning:** **DO NOT** drive vehicle until all work has been completed and checked. Torque all hardware to values specified.
- Reminder: Proper use of safety equipment and eye/face/hand protection is absolutely necessary when using these tools to perform procedures!
- Note: It is very helpful to have an assistant available during installation.

#### RECOMMENDED TOOLS:

- Properly rated floor jack, support stands, and wheel chocks
- Combination wrench set
- Torque wrench: *0-75 lb ft. range*
- Ratcheting socket wrench and sockets sets
- Safety Glasses

#### KIT INSTALLATION

1. Open the hardware kit and remove all of the contents. Refer to the part list (Page 3) to verify that all parts are present.
2. Park the vehicle on a smooth, level concrete or seasoned asphalt surface and activate the parking brake. Block the REAR wheels of the vehicle with appropriate wheel chocks; making sure the vehicle's transmission is in 1<sup>st</sup> gear (manual) or "Park" (automatic).
3. Using a properly rated floor jack, lift the FRONT wheels of the vehicle off the ground. Place support stands, rated for the vehicle's weight, and in the factory specified locations. Refer to the vehicle Owner's Manual. Prior to lowering the vehicle onto the stands, make sure the supports will securely contact the chassis.
4. It is very important that the vehicle is properly supported during this installation to prevent personal injury and chassis damage! Make sure that the supports stands are properly placed prior to performing the following procedures. We **DO NOT RECOMMEND** using wheel ramps while performing this installation.
5. Slowly lower the vehicle onto the stands and, before placing the vehicle's entire weight on them, again check that they properly and securely contact the chassis as described above. Check for possible interference with any lines, wires, cables, or other easily damaged components.

6. Remove the splash pan. Remove the end links from the ends of the original equipment Anti-Sway Bar. Remove the bushing brackets as well. Note the position of the Anti-Sway Bar in the vehicle to ease in the installation of your new Belltech Anti-Sway Bar.
7. Remove the eight bolts (four from each side) from the front position of tension compression rod units. Remove both nuts from the bottom of each rubber bump stop. Remove bump stops. Remove both tension compression units and Anti-Sway Bar as one complete unit.
8. Slide tension compression units off ends of original equipment Anti-Sway Bar.
9. Slide tension compression units onto your new Belltech Anti-Sway Bar. Position complete unit on vehicle. Loosely fasten front portion of tension compression units to chassis using the original equipment bolts just removed.
10. Loosely fasten ends of tension compression rods to control arms using your original equipment bump stops.
11. Thoroughly lubricate the **inside** of your new hyper thane bushing using the grease packet included in the kit. Place the bushings on the new Anti-Sway Bar. Refer to the original equipment Anti-Sway bar as to the proper bushing location.
12. Fasten center portion of the Anti-Sway Bar to tension compression units using the original equipment brackets and bolts. Torque bolts to 13 ft/lbs.
13. Go back and torque all tension compression unit bolts and bump stops to 38 ft/lbs.
14. Install the kit supplied end links as shown on the attached sheet. Tighten the nut on the end link bolt so that only the center spacer sleeve can be rotated firmly by hand.
15. Re-install splash pan and wheels.
16. All hardware being fastened to the vehicle's original fastening points should be torqued to the proper specifications. To prevent chassis damage, never over-torque the hardware.
17. Check that all components and fasteners have been properly installed, tightened and torqued.
18. Check brake hoses, and other components for any possible interference.
19. Lift vehicle and remove support stands. Carefully lower vehicle to ground.
20. Immediately test-drive the vehicle in a remote location so that you can become accustomed to the revised driving characteristics and handling. Be aware that the vehicle will handle substantially different now that it has been modified.
21. Installation is complete. Check all of the hardware and re-torque at intervals for the first 10, 100, 1000 miles.

## PART LIST FOR ANTI-SWAY BAR KIT

PART No.	DESCRIPTION	QTY.
5454-300	Rear ASB	1
110255	Nylon Insert Lock Nut 3/8" -16	2
112126	HH Cap Screw 3/8" -16 x 5"	2
112474	Spacer Tube 3/4" x 3/8"	2
112502	Cup Washer Large	8
113000	End Link Grommet	8
113125	Pivot Bushing 1"	2
55000-10	Grease Pack	1

### BELLTECH INSTALLATION TIPS

#### LUBRICATION

Pre-lubricating the inside of the bushing before it's installed is important because the lubrication will greatly reduce noise and it will increase bushing life. Belltech recommends you use Molybdenum disulfide. This will help protect the inside surface of the bushing and will last longer than most types of grease. Thoroughly lubricate the inside of the bushing with this grease.

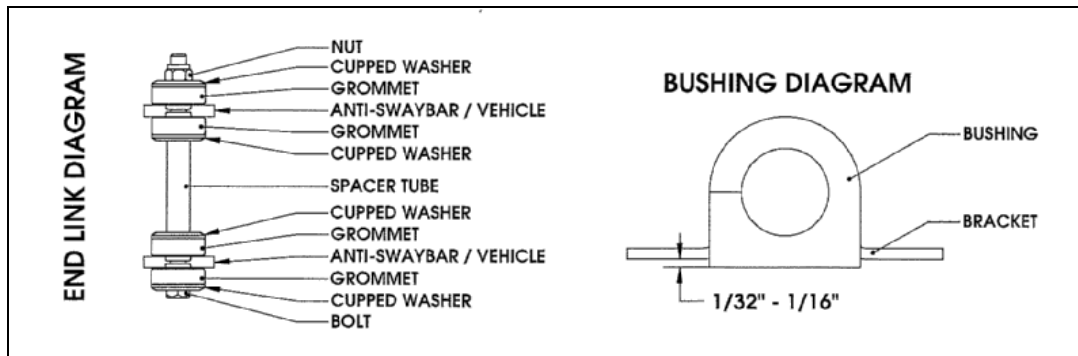

#### BUSHING INSTALLATION

Make sure an amount of 1/32" to 1/16" of the bushing is showing when you install it onto the bracket. See the diagram above. If the bushing is showing more than 1/16" than use a sander or a sheet of coarse grit sand paper to shave it down to the proper height. In most applications when installing the new bushings on your Belltech Anti-Sway Bar you may refer to your original equipment Anti-Sway Bar to locate the proper location.

## END LINK INSTALLATION

It is not required that you use lubricant on the end links since there is not any rotational movement. The Belltech end links are comprised of grommets, cupped washers, a spacer tube, bolt, and lock nut, these assembled components create the end link. See END LINK DIAGRAM on Page 3.

## AXLE CLAMP DIAGRAM

