



INSTALLATION INSTRUCTIONS

1075 North Ave. Sanger, CA 93657-3539 local: 559-875-0222 fax: 559-876-2259 toll free: 800-445-3767

5404 FRONT ANTI-SWAY BAR C-10 PICK-UP

CONGRATULATIONS!

You were selective enough to choose a **BELLTECH PRODUCT**. We have spent many hours developing our line of products so that you will receive maximum performance with minimum difficulty during installation

Note: Confirm that all of the hardware listed in the parts list is in the kit. **DO NOT** begin this installation if any part is missing. Read the instructions thoroughly before beginning this installation.

Warning: **DO NOT** work under a vehicle supported by only a jack. Place support stands securely under the vehicle in the manufacturer's specified locations unless otherwise instructed.

Warning: **DO NOT** drive the vehicle until all work has been completed and checked. Torque all hardware to values specified.

Reminder: Proper use of safety equipment and eye/face/hand protection is absolutely necessary when using these tools to perform procedures!

Note: It is very helpful to have an assistant available during the installation process.

Note: We **DO NOT RECOMMEND** using wheel ramps while performing this installation.

RECOMMENDED TOOLS:

- Blocks and Wheel chocks
- Ratcheting Socket Wrench
- Safety Glasses
- Properly rated floor jacks and support stands
- Combination Wrench
- Torque wrench: 0-75 lb ft. range

1 KIT INSTALLATION

- 1a.** Open the hardware kit and remove all of the contents. Refer to the parts list (Page 3) to verify that all parts are present.
- 1b.** Park the vehicle on a smooth, level concrete or seasoned asphalt surface and activate the parking brake. Block the FRONT wheels of the vehicle with appropriate wheel chocks; making sure the vehicle's transmission is in 1st gear (manual) or "Park" (automatic).
- 1c.** Using a properly rated floor jack, lift the REAR wheels of the vehicle off the ground. Place support stands, rated for the vehicle's weight and in the factory specified locations. Refer to the vehicle Owner's Manual. Prior to lowering the vehicle onto the stands, make sure the supports will securely contact the chassis.
- 1d.** It is very important that the vehicle is properly supported during this installation to prevent personal injury and chassis damage. Make sure that the support stands are properly placed prior to performing the following procedures. We **DO NOT RECOMMEND** using wheel ramps while performing this installation.

- 1e. Slowly lower the vehicle onto the stands and, before placing the vehicle's entire weight on them, again check that they properly and securely contact the chassis as described above. Check for possible interference with any lines, wires, cables, or other easily damaged components.

NOTE:

If the vehicle does not have an original equipment Anti-Sway Bar, you will have to purchase a Belltech adapter kit P/N 5704.

2. REMOVING THE ORIGINAL EQUIPMENT ANTI-SWAY BAR

- 2a. There are four mount bushings that contain the original equipment Anti-Sway Bar. Remove all four bushing brackets and bushings.
- 2b. Remove the original equipment Anti-Sway Bar.

3. MODIFYING THE LOWER CONTROL ARM

- 3a. Located on the top outside edge of each lower control arm, there are two mounting holes to mount the bushing brackets that secure the ends of the Anti-Sway Bar (Photo 1). The outside holes will need to be drilled to accommodate the end link.
- 3b. Using a 5/8" drill bit, drill a clearance hole for the end link at the existing outer hole To be done on both Lower Control Arms.

4. INSTALLING THE NEW ANTI-SWAY BAR

- 4a. Thoroughly lubricate the inside of the new hyperthane bushings (Photo 2), using the grease packet included in the kit. Place the bushings on the new Anti-Sway, locating them in the area of the original equipment Anti-Sway Bar.
- 4b. Using an adjustable jack (Photo 3), place the center of the new Anti-Sway Bar atop the adjustable jack. The ends of the new Anti-Sway Bar need to be located atop the Lower Control Arm (A-Arm) (Photo 4).
- 4c. Install the new bushing brackets around the bushings and mount them to the existing bracket mount, finger-tightening them only (Photo 5).
- 4d. Install the new end links at the new 5/8" dia. clearance hole. From the underside of the Lower Control Arm, install the End Link Grommet (Photo 6).

See **Fig. 1** for the proper orientation of how the end link and grommets assemble. Fig.2 describes the bushing details.
- 4e. The mount end of the new Anti-Sway Bar shows the orientation of the grommets located on the end link (Photo 7).
- 4f. Remove the adjustable jack stand and tighten hardware.

5. FINALIZING THE INSTALLATION

- 5a.** Tighten the bushing bracket and tighten to 18ft-lbs.

All hardware being fastened to the vehicle's original fastening points should be torqued to the proper specifications. To prevent chassis damage, never over-torque the hardware.

- 5b.** Check that all components and fasteners have been properly installed, tightened and torqued.
- 5c.** Check brake hoses and other components for any possible interference.
- 5d.** Lift the vehicle and remove the support stands. Carefully lower the vehicle to the ground.
- 5e.** Immediately test-drive the vehicle in a remote location so that you can become accustomed to the revised driving characteristics and handling. Be aware that the vehicle will handle substantially different now that it has been modified.
- 5f.** Installation is complete. Check all of the hardware and re-torque at intervals for the first 10, 100, 1000 miles.

Below in **Fig. 1**, the assembly orientation of the end links is shown. In Fig. 1, A-Arm location is where the Lower Control Arm will be located.

In **Fig. 2**, its important that this installation be followed to insure proper mounting of the bushing and bracket as it mounts to the vehicle chassis.

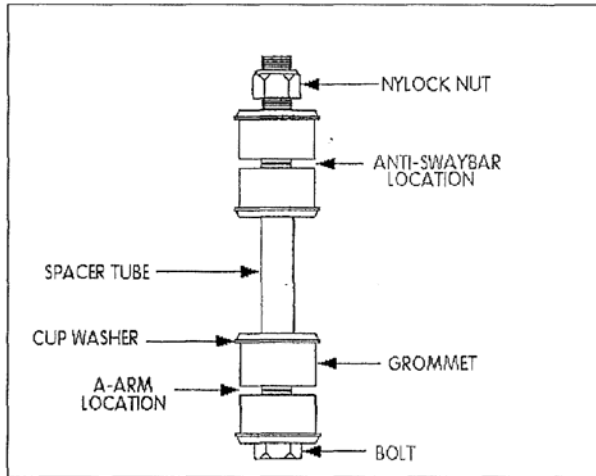

Fig. 1

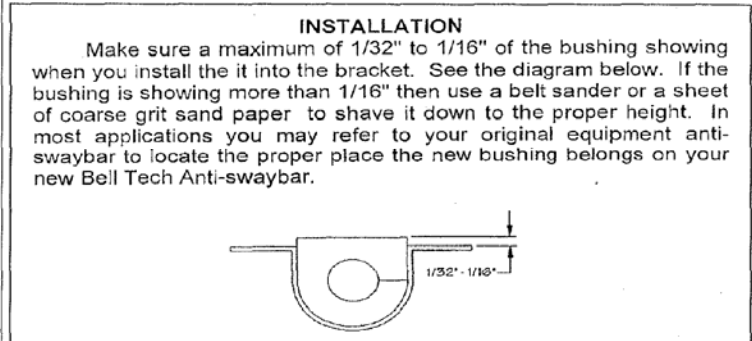

Fig. 2

PART NO.	DESCRIPTION	QTY
5404-300	Front Anti-Sway Bar	1
110255	Nylon Insert Lock Nut 3/8"-16	6
112086	HH Cap Screw 3/8"-16 x 1"	4
112126	HH Cap Screw 3/8"-16 x 5"	2
112444	Spacer Tube 1/2" x .049 x .500	2
112502	Cup Washer Large	6
112518	Flat Washer 3/8"	10
113000	End Link Grommet	8
113245	Pivot Bushing	2
55000-10	Grease Pack	1
114029	Pivot Bushing Bracket	2

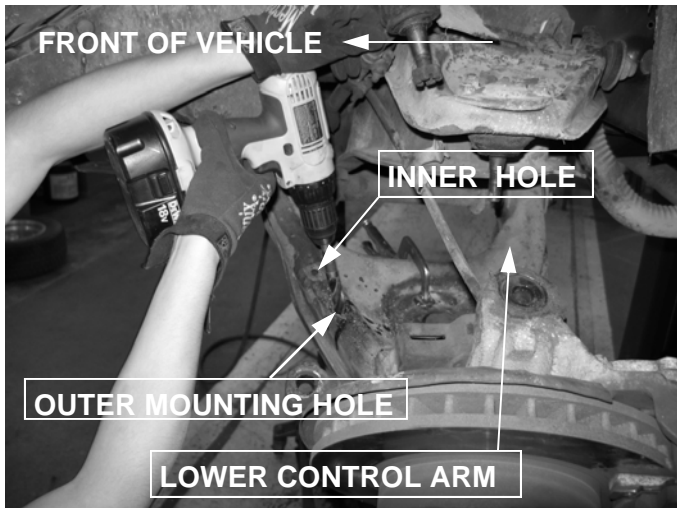

PHOTO 1

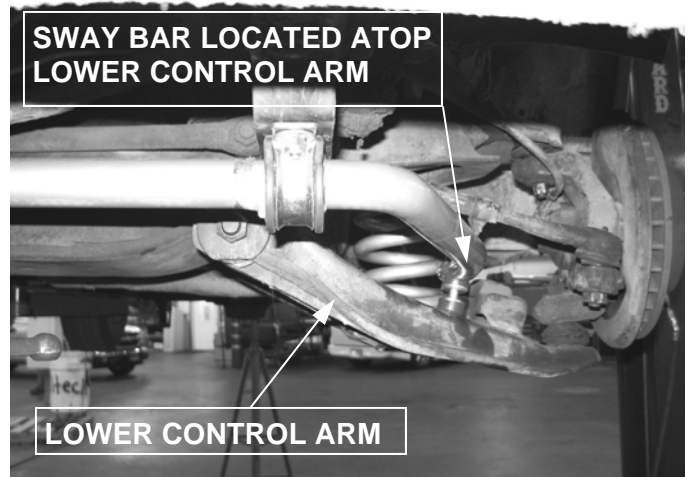

PHOTO 4



PHOTO 2



PHOTO 5

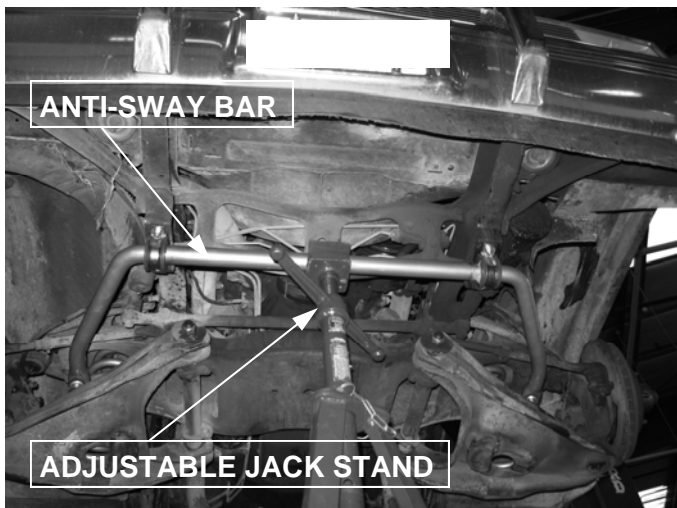

PHOTO 3



PHOTO 6

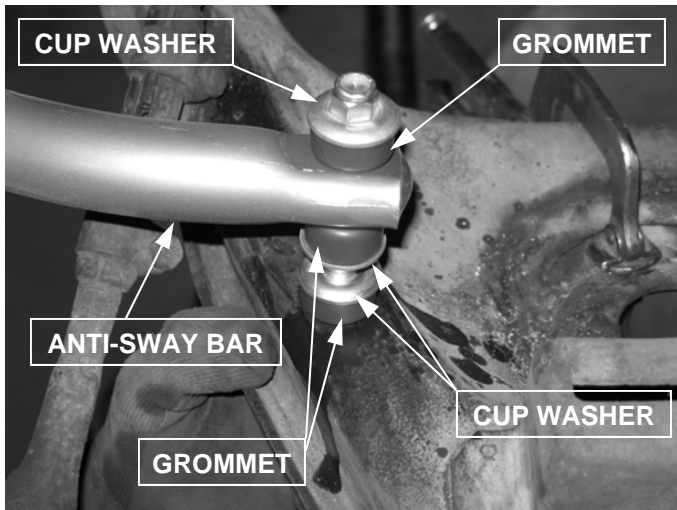

PHOTO 7

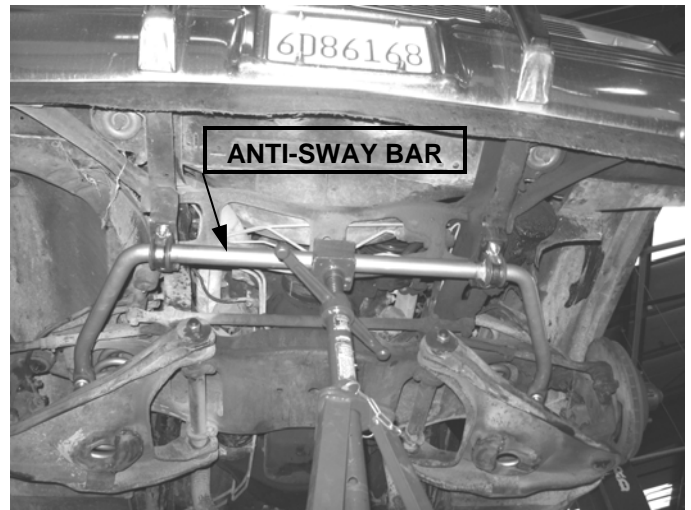

PHOTO 8

In (Photo 7) above, the assembly orientation of the end link is shown as it is mounted to the Lower Control Arm.