



INSTALLATION INSTRUCTIONS

300 W. Pontiac Way Clovis, CA 93612 toll free: 1-800-445-3767 web: www.belltech.com

5650 REAR ANTI SWAY BAR KIT CHEVY TAHOE & YUKON 4-WD

Thank you for being selective enough to choose our high quality BELLTECH PRODUCT. We have spent many hours developing our line of products so that you will receive maximum performance with minimum difficulty during installation.

- Note: Confirm that all of the hardware listed in the parts list is in the kit. **Do not** begin installation if any part is missing. Read the instructions thoroughly before beginning this installation.
- Warning:** **DO NOT** work under a vehicle supported by only a jack. Place support stands securely under the vehicle in the manufacturer's specified locations unless otherwise instructed.
- Warning:** **DO NOT** drive vehicle until all work has been completed and checked. Torque all hardware to values specified.
- Reminder: Proper use of safety equipment and eye/face/hand protection is absolutely necessary when using these tools to perform procedures!
- Note: It is very helpful to have an assistant available during installation.

RECOMMENDED TOOLS:

- Properly rated floor jack, support stands, and wheel chocks
- Combination wrench set
- Torque wrench: *0-75 lb ft. range*
- Ratcheting socket wrench and socket sets
- Air Chisel / Die grinder W/ cut off wheel
- Safety Glasses

KIT INSTALLATION

1. Open the hardware kit and remove all of the contents. Refer to the part list (page 2) to verify that all parts are present.
2. Park the vehicle on a smooth level asphalt or concrete surface. Place a block in front of and behind the front wheels. Jack up the rear of the vehicle and place jack stands securely under the frame in the manufacturer's specified locations. Remove the rear wheels.
3. To determine the proper mounting position of the new Belltech Anti-Sway Bar, lay it on a flat surface. The center of the bar should touch the ground and the ends of the bar point to the front of the vehicle.
4. Thoroughly lubricate the inside of your new hyperthane bushings using the lubricant provided. Position the bushings on the new Anti-Sway Bar inside the outer most bend.
5. Install the 3" U-clamps over the axle tubes. Make sure the brake lines are not underneath the clamps or else damage leading to the brakes will cause failure. Carefully bend the brake lines out of the way if required, place the bushing plate and bushing bracket on the U-clamp and hand tighten one nut. Leave one side off for now. Position the bar below the axle housing.

6. Center the Anti-Sway Bar left to right and front to rear. The Anti-Sway Bar must be directly below the axle tubes. Position the clamps to the widest spacing possible to prevent the bar from shifting while cornering. Tighten the U-bolts to 18 ft/lbs of torque.
7. Slide the bar under the axle and position the ends of the arms parallel with the frame rails. Assemble the end links onto the Anti-Sway Bar as shown in diagram. **NOTE: Stock height vehicles will have different end link configurations than lowered vehicles.** Attach the wheels and lower the vehicle to the ground. The vehicle must be at ride height before making the holes. Position a bolt through the hole in the end of the Anti-Sway Bar pointing up and mark the frame rails for drilling. Check to see if there are any wires or brake lines in the way before drilling, and move them out of the way if necessary. Drill through the bottom leg of the frame rail using a 9/16" of 5/8" drill bit. Repeat this procedure on the other side of the vehicle.
8. Assemble the end links to the frame and the Anti-Sway Bar.
9. Go over the entire installation procedure and make sure all appropriate fasteners are properly tight. Install the wheels and lower the vehicle. Installation is complete.

Immediately test-drive the vehicle in a remote location so that you can become accustomed to the revised driving characteristics and handling. Be aware that the vehicle will handle substantially different now that it has been modified.

**PART LIST FOR 5650
REAR ANTI SWAY BAR KIT**

PART No.	DESCRIPTION	QTY.
5500-300	Rear Anti Sway Bar	1
113075	Pivot Bushing 1"	2
113000	Grommet	8
112258	3" U-Clamp	2
114038	Under Support Plate	2
114026	Bushing Bracket	2
112502	Cupped Washer Large	8
112436	Spacer Tube 4" x 3/8"	2
110625	Flat Washer 3/8"	4
110255	3/8"-16 Ny Lock Nut	2
112148	3/8"-16 x 9" HHCS	2
55000-10	Grease Pack	1

! BELLTECH INSTALLATION TIPS

LUBRICATION

Pre-lubricating the inside of the bushing before it's installed is important because the lubrication will greatly reduce noise and it will increase bushing life. Belltech recommends you use Molybdenum disulfide. This will help protect the inside surface of the bushing and will last longer than most types of grease. Thoroughly lubricate the inside of the bushing with this grease.

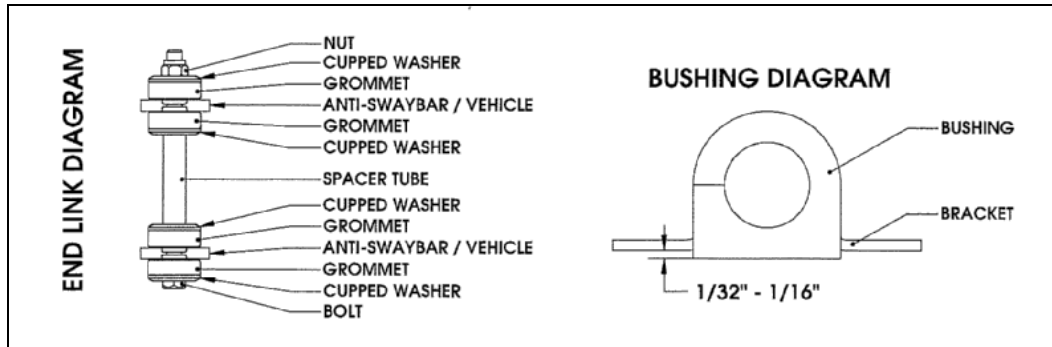

BUSHING INSTALLATION

Make sure an amount of 1/32" to 1/16" of the bushing is showing when you install it onto the bracket. See the diagram above. If the bushing is showing more than 1/16" then use a sander or a sheet of coarse grit sand paper to shave it down to the proper height. In most applications when installing the new bushings on your Belltech Anti-Sway Bar you may refer to your original equipment Anti-Sway Bar to locate the proper location.

END LINK INSTALLATION

It is not required that you use lubricant on the end links since there is not any rotational movement. The Belltech end links are comprised of grommets, cupped washers, a spacer tube, bolt, and lock nut, these assembled components create the end link. See END LINK DIAGRAM above.

Axle Clamp Diagram

