

IMPORTANT NOTICE

Ball Joint Info:

Before you install this product, please verify which front spindles you have. We have designed the upper a-arms to utilize the 73-87 style spindles. This type of spindle was widely used in disc brake conversions due to its easy interchangeability and readily available replacement parts (e.g. ball joints, tie rods). The Hotchkis lower a-arm ball joints will work with spindles from 71-87. However, if you have original 71-72 style disc brake spindles and you would like to install Hotchkis upper a-arms, you will need to order ball joints from us to convert the Hotchkis upper a-arms to work with that spindle. (Part # **FA683**) If you have 63-70 drum brake spindles, you will need to upgrade your spindles and brakes to take advantage of this a-arm kit. Please call if you would like to upgrade your spindles and brakes.

Steering Stop Info:

In the following diagrams we will display 3 popular styles of spindles that your truck may be equipped with. Due to the variants in spindles that are available, you may need to modify the steering stop on your spindle to allow for proper steering angle. (Approx. 30°) Please see below.

- **73-87 Stock Height OEM Spindle**





Note: Cut angle should match steering stop nub angle

- **73-87 OEM Drop Spindle**



73 - 87 DROP SPINDLES
DRIVER SIDE



- CPP Modular Spindle (NO MODIFICATION NEEDED)

73-87 CPP MODULAR
2" DROP SPINDLE



ADJUSTABLE
STEERING STOP

LOWER A-ARMS
11390L
67 - 72 C-10 Pickup Truck

*Thank you for your purchase from our new line of Chevy parts.
Please call us at 877 - 4NO - ROLL if you have any questions
regarding the service or installation of your Hotchkis Performance products.*

IMPORTANT: PLEASE READ THE ENTIRE INSTRUCTION MANUAL BEFORE STARTING THIS INSTALLATION. THIS KIT IS INTENDED FOR TRUCKS WITH 71-72 OR 73-87 DISC BRAKE SPINDLES. YOU MUST HAVE MECHANICAL KNOWLEDGE AND EXPERIENCE TO PERFORM THIS INSTALLATION. IF YOU ARE UNCERTAIN WITH THE PROCEDURE FOR THIS KIT PLEASE HAVE THE INSTALLATION PERFORMED BY A PROFESSIONAL TECHNICIAN.



Installation of Hotchkis Lower A-Arms

1 ***Raise the Truck***

Raise the vehicle by using a drive-on alignment rack. Securely block the rear wheels of the vehicle.



2 ***Disconnect the Shock***

Unbolt the lower shock mount on the rear side of the lower A-arms.



3 ***Disconnect the Lower Ball Joint***

Remove the cotter pin from the lower ball joint stud. Use a wrench to loosen the castle nut that secures the lower ball joint to the spindle. Do not remove the castle nut entirely. Keep most of the castle nut still engaged for safety. Using a heavy hammer, hit the lower portion of the spindle to break loose the ball joint stud from the spindle. The weight of truck with the impact of the hammer should break loose the tapered press fit of the ball joint stud from the spindle. You may want to spray the stud area with penetrating oil if you're having a difficult time breaking it loose.



Once the ball joint is loose from the spindle, raise the chassis from the frame rails until the front wheels lift off the ground. Support the lower control arm with another floor jack and raise the suspension slightly to relieve the pressure on the castle nut. Remove the castle nut and SLOWLY lower the floor jack until the lower ball joint stud comes out of the spindle. The spring may have some preload in it, so carefully lower the a-arm more until the pressure is removed from the spring. Remove the spring at this point.

4 ***Disconnect Front Sway Bar End Links***

If your truck is equipped with a factory front sway bar, undo the end links that attach to the lower a-arms.

5 ***Disconnect the Lower A-Arm Cross shaft***

At this point, the only thing holding the lower a-arm to the car is the cross shaft. Undo the 2 U-bolts for each arm that secure the cross shaft to the chassis. Remove the a-arm from the vehicle.

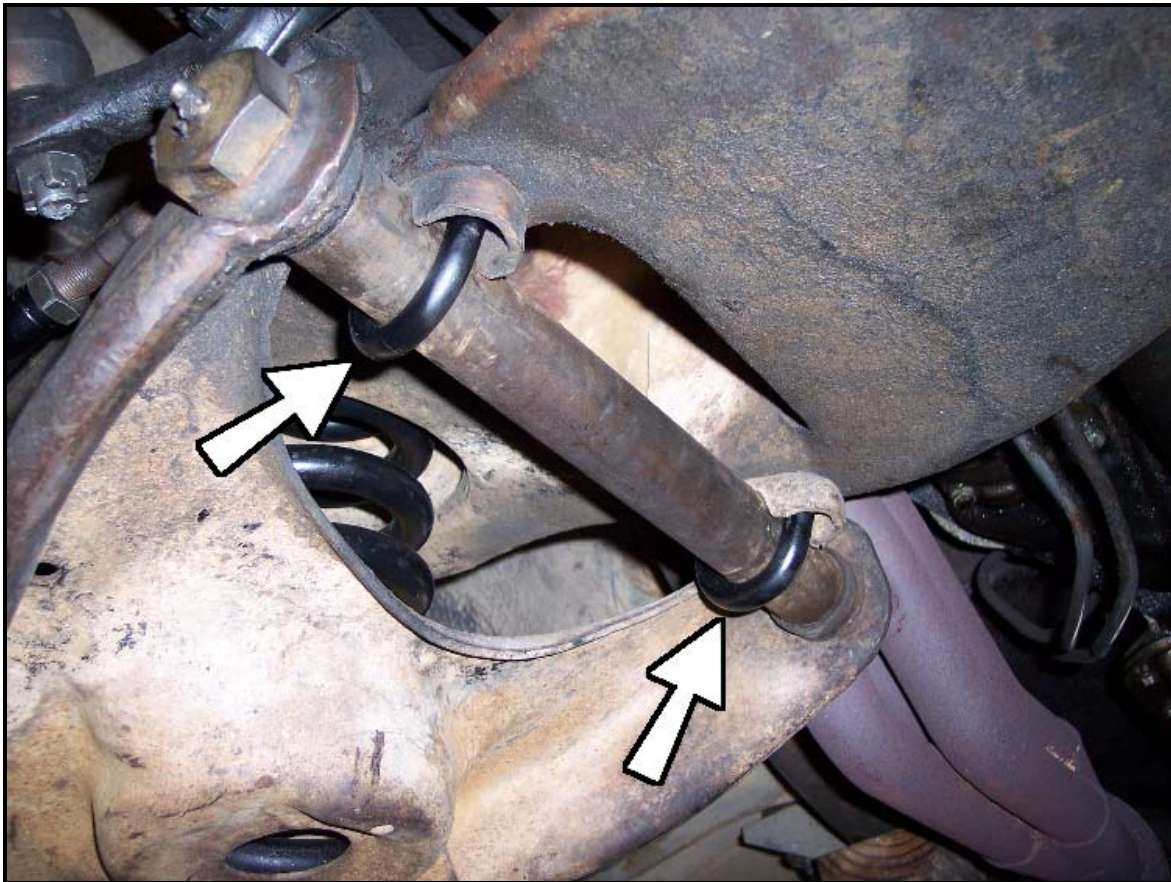

5 ***Reinstall the Hothckis Upper A-arms***

Reinstall the Hotchkis a-arms in the same manner as removal. The a-arms are side specific, so please take caution when installing them.



Please also note the orientation of the cross shaft. The front section of the cross shaft has a positioning hole that mates to the front mount on the chassis.



Install the cross shaft onto the vehicle first, using the same u-bolts that held in the stock arms. Fully tighten this hardware.

Reinstall the spring, positioning the top of the coil first. The Hotchkis a-arm includes a modular spacer and spring isolator. The spacer allows you to lower your ride height by ½" if removed. If you would like to retain the same ride height, then leave the single spacer in place. The polyurethane isolator can be clocked so that the spring can seat properly in the a-arm.

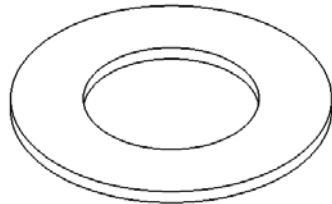

SPRING SPACER

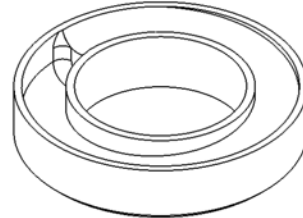

SPRING ISOLATOR

Support the bottom side of the lower a-arm with a floor jack. You should hold the coil spring in position and ready for compression.

You will need to raise the lower a-arm using your floor jack until the ball joint inserts into the spindle. Make sure your coil spring is properly seated in the top and bottom. Spin the included castle nut on the stud and fully tighten. Make sure to line up the castle nut with the cotter pin hole. Insert the cotter pin and bend to lock.

Reinstall the shocks and wheels.

Continue to the next page to begin the center link installation. You should not install the Hotchkis lower a-arms without installing the Hotchkis center link. You will have adverse bumpsteer otherwise. You may keep the front end jacked up off the ground for the time being.

Continue to next page →

1 ***Remove the Stock Steering Center Link***

Since the Hotchkis arms alter the suspension geometry to improve front end grip, the steering center link needs to be replaced to avoid any unwanted bumpsteer that is created with this change.

With the front end still off the ground, remove the cotter pins on the inner tie rod ends, idler arm, and pitman arm. Loosen all of the castle nuts associated with these cotter pins. Use a ball joint puller or pickle to disconnect each stud from the center link. The impact of a hammer may help pop some of them loose. Use penetrating oil on the tapers to help loosen them up as well.



Once you've removed the center link from the vehicle, compare it to the Hotchkis center link for proper orientation.



SPECIAL NOTE:

We include new steering tie rod turnbuckles for customers with disc brake conversions that utilize the 5/8" inner tie rods with 11/16" outer tie rods. If you have 5/8" inner and outer tie rods, then you may use your stock steering turnbuckles for this installation.

2 ***Reinstalling Hotchkis Center link***

Reinstall the Hotchkis Center link in the same manner as stock removal. Reuse or purchase new cotter pins for all of the castle nuts. (Available at your local auto parts store). Reinstall all castle nuts and cotter pins in the center link.

3 ***Reinstall Front Sway Bar End Links***

If your truck was equipped with a front sway bar, use the new end links included with your a-arms. If you do not have a front sway bar, you may remove these end links from the arms. We highly recommend the use of sway bars with this kit. You are now finished with this installation.



- You will need to perform a front end wheel alignment after this installation.

Check out our other great products for your C10 Pickup at Hotchkis.net

- 19390 Sport Coil Springs (4/6 Drop)
- 11390U Tubular Upper A-Arms (Improved Camber Curve)
- 11390L Tubular Lower A-Arms (Increased Caster for Stability and Cornering Grip)
- 18390 Rear Suspension Package (Quality rear shocks and longer/lower track bar for improved rear grip)
- 22390 Sway Bar Kit (Reduce Body Roll and Enhance Vehicle Response)
- 30390 Anti-Squat Kit (Increased anti-squat for better launches)
- 70390 Front Shock Kit (Re-positions front Bilstein shocks for more travel for lowered trucks)



Hotchkis Performance LLC Return Policy & Limited Warranty

Effective December 1, 2010 all Hotchkis products must be registered to qualify for warranty at www.hotchkis.net or via the mail-in warranty card, included with the product, within 30 days of the original purchase date.

IMPORTANT: This warranty supersedes all other warranties included with this product.

Return Policy

We want you to be completely satisfied with your Hotchkis Performance product. For products, presenting signs of shipping damage please contact the freight carrier immediately. All our products are guaranteed to be free from manufacturer's defects. If your order arrives with a manufacture defect, please contact our Customer Service Department at (562) 907-7757. You will be assigned a Returned Goods Authorization Number (RGA). The package you return must show the RGA on the outside of the package, include the original invoice and be shipped prepaid to our facility. The product has to be unused and in its original packaging materials. Exchanges or refunds made after 30 days will be subject to a 20% restocking charge. **If you purchased your Hotchkis Performance product from an authorized dealer, you are still covered by this return policy. All returns however, should be made to your dealer, not to Hotchkis Performance directly.**

Limited Warranty

Hotchkis Performance offers a Limited Warranty against defects in materials and workmanship for the term of 36 months (3 years) from the date of purchase of this product. This Warranty only applies to the original retail purchaser who retains ownership of the vehicle on which the product was originally installed. If the product is determined to be defective, Hotchkis Performance will repair, replace or refund the purchase price of the defective product at Hotchkis Performance's sole discretion, which shall fully satisfy and discharge any and all warranty claims. Any repaired or replaced product will be returned to the sender excluding the cost of freight. **Products must be registered to qualify for warranty at www.hotchkis.net or via the mail-in warranty card, included with the product, within 30 days of the original purchase date.**

Exclusions from Warranty

Items offered but not manufactured by Hotchkis Performance are warranted according to the manufacturer's terms and are not covered by this limited warranty. Hotchkis Performance shall not be responsible for any labor, removal, installation, re-installation or maintenance costs. This warranty does not cover the cosmetic finish or plating of any product or any normal wear and tear to any product including, but not limited to bushings, brackets, end-links, hardware, steering components, shocks or springs. In addition, this warranty does not apply to any products that have been:

- Improperly installed or installed by someone other than a qualified, licensed auto mechanic experienced in the installation and removal of suspension products;
- Improperly serviced, misused, or modified, altered or subjected to abuse, negligence, accident or collision;
- Installed in any vehicle that has been modified;
- Installed on any vehicle that has carried loads in excess of automobile manufacturer suggested weight limits; or
- Installed on any vehicle that has been subject to abnormal or excessive use, including rallying, racing, or racing-type activities or off-road use.

Limitation of Warranty

This limited warranty is the entire and only warranty for the products and may not be modified or supplemented by any other person or company in any form. Any description of the products, by anyone, is for the sole purpose of identifying them and is not part of the basis of the bargain, and does not constitute a warranty that the products will conform to that description. The statements of any salesperson do not constitute part of this limited warranty and cannot be relied upon as a warranty.

THERE ARE NO WARRANTIES, EXPRESSED OR IMPLIED, INCLUDING ANY IMPLIED WARRANTIES OF MERCHANTABILITY OR FITNESS FOR A PARTICULAR PURPOSE, WHICH EXTEND BEYOND THE DESCRIPTION ON THE FACE HEREOF. ANY IMPLIED WARRANTIES ARE DISCLAIMED TO THE FULLEST EXTENT PERMITTED BY LAW. THIS WARRANTY DOES NOT COVER CONSEQUENTIAL DAMAGES, LOSS OF TIME OR REVENUES, INCONVENIENCE, LOSS



OF USE OF THE VEHICLE, DAMAGE TO THE VEHICLE OR COMPONENTS OF THE VEHICLE, ANY OTHER TYPE OF CONSEQUENTIAL DAMAGES, OR OTHER INCIDENTAL OR INDIRECT DAMAGES. HOTCHKIS' MAXIMUM LIABILITY UNDER THIS WARRANTY SHALL IN NO EVENT EXCEED THE PURCHASE PRICE OF THE PRODUCT. Some states do not allow limitations on how long an implied warranty lasts or the exclusion or limitation of incidental or consequential damages and in such states the above limitations or exclusions may not apply. This limited warranty gives the purchaser specific legal rights and the purchaser may have other rights that may vary from state to state.

Technical Information

Hotchkis Performance makes every effort to ensure that you are provided with the most accurate and up-to-date technical information. However, all technical information is approximate and may vary upon application. Additional suspension components may be needed in some applications, depending upon the make, model, engine and chassis of the vehicle. Hotchkis Performance is not responsible for any consequences resulting from manufacturer's technical mid-year changes. Hotchkis Performance products should only be installed by a qualified, licensed auto mechanic experienced in the installation of such products.

Warranty Claim Procedure:

The answer to ALL the following questions should be YES before making a warranty claim:

- Did you register the product at www.hotchkis.net or via the mail-in warranty card within 30 days of purchase?
- Is the product appropriate to your application?
- Did you carefully and thoroughly read the instructions provided along with the product?
- Do you have the original invoice or sales receipt?
- Is the return date within 36 months from the purchase date?
- Are you the original purchaser?
- Was the product properly installed by a qualified, licensed auto mechanic?
- Has the product been installed on the original vehicle on which it was installed at all times?
- Is the product unmodified and clean?
- Is the reason for return a legitimate product defect?

If the answer to all these questions is YES, please contact our Customer Service Department at (562) 907-7757. You will be given a Returned Goods Authorization Number (RGA) valid for 60 days. You will also be asked to ship the product prepaid to our facility. All shipments MUST be (i) prepaid, (ii) include the original invoice or sales receipt, (iii) show the RGA on the outside of the package and (iv) include your name, address, make and model of the vehicle, and a brief description of the claimed defect, including the circumstances under which the defect occurred. If the warranty claim is deemed valid then Hotchkis will estimate shipping costs to return the repaired or replacement part and contact you for payment. Hotchkis's Limited warranty requires that any repaired or replaced product will be returned to the sender excluding the cost of freight. Warranty related inquiries should be sent to the following address:

**HOTCHKIS PERFORMANCE, LLC
C/O CUSTOMER SERVICE
8633 Sorensen Avenue
SANTA FE SPRINGS, CA 90670**

Hotchkis Performance will not accept product returns without the RGA number, receipt and the information described above. C.O.D. or collect shipments will be refused. Once the returns are received at Hotchkis Performance, we will evaluate the products, verify the sales receipt, and investigate the warranty claim. Any repaired or replaced product will be returned to the sender.

Effective December 1, 2010. This return policy and limited warranty supersedes all previous policy and warranty statements. Policies and warranties are subject to change without notice. Hotchkis Performance is not responsible for printing errors.

IMPORTANT NOTICE

Ball Joint Info:

Before you install this product, please verify which front spindles you have. We have designed the upper a-arms to utilize the 73-87 style spindles. This type of spindle was widely used in disc brake conversions due to its easy interchangeability and readily available replacement parts (e.g. ball joints, tie rods). If you have original 71-72 style disc brake spindles, you can order ball joints from us to convert the Hotchkis upper a-arms to work with that spindle. (Part # **FA683**)

If you have 63-70 drum brake spindles, you will need to upgrade your spindles and brakes to take advantage of this a-arm kit. Please call if you would like to upgrade your spindles and brakes.

***UPPER A-ARMS
11390U
67 - 72 C-10 Pickup Truck***

*Thank you for your purchase from our new line of Chevy parts.
Please call us at 877 - 4NO - ROLL if you have any questions
regarding the service or installation of your Hotchkis Performance products.*

IMPORTANT: PLEASE READ THE ENTIRE INSTRUCTION MANUAL BEFORE STARTING THIS INSTALLATION. THIS KIT IS INTENDED FOR TRUCKS WITH 71-72 OR 73-87 DISC BRAKE SPINDLES. YOU MUST HAVE MECHANICAL KNOWLEDGE AND EXPERIENCE TO PERFORM THIS INSTALLATION. IF YOU ARE UNCERTAIN WITH THE PROCEDURE FOR THIS KIT PLEASE HAVE THE INSTALLATION PERFORMED BY A PROFESSIONAL TECHNICIAN.



Installation of Hotchkis Upper A-Arms

- 1 ***Raise the Truck***
Raise the vehicle by using a drive-on alignment rack. Securely block the rear wheels of the vehicle. You may also use jack stands to suspend the truck from the ground if a lift is not available. Raise the chassis so the front wheels are off the ground.



2 ***Remove Front Wheels***

Remove the front wheels from the vehicle.



3 ***Disconnect the Upper Ball Joint***

Remove the cotter pin from the upper ball joint stud. Use a wrench to loosen the castle nut that secures the upper ball joint to the spindle. Do not remove the castle nut entirely. Using a heavy hammer, hit the upper portion of the spindle to break loose the ball joint stud from the spindle. The weight of suspension and preload of the spring with the impact of the hammer should break loose the tapered press fit of the ball joint stud from the spindle. You may want to spray the stud area with penetrating oil if you're having a difficult time breaking it loose.

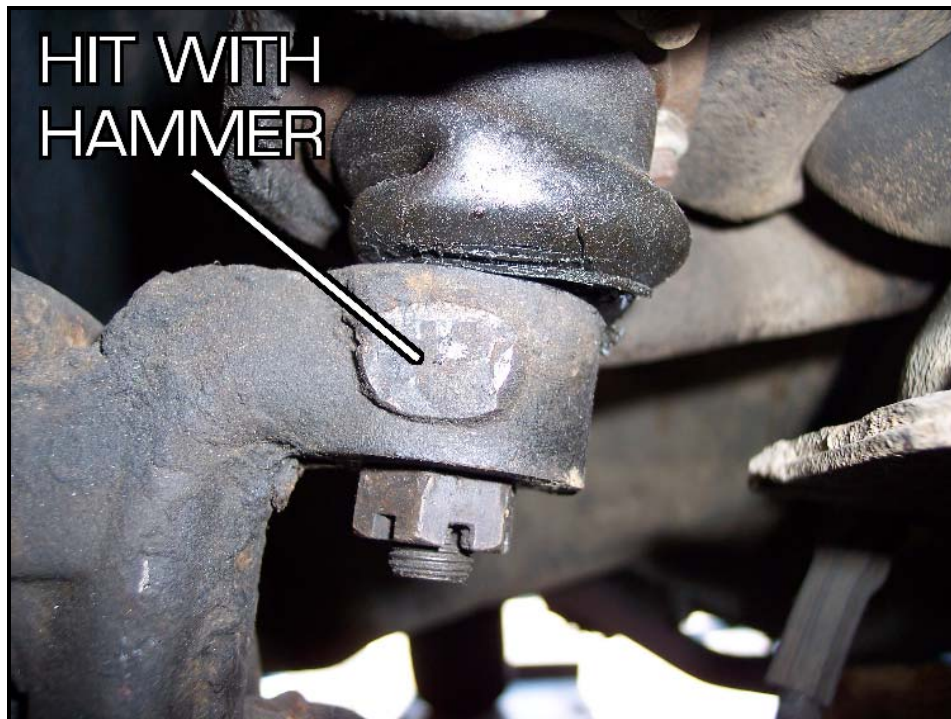

Once the ball joint is loose from the spindle, support the lower control arm with a floor jack and raise the suspension slightly to relieve the pressure on the castle nut. Remove the castle nut and lower the floor jack until the upper ball joint stud comes out of the spindle. You may want to use bungee cords to hold the spindle assembly close to the frame rails as to not stretch/damage the brake lines.

At this point, the only thing holding the upper a-arm to the car is the cross shaft. Undo the 2 nuts for each arm that secure the cross shaft to the chassis. The a-arms should be loose from the vehicle at this point.

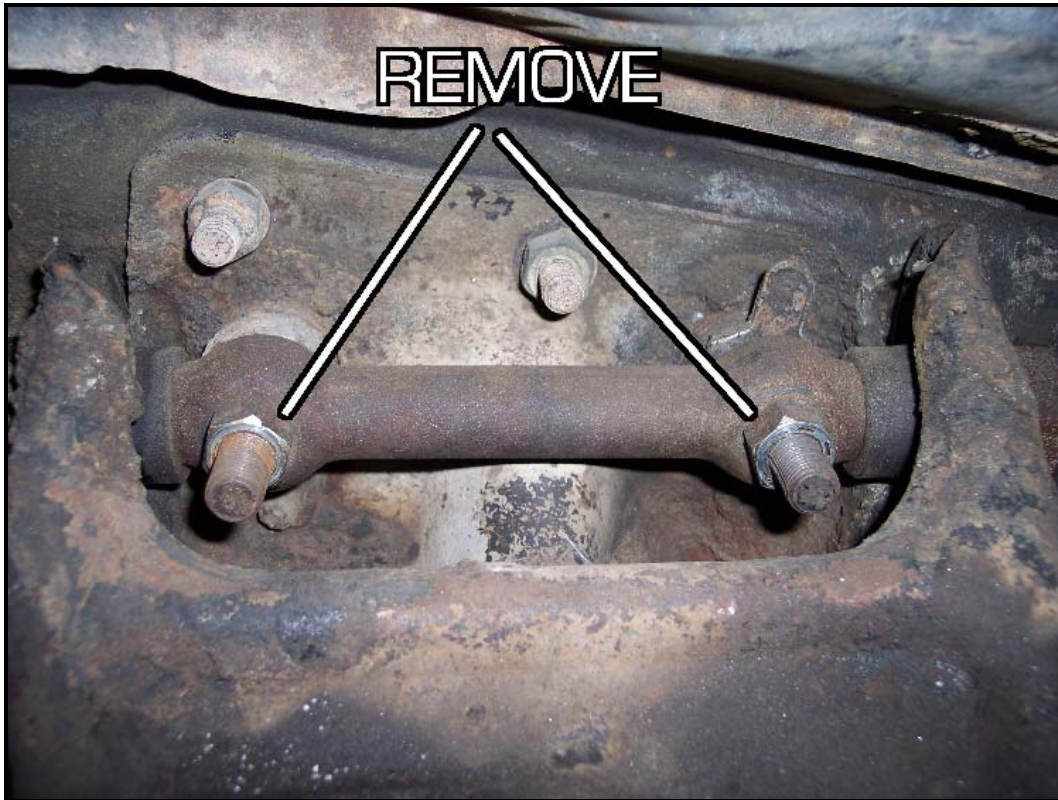

- 5 ***Reinstall the Hotchkis Upper A-arms***
Reinstall the Hotchkis a-arms in the same manner as removal. The a-arms are side specific, so please take caution when installing them. There are labels for “driver” and “passenger” located near the ball joints.

PASSENGER SIDE



DRIVER SIDE



Please also note the orientation of the cross shaft. The a-arms are designed to have the inner pivot lower than the stock location. This improves the camber gained for better front grip.



Install the cross shaft onto the vehicle first, using the same nuts that held in the stock arms.

Next, insert the ball joint stud into the spindle. You may need to raise the spindle using your floor jack once again. Spin the included castle nut on the stud and fully tighten. Make sure to line up the castle nut with the cotter pin hole. Insert the cotter pin and bend to lock.

Reinstall the wheels. You will need to perform a front end wheel alignment after this installation.

Check out our other great products for your C10 Pickup at Hotchkis.net

- 11390U Tubular Upper A-Arms (Improved Camber Curve)
- 11390L Tubular Lower A-Arms (Increased Caster for Stability and Cornering Grip)
- 18390 Rear Suspension Package (Quality rear shocks and longer/lower track bar for improved rear grip)
- 22390 Sway Bar Kit (Reduce Body Roll and Enhance Vehicle Response)
- 30390 Anti-Squat Kit (Increased anti-squat for better launches)
- 70390 Front Shock Kit (Re-positions front Bilstein shocks for more travel for lowered trucks)



Hotchkis Performance LLC
Return Policy & Limited Warranty



Effective December 1, 2010 all Hotchkis products must be registered to qualify for warranty at www.hotchkis.net or via the mail-in warranty card, included with the product, within 30 days of the original purchase date.

IMPORTANT: This warranty supersedes all other warranties included with this product.

Return Policy

We want you to be completely satisfied with your Hotchkis Performance product. For products, presenting signs of shipping damage please contact the freight carrier immediately. All our products are guaranteed to be free from manufacturer's defects. If your order arrives with a manufacture defect, please contact our Customer Service Department at (562) 907-7757. You will be assigned a Returned Goods Authorization Number (RGA). The package you return must show the RGA on the outside of the package, include the original invoice and be shipped prepaid to our facility. The product has to be unused and in its original packaging materials. Exchanges or refunds made after 30 days will be subject to a 20% restocking charge. **If you purchased your Hotchkis Performance product from an authorized dealer, you are still covered by this return policy. All returns however, should be made to your dealer, not to Hotchkis Performance directly.**

Limited Warranty

Hotchkis Performance offers a Limited Warranty against defects in materials and workmanship for the term of 36 months (3 years) from the date of purchase of this product. This Warranty only applies to the original retail purchaser who retains ownership of the vehicle on which the product was originally installed. If the product is determined to be defective, Hotchkis Performance will repair, replace or refund the purchase price of the defective product at Hotchkis Performance's sole discretion, which shall fully satisfy and discharge any and all warranty claims. Any repaired or replaced product will be returned to the sender excluding the cost of freight. **Products must be registered to qualify for warranty at www.hotchkis.net or via the mail-in warranty card, included with the product, within 30 days of the original purchase date.**

Exclusions from Warranty

Items offered but not manufactured by Hotchkis Performance are warranted according to the manufacturer's terms and are not covered by this limited warranty. Hotchkis Performance shall not be responsible for any labor, removal, installation, re-installation or maintenance costs. This warranty does not cover the cosmetic finish or plating of any product or any normal wear and tear to any product including, but not limited to bushings, brackets, end-links, hardware, steering components, shocks or springs. In addition, this warranty does not apply to any products that have been:

- Improperly installed or installed by someone other than a qualified, licensed auto mechanic experienced in the installation and removal of suspension products;
- Improperly serviced, misused, or modified, altered or subjected to abuse, negligence, accident or collision;
- Installed in any vehicle that has been modified;
- Installed on any vehicle that has carried loads in excess of automobile manufacturer suggested weight limits; or
- Installed on any vehicle that has been subject to abnormal or excessive use, including rallying, racing, or racing-type activities or off-road use.

Limitation of Warranty

This limited warranty is the entire and only warranty for the products and may not be modified or supplemented by any other person or company in any form. Any description of the products, by anyone, is for the sole purpose of identifying them and is not part of the basis of the bargain, and does not constitute a warranty that the products will conform to that description. The statements of any salesperson do not constitute part of this limited warranty and cannot be relied upon as a warranty.

THERE ARE NO WARRANTIES, EXPRESSED OR IMPLIED, INCLUDING ANY IMPLIED WARRANTIES OF MERCHANTABILITY OR FITNESS FOR A PARTICULAR PURPOSE, WHICH EXTEND BEYOND THE DESCRIPTION ON THE FACE HEREOF. ANY IMPLIED WARRANTIES ARE DISCLAIMED TO THE FULLEST EXTENT PERMITTED BY LAW. THIS WARRANTY DOES NOT COVER CONSEQUENTIAL DAMAGES, LOSS OF TIME OR REVENUES, INCONVENIENCE, LOSS

OF USE OF THE VEHICLE, DAMAGE TO THE VEHICLE OR COMPONENTS OF THE VEHICLE, ANY OTHER TYPE OF CONSEQUENTIAL DAMAGES, OR OTHER INCIDENTAL OR INDIRECT DAMAGES. HOTCHKIS' MAXIMUM LIABILITY UNDER THIS WARRANTY SHALL IN NO EVENT EXCEED THE



PURCHASE PRICE OF THE PRODUCT. Some states do not allow limitations on how long an implied warranty lasts or the exclusion or limitation of incidental or consequential damages and in such states the above limitations or exclusions may not apply. This limited warranty gives the purchaser specific legal rights and the purchaser may have other rights that may vary from state to state.

Technical Information

Hotchkis Performance makes every effort to ensure that you are provided with the most accurate and up-to-date technical information. However, all technical information is approximate and may vary upon application. Additional suspension components may be needed in some applications, depending upon the make, model, engine and chassis of the vehicle. Hotchkis Performance is not responsible for any consequences resulting from manufacturer's technical mid-year changes. Hotchkis Performance products should only be installed by a qualified, licensed auto mechanic experienced in the installation of such products.

Warranty Claim Procedure:

The answer to ALL the following questions should be YES before making a warranty claim:

- Did you register the product at www.hotchkis.net or via the mail-in warranty card within 30 days of purchase?
- Is the product appropriate to your application?
- Did you carefully and thoroughly read the instructions provided along with the product?
- Do you have the original invoice or sales receipt?
- Is the return date within 36 months from the purchase date?
- Are you the original purchaser?
- Was the product properly installed by a qualified, licensed auto mechanic?
- Has the product been installed on the original vehicle on which it was installed at all times?
- Is the product unmodified and clean?
- Is the reason for return a legitimate product defect?

If the answer to all these questions is YES, please contact our Customer Service Department at (562) 907-7757. You will be given a Returned Goods Authorization Number (RGA) valid for 60 days. You will also be asked to ship the product prepaid to our facility. All shipments MUST be (i) prepaid, (ii) include the original invoice or sales receipt, (iii) show the RGA on the outside of the package and (iv) include your name, address, make and model of the vehicle, and a brief description of the claimed defect, including the circumstances under which the defect occurred. If the warranty claim is deemed valid then Hotchkis will estimate shipping costs to return the repaired or replacement part and contact you for payment. Hotchkis's Limited warranty requires that any repaired or replaced product will be returned to the sender excluding the cost of freight. Warranty related inquiries should be sent to the following address:

**HOTCHKIS PERFORMANCE, LLC
C/O CUSTOMER SERVICE
8633 Sorensen Avenue
SANTA FE SPRINGS, CA 90670**

Hotchkis Performance will not accept product returns without the RGA number, receipt and the information described above. C.O.D. or collect shipments will be refused. Once the returns are received at Hotchkis Performance, we will evaluate the products, verify the sales receipt, and investigate the warranty claim. Any repaired or replaced product will be returned to the sender.

Effective December 1, 2010. This return policy and limited warranty supersedes all previous policy and warranty statements. Policies and warranties are subject to change without notice. Hotchkis Performance is not responsible for printing errors.

***Rear Suspension System
18390
67-72 C-10 Pickup Truck***

*Thank you for your purchase from our new line of Chevy parts.
Please call us at 877 - 4NO - ROLL if you have any questions
regarding the service or installation of your Hotchkis Performance products.*

**IMPORTANT: PLEASE READ THE ENTIRE INSTRUCTION MANUAL BEFORE
STARTING THIS INSTALLATION. THIS KIT IS INTENDED FOR TRUCKS NO LOWER
THAN A 6" REAR DROP. THE USE OF LOWERING BLOCKS IN CONJUNCTION
WITH A 6" REAR DROP IS AN ACCEPTABLE MEANS OF LOWERING THE REAR PAST 6".
BE SURE TO HAVE THE REAR FRAME C-NOTCHED FOR DROPS LOWER THAN 6".**



Installation of Hotchkis Rear Shocks

1 ***Raise the Truck***

Raise the vehicle by using a drive-on alignment rack. Securely block the front wheels of the vehicle.



2 ***Remove Old Shocks***

Remove your old rear shocks by unfastening the top and bottom nuts & bolts. You may discard the shocks and hardware.

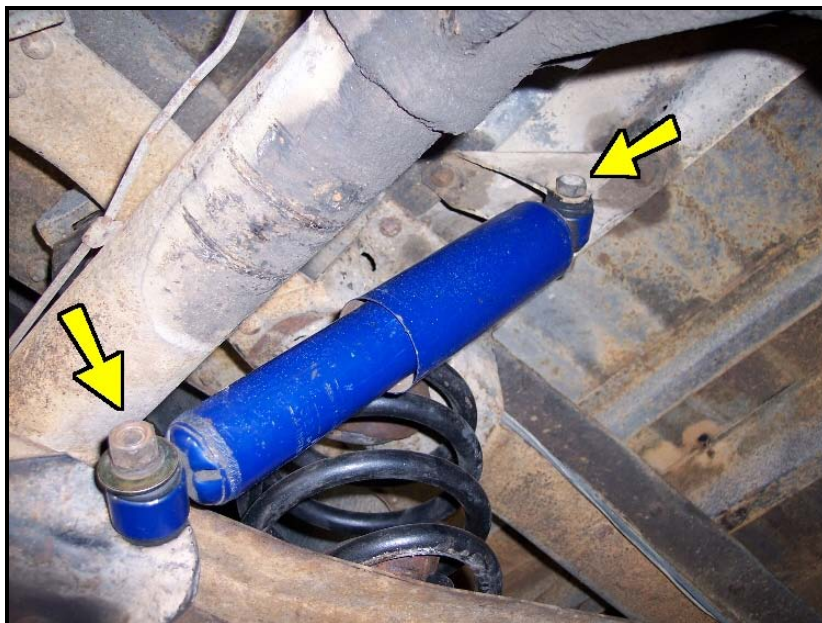

3 ***Support the Trailing arms***

Using the lifting jacks on your lift, support the rear trailing arms under the coil springs. Jack the truck up until the rear wheels just begin to raise off the lift surface.

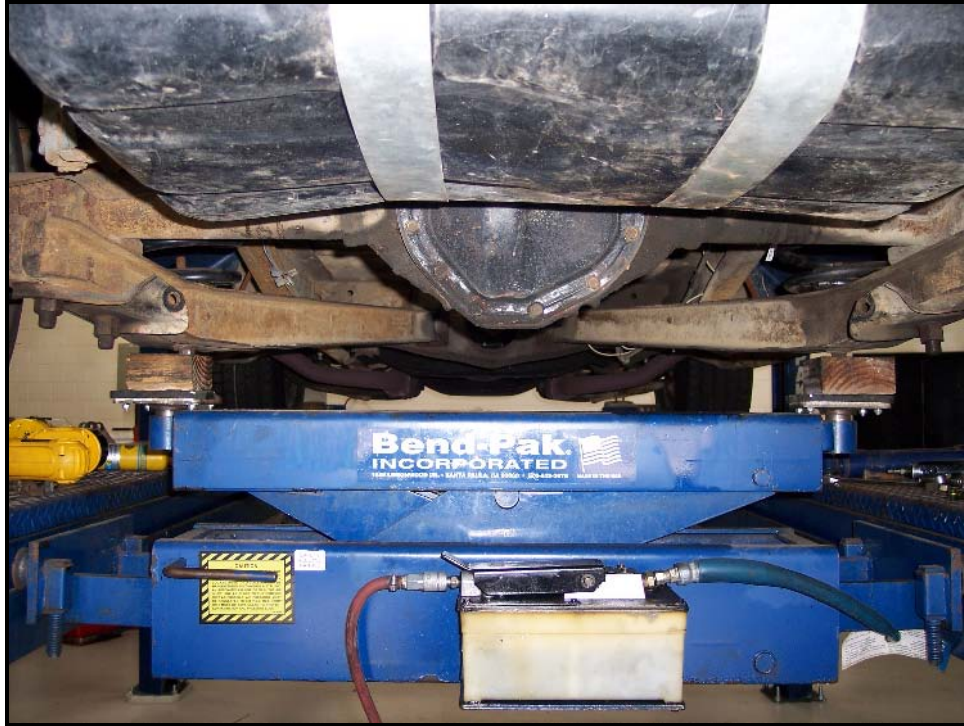

4 ***Remove Stock Shock Mounts***

Both the upper and lower shock mounts will be replaced. Using an air chisel, cut off the rivet heads securing the upper mount to the rear frame. Completely remove the rivets.





Next, remove the lower shock mounts by undoing the large u-bolts holding the rear axle to the trailing arms. The lower mounts should be loose from the arms. You may discard the upper and lower mounts.





5 ***Install Hotchkis Shock Mounts***

Install the Hotchkis upper shock mounts as shown in the picture. Hardware is provided for mounting to the existing rivet holes.



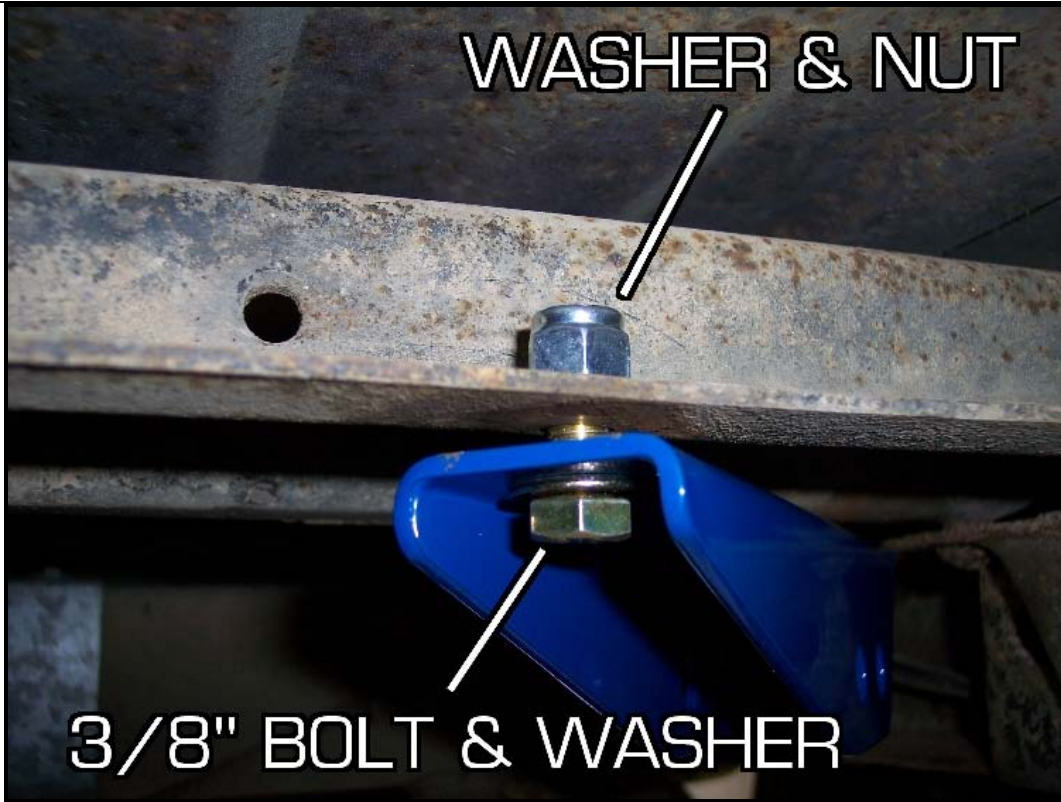

Install the lower shock mounts in the same manner as stock removal. Please see picture for proper orientation and placement of side specific brackets. Secure the lower shock mounts using the original u-bolt hardware. (Please call Hotchkis if you would like to purchase new U-bolts → P/N: T1734) Fully tighten hardware at this time. (Tip: It is recommended that you apply anti-seize compound on the U-bolt threads before reinstalling the nut.)

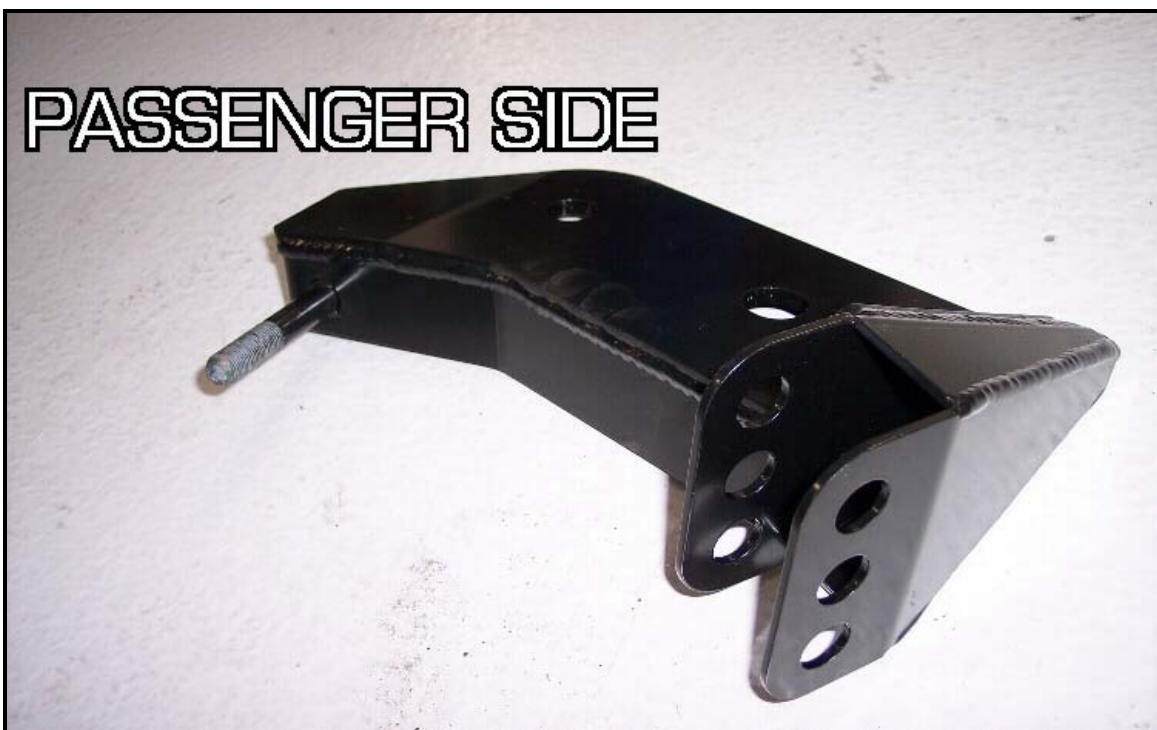



**REINSTALL U-BOLT
HARDWARE**

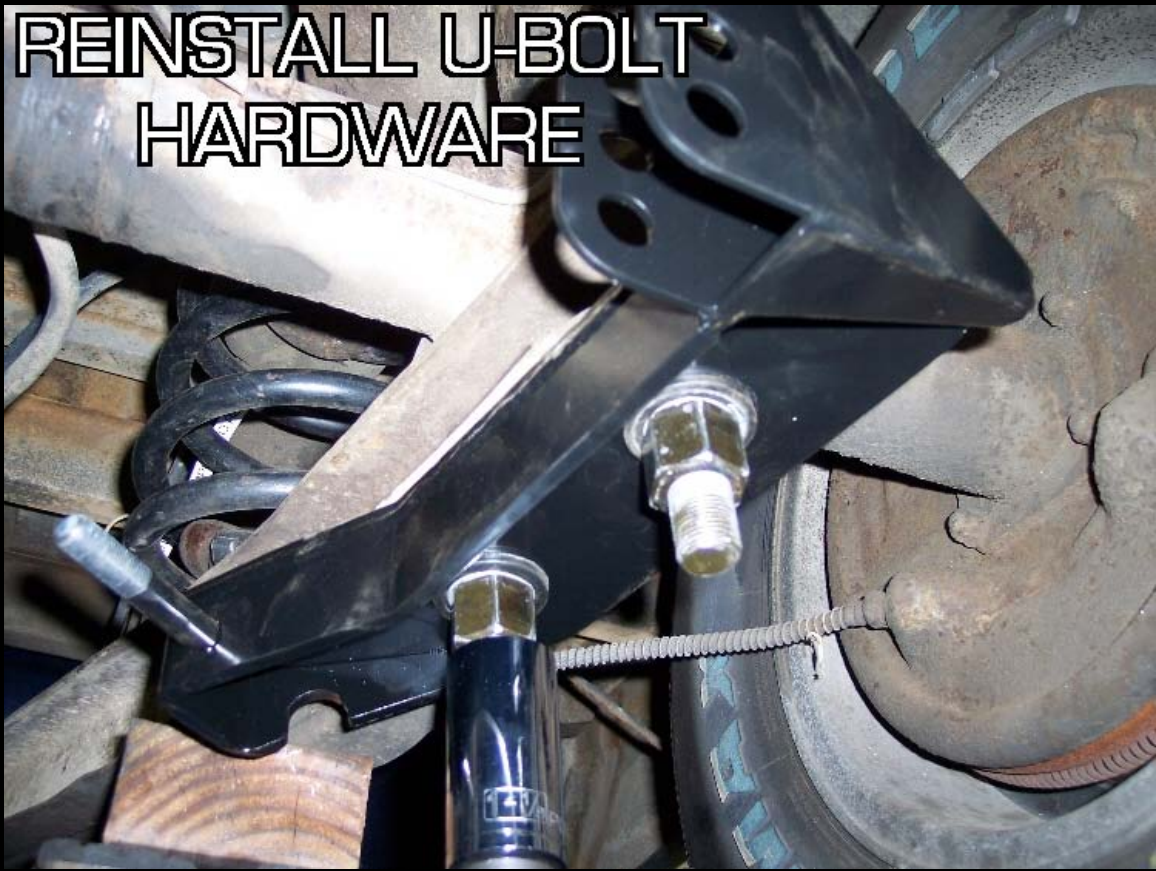

REPEAT ON DRIVER SIDE



6 **Install Hotchkis/Bilstein Shocks**

With the mounts in place, install the shocks by starting with the lower mount. Install the following hardware in the order shown in the picture. Leave this hardware loose until you get the upper mount in.



New hardware is also provided for the upper mount. The Hotchkis upper mount has 2 adjustment holes. The hole toward the rear is the stiffer shock setting. Once the shock is in place, fully tighten all shock hardware.

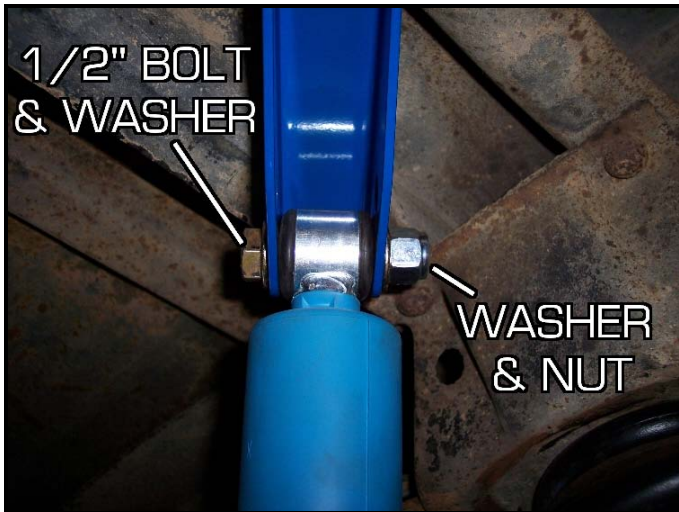

Lower the lifting jack from the trailing arms and you are now finished with the rear shock installation.

1 **Remove Stock Track Bar**

Remove the stock track bar by undoing the left frame mount bolt and the nut attaching the track bar to the rear end housing. Retain the frame mount hardware for reinstallation.

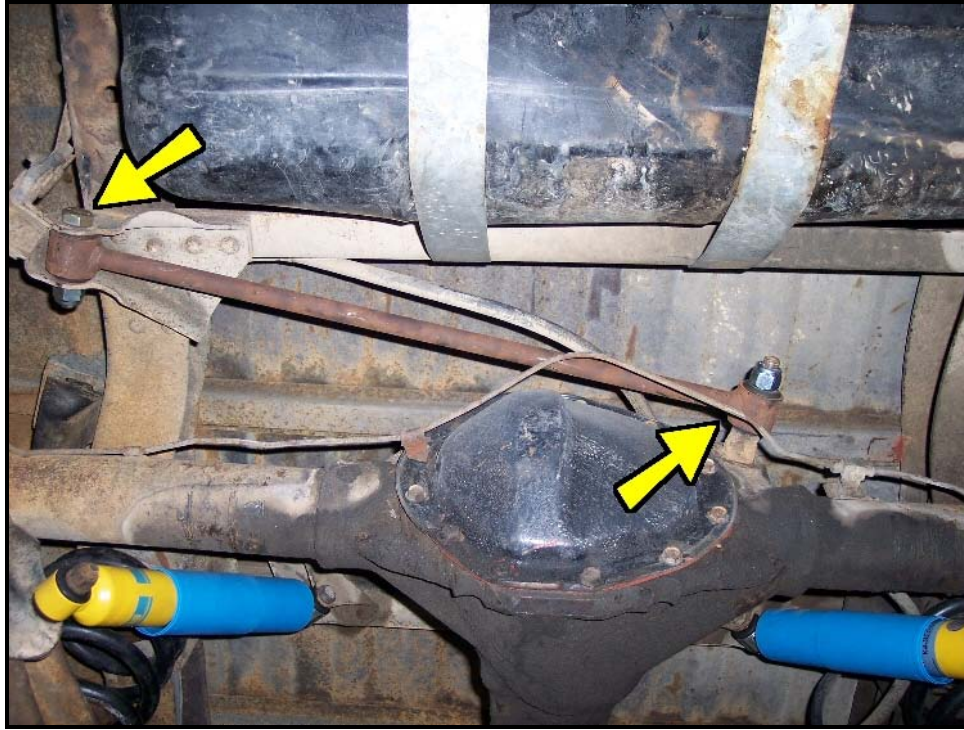

2 **Install Track Bar Mounts**

Grab the driver side track bar mount and install it on the existing frame mount. Use the original bolt and nut. Do not fully tighten this bolt yet.



Take the shorter adjustable bar and install it on the 2nd or 3rd hole on the driver side mount bracket. Grease bushing surface with provided lube.

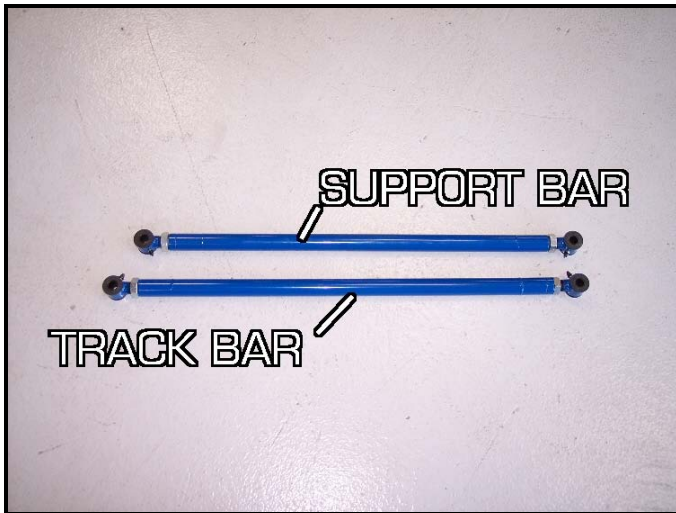

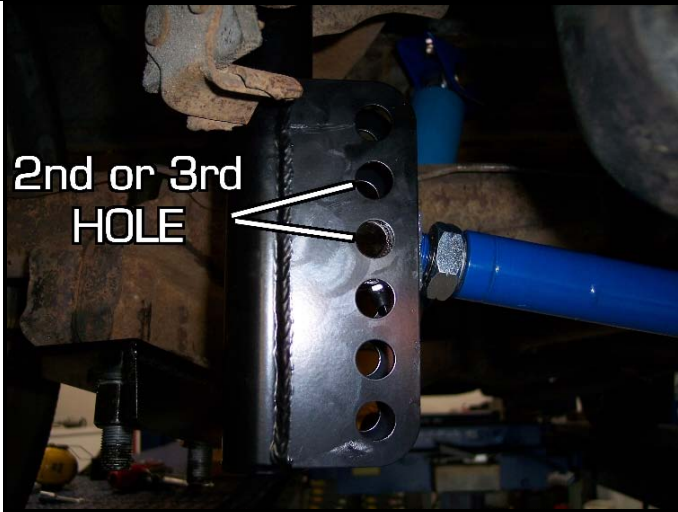

Attach the passenger side frame bracket to the bar using the included hardware.

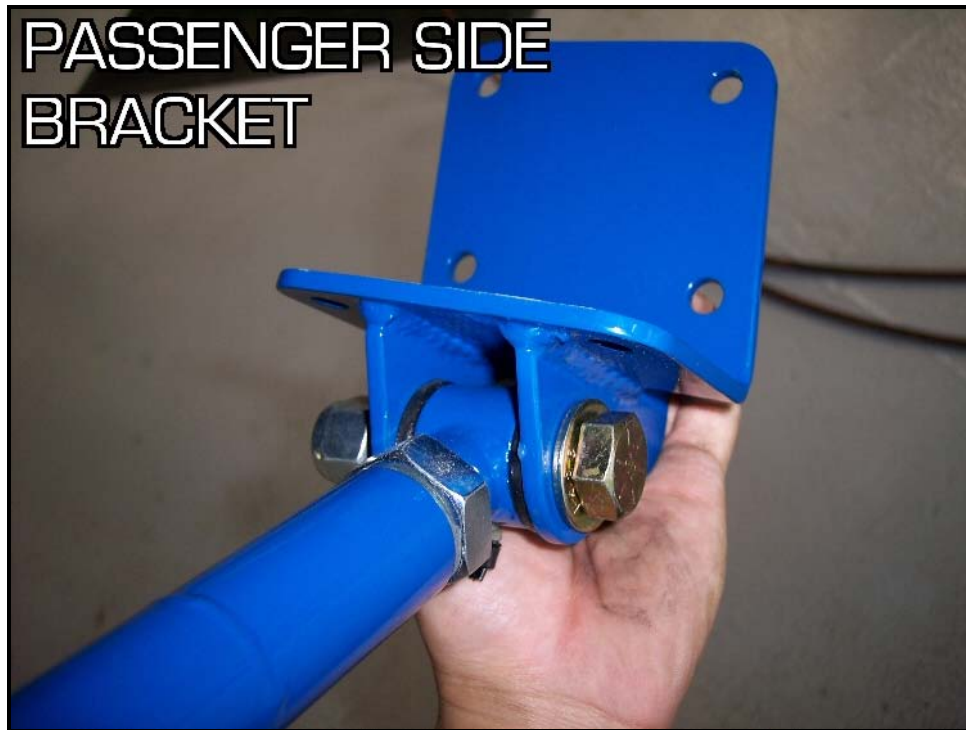

Adjust the length of the support bar so that the driver side bracket is vertical and the passenger side bracket mates to the frame rail properly.



Mark the passenger side frame rails to record all of the holes for the bracket.



(Important Note: Make sure the bracket is not too far towards the rear, which may cause the rearward bolts to interfere with the frame support. Frame support held in by rivets shown in above pictures.)

Drill the 6 holes using a 7/16" drill bit. (Tip: Drill pilot holes with a smaller 1/8" bit first) Watch out for any fuel lines inside the frame rail!

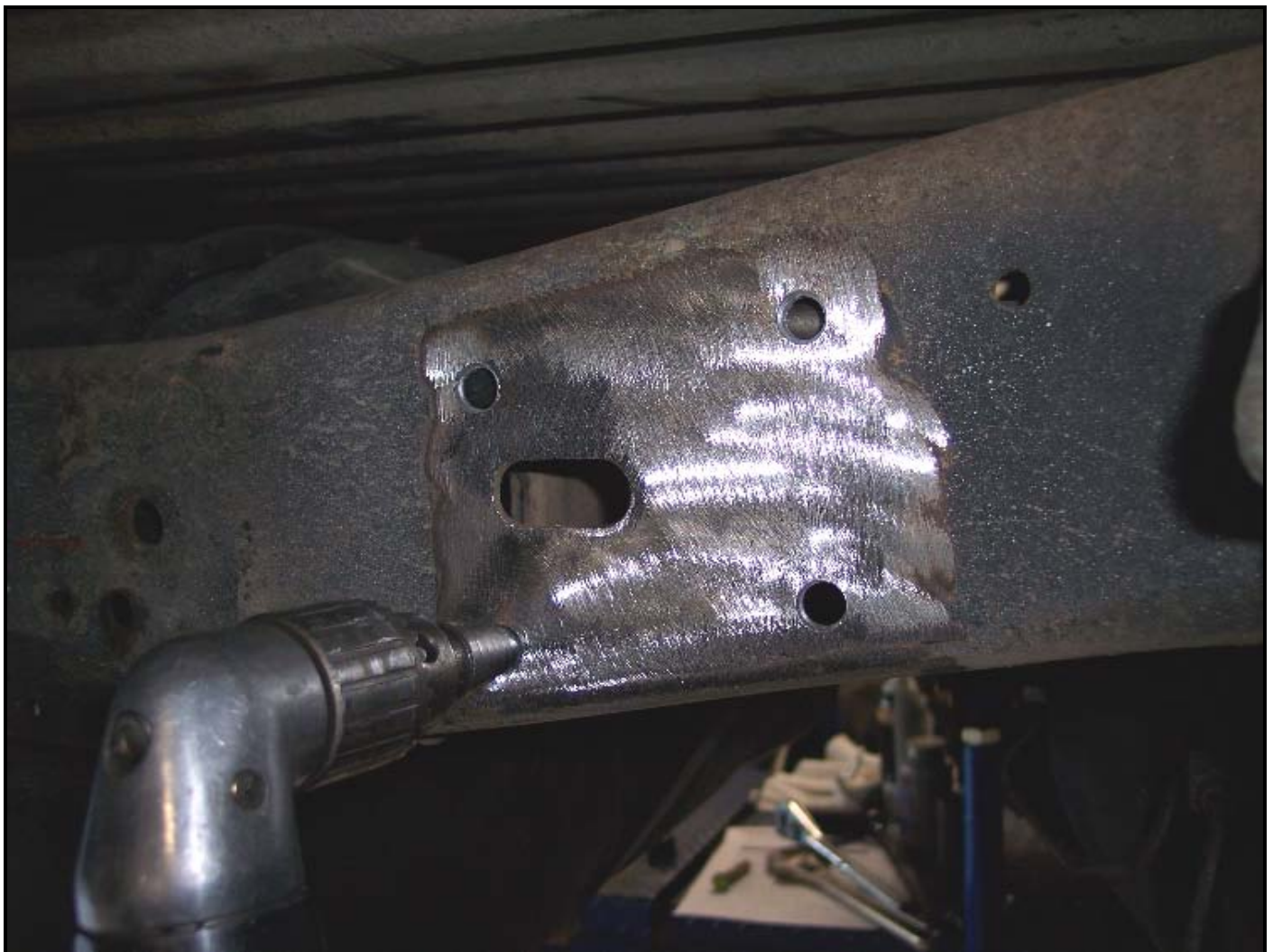

Once the holes are drilled, use the provided 3/8" hardware to mount the passenger side bracket to the frame. Fully tighten this hardware and the driver side hardware.

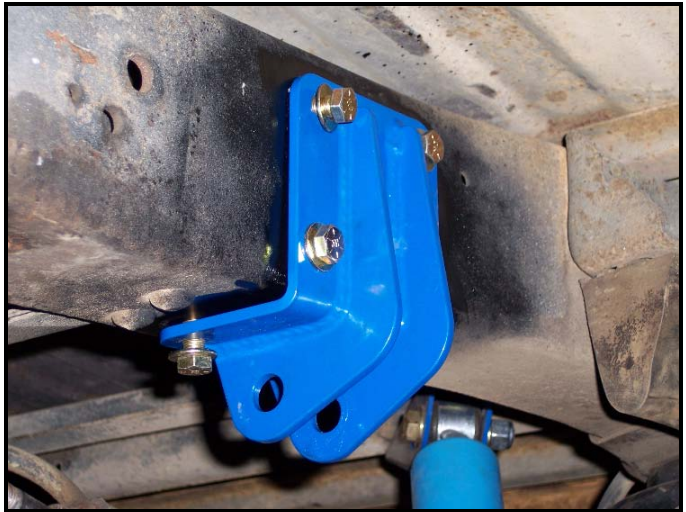

Next use the longer adjustable bar and mount it to the driver side frame bracket and the passenger side lower shock mount bracket. Choose the holes that allow the bar to be as low and as level as possible based on your ride height. You will need to adjust the length of the track bar to match the holes up. Again, apply the supplied grease to bushing surfaces.



Once all of the suspension members are in place, measure the distance between the inside of the rear tires and the wheel wells. Adjust the track bar (lower one) in or out to equalize the tire gap. Once adjusted, fully tighten all of the hardware.

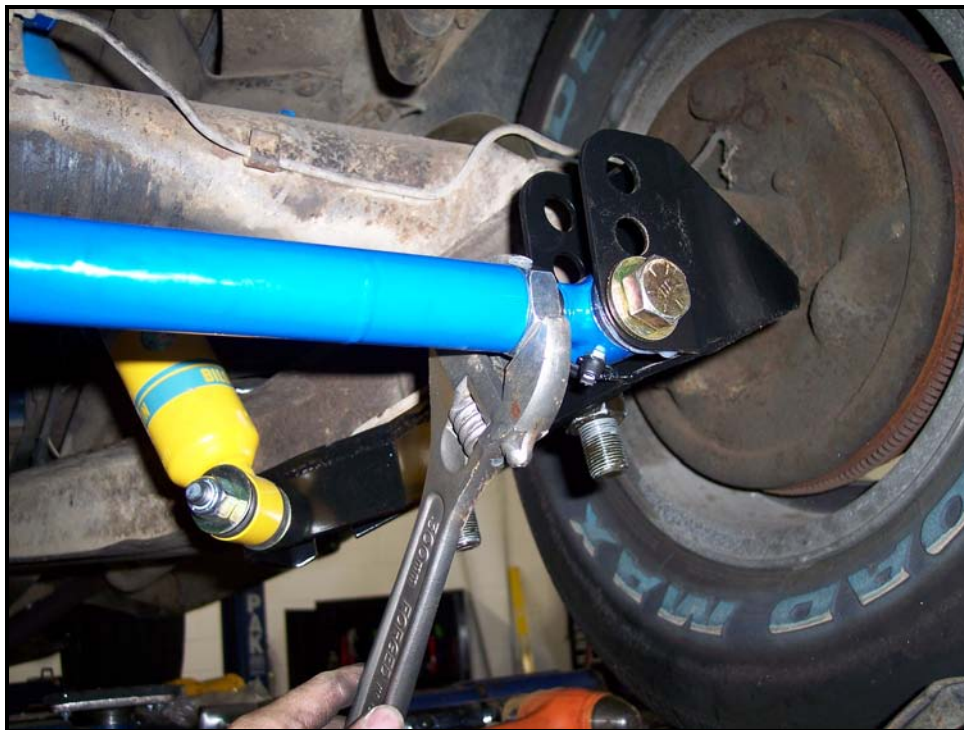

You are finished with the Hotchkis rear suspension system!



Check out our other great products for your C10 Pickup at Hotchkis.net

- 19390 Sport Coil Springs (4/6 Drop)
- 11390U Tubular Upper A-Arms (Better Camber Curve)
- 11390L Tubular Lower A-Arms (Increased Caster for Stability and Cornering Grip)
- 22390 Sway Bar Kit (Reduce Body Roll and Enhance Vehicle Response)
- 30390 Anti-Squat Kit (Increased anti-squat for better launches)
- 70390 Front Shock Kit (Re-positions front Bilstein shocks for more travel for lowered trucks)



Return Policy & Limited Warranty

Effective December 1, 2010 all Hotchkis products must be registered to qualify for warranty at www.hotchkis.net or via the mail-in warranty card, included with the product, within 30 days of the original purchase date.

IMPORTANT: This warranty supersedes all other warranties included with this product.

Return Policy

We want you to be completely satisfied with your Hotchkis Performance product. For products, presenting signs of shipping damage please contact the freight carrier immediately. All our products are guaranteed to be free from manufacturer's defects. If your order arrives with a manufacture defect, please contact our Customer Service Department at (562) 907-7757. You will be assigned a Returned Goods Authorization Number (RGA). The package you return must show the RGA on the outside of the package, include the original invoice and be shipped prepaid to our facility. The product has to be unused and in its original packaging materials. Exchanges or refunds made after 30 days will be subject to a 20% restocking charge. **If you purchased your Hotchkis Performance product from an authorized dealer, you are still covered by this return policy. All returns however, should be made to your dealer, not to Hotchkis Performance directly.**

Limited Warranty

Hotchkis Performance offers a Limited Warranty against defects in materials and workmanship for the term of 36 months (3 years) from the date of purchase of this product. This Warranty only applies to the original retail purchaser who retains ownership of the vehicle on which the product was originally installed. If the product is determined to be defective, Hotchkis Performance will repair, replace or refund the purchase price of the defective product at Hotchkis Performance's sole discretion, which shall fully satisfy and discharge any and all warranty claims. Any repaired or replaced product will be returned to the sender excluding the cost of freight. **Products must be registered to qualify for warranty at www.hotchkis.net or via the mail-in warranty card, included with the product, within 30 days of the original purchase date.**

Exclusions from Warranty

Items offered but not manufactured by Hotchkis Performance are warranted according to the manufacturer's terms and are not covered by this limited warranty. Hotchkis Performance shall not be responsible for any labor, removal, installation, re-installation or maintenance costs. This warranty does not cover the cosmetic finish or plating of any product or any normal wear and tear to any product including, but not limited to bushings, brackets, end-links, hardware, steering components, shocks or springs. In addition, this warranty does not apply to any products that have been:

- Improperly installed or installed by someone other than a qualified, licensed auto mechanic experienced in the installation and removal of suspension products;
- Improperly serviced, misused, or modified, altered or subjected to abuse, negligence, accident or collision;
- Installed in any vehicle that has been modified;
- Installed on any vehicle that has carried loads in excess of automobile manufacturer suggested weight limits; or
- Installed on any vehicle that has been subject to abnormal or excessive use, including rallying, racing, or racing-type activities or off-road use.

Limitation of Warranty

This limited warranty is the entire and only warranty for the products and may not be modified or supplemented by any other person or company in any form. Any description of the products, by anyone, is for the sole purpose of identifying them and is not part of the basis of the bargain, and does not constitute a warranty that the products will conform to that description. The statements of any salesperson do not constitute part of this limited warranty and cannot be relied upon as a warranty.

THERE ARE NO WARRANTIES, EXPRESSED OR IMPLIED, INCLUDING ANY IMPLIED WARRANTIES OF MERCHANTABILITY OR FITNESS FOR A PARTICULAR PURPOSE, WHICH EXTEND BEYOND THE DESCRIPTION ON THE FACE HEREOF. ANY IMPLIED WARRANTIES ARE DISCLAIMED TO THE FULLEST EXTENT PERMITTED BY LAW. THIS WARRANTY DOES NOT COVER CONSEQUENTIAL DAMAGES, LOSS OF TIME OR REVENUES, INCONVENIENCE, LOSS OF USE OF THE VEHICLE, DAMAGE TO THE VEHICLE OR COMPONENTS OF THE VEHICLE, ANY OTHER TYPE OF CONSEQUENTIAL DAMAGES, OR OTHER INCIDENTAL OR INDIRECT DAMAGES. HOTCHKIS'



MAXIMUM LIABILITY UNDER THIS WARRANTY SHALL IN NO EVENT EXCEED THE PURCHASE PRICE OF THE PRODUCT. Some states do not allow limitations on how long an implied warranty lasts or the exclusion or limitation of incidental or consequential damages and in such states the above limitations or exclusions may not apply. This limited warranty gives the purchaser specific legal rights and the purchaser may have other rights that may vary from state to state.

Technical Information

Hotchkis Performance makes every effort to ensure that you are provided with the most accurate and up-to-date technical information. However, all technical information is approximate and may vary upon application. Additional suspension components may be needed in some applications, depending upon the make, model, engine and chassis of the vehicle. Hotchkis Performance is not responsible for any consequences resulting from manufacturer's technical mid-year changes. Hotchkis Performance products should only be installed by a qualified, licensed auto mechanic experienced in the installation of such products.

Warranty Claim Procedure:

The answer to ALL the following questions should be YES before making a warranty claim:

- Did you register the product at www.hotchkis.net or via the mail-in warranty card within 30 days of purchase?
- Is the product appropriate to your application?
- Did you carefully and thoroughly read the instructions provided along with the product?
- Do you have the original invoice or sales receipt?
- Is the return date within 36 months from the purchase date?
- Are you the original purchaser?
- Was the product properly installed by a qualified, licensed auto mechanic?
- Has the product been installed on the original vehicle on which it was installed at all times?
- Is the product unmodified and clean?
- Is the reason for return a legitimate product defect?

If the answer to all these questions is YES, please contact our Customer Service Department at (562) 907-7757. You will be given a Returned Goods Authorization Number (RGA) valid for 60 days. You will also be asked to ship the product prepaid to our facility. All shipments MUST be (i) prepaid, (ii) include the original invoice or sales receipt, (iii) show the RGA on the outside of the package and (iv) include your name, address, make and model of the vehicle, and a brief description of the claimed defect, including the circumstances under which the defect occurred. If the warranty claim is deemed valid then Hotchkis will estimate shipping costs to return the repaired or replacement part and contact you for payment. Hotchkis's Limited warranty requires that any repaired or replaced product will be returned to the sender excluding the cost of freight. Warranty related inquiries should be sent to the following address:

**HOTCHKIS PERFORMANCE, LLC
C/O CUSTOMER SERVICE
8633 Sorensen Avenue
SANTA FE SPRINGS, CA 90670**

Hotchkis Performance will not accept product returns without the RGA number, receipt and the information described above. C.O.D. or collect shipments will be refused. Once the returns are received at Hotchkis Performance, we will evaluate the products, verify the sales receipt, and investigate the warranty claim. Any repaired or replaced product will be returned to the sender.

Effective December 1, 2010. This return policy and limited warranty supersedes all previous policy and warranty statements. Policies and warranties are subject to change without notice. Hotchkis Performance is not responsible for printing errors.

4/6 Coil Spring Kit 19390 67-72 C-10 Truck



*Thank you for your purchase from our new line of Chevy parts.
Please call us at 877 - 4NO - ROLL if you have any questions
regarding the service or installation of your Hotchkis Performance products.*

**IMPORTANT: PLEASE READ THE ENTIRE INSTRUCTION MANUAL BEFORE
STARTING THIS INSTALLATION.**

Installation of Front Coils

1F ***Raise Vehicle***

Raise the vehicle using a lift or floor jacks. Secure the vehicle with jack stands and/or use chocks for the rear wheels if applicable. Raise the front of the vehicle until the front wheels are off the ground.

2F ***Remove Wheels***

Remove the front wheels.

3F ***Remove Cotter Pins***

Our main objective is to detach the lower control from the spindles. In order to do that we will need to unfasten the lower ball joint castle nut. The first step in doing this is to remove the cotter pins using dikes or pliers.



4F ***Loosen Lower Ball Joint Castle Nut***

Once the cotter pin is out of the way, use a wrench to loosen the castle nut. DO NOT undo the castle nut completely. Just loosen the nut so there is 3-4 threads showing between the bottom of the nut and the spindle. This gap will allow you to break the taper loose without launching the lower control arm down and sending the spring airborne.

5F ***Disengage Ball Joint Taper***

The lower ball joint stud is tapered and seats inside the spindle mount. It will take a certain amount of impact to break this taper seat loose. Do so by using a large ball peen hammer and smack the spindle mount until the ball joint breaks loose. This may take quite a few tries, but it will eventually break loose. Spray penetrating oil on the stud/spindle mating surface to ease the process. Once the taper seat breaks loose you will hear the lower arm pop and the load from the spring is resting on the castle nut.

6F ***Support the lower arm and remove Nut***

Place a jack underneath the lower control arm and jack up to support the force from the spring. You should see the castle nut rise and you should be able to remove the nut by hand.

7F ***Remove the spring***

Slowly lower the jack which will swing the lower arm down and release the coil spring.

8F ***Install New Droop Stop***

The Hotchkis spring is a bit shorter in height compared to stock. This requires a taller droop stop to be installed on the upper a-arms to prevent the coil from disengaging from the mounting pocket during full droop. Undo the stock droop stop and replace it with the supplied Hotchkis droop stop.



9F ***Install Hotchkis Coils***

Install the coil spring in the same manner as stock removal. Make sure to clock and index the bottom coil in the lower control arm properly. You also want to make sure the upper coil is seated in the top pocket properly as well. If you have our Hotchkis Lower Control Arms (#11390L), make sure the upper coil is seated properly and the lower polyurethane isolator is clocked properly in the Hotchkis arm.

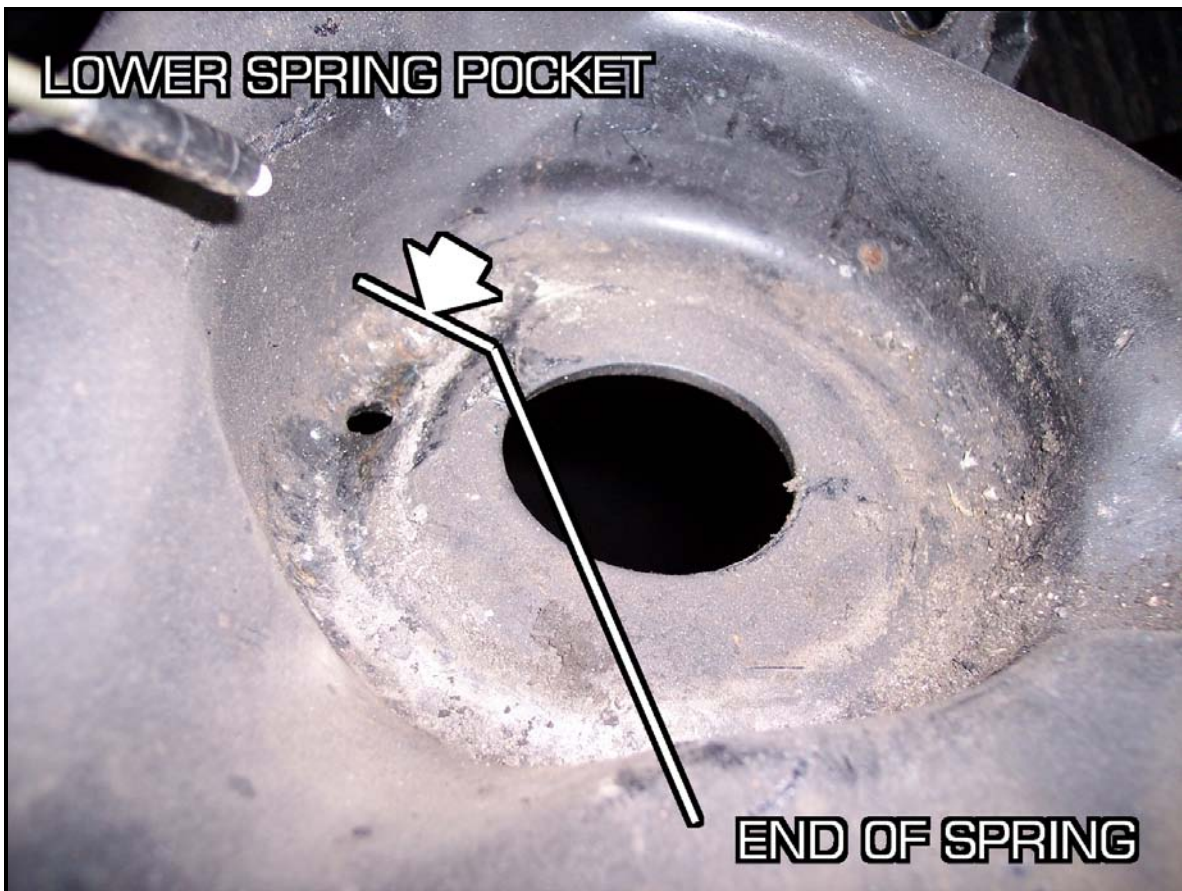

10F ***Reverse steps 3F to 7F***

Perform the same procedure in reverse order to finish installing the front springs.

Installation of Rear Coils

1R *Raising Car*

Raise the vehicle using a lift or floor jacks at the rear frame points. It is important that you do not jack up the truck from the rear end differential. Use chocks for the front wheels. Raise the rear of the vehicle until the rear wheels are barely touching the ground. It would be a good idea to place jack stands under the frame for safety.

2R *Disconnect Rear Shocks*

In order to get the springs out we must disconnect the rear shocks from the trailing arms (Truck Arms) to allow them to droop down enough. Disconnect the lower shock nut located on the truck arm bracket. You may need to play with the height of the floor jack to relieve any pulling load the rear end may have on the shocks. To relieve any load on the coils, raise the floor jack until the rear wheels are barely off the ground

3R *Remove Rear Spring*

Each spring has a top and bottom retainer. Undo the bolts that secure these retainers. The spring should be loose and free from the truck. Keep retainers for reinstallation.

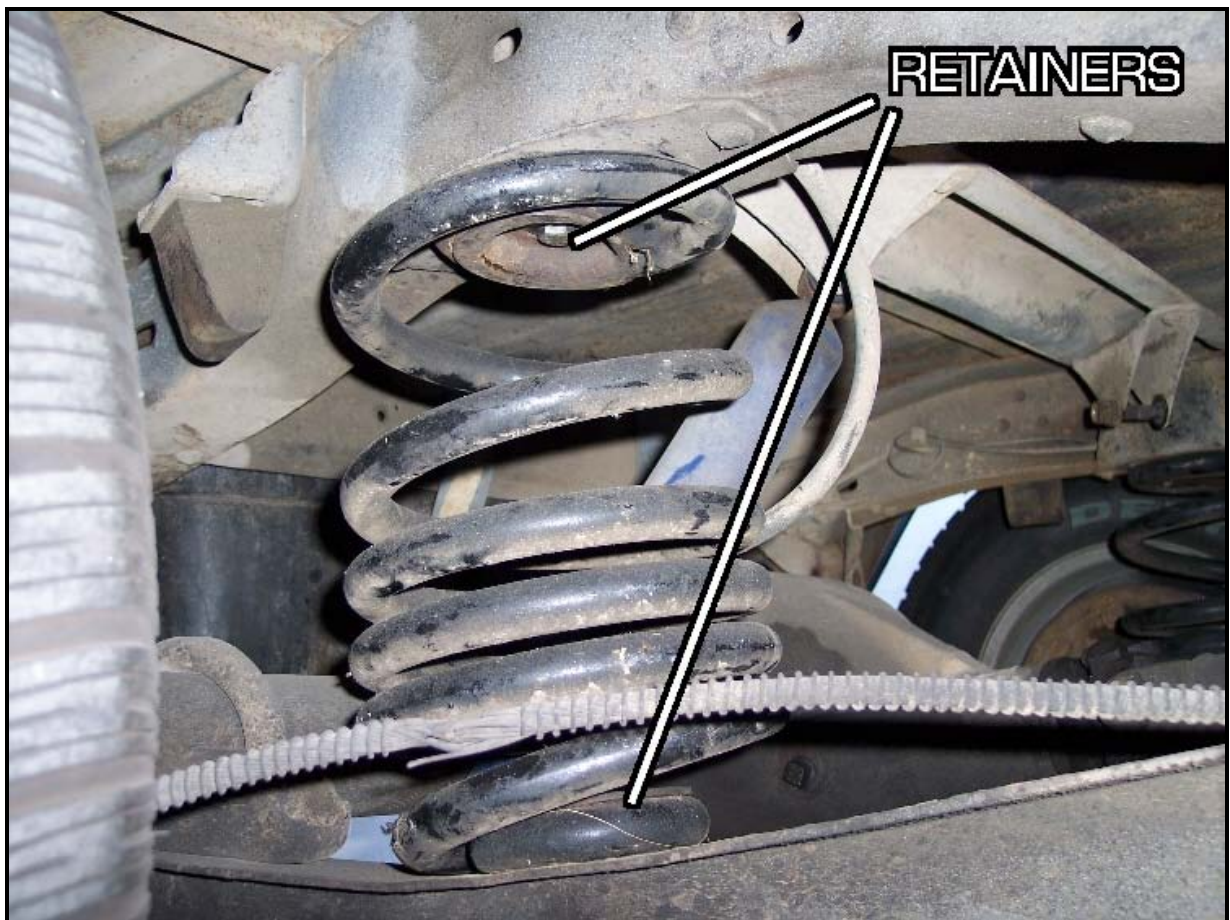

4R ***Install Hotchkis Rear Coils***

Install the coil spring in the same manner as stock removal. Your kit includes new hardware for the stock retainers. Always install the split lock washers on the nut side of the nut/bolt assembly.



5R ****Optional Spacers***

Your Hotchkis spring kit comes with optional spacers for the rear coils. If you are prone to having a load in the bed, then it may be beneficial to use these spacers. The kit has 4 spacers, each ¼" thick. Each spacer will raise the rear of the vehicle by ¼". You can use up to 2 spacers per side to give a total lift of ½". To install, Place the spacers between the coil spring and the truck arm during procedure step 4R.



***Check out our other great products for your C10 Pickup at
Hotchkis.net***

- 19390 Sport Coil Springs (4/6 Drop)
- 11390U Tubular Upper A-Arms (Improved Camber Curve)
- 11390L Tubular Lower A-Arms (Increased Caster for Stability and Cornering Grip)
- 18390 Rear Suspension Package (Quality rear shocks and longer/lower track bar for improved rear grip)
- 22390 Sway Bar Kit (Reduce Body Roll and Enhance Vehicle Response)
- 30390 Anti-Squat Kit (Increased anti-squat for better launches)
- 70390 Front Shock Kit (Re-positions front Bilstein shocks for more travel for lowered trucks)

Hotchkis Performance LLC Return Policy & Limited Warranty

Effective December 1, 2010 all Hotchkis products must be registered to qualify for warranty at www.hotchkis.net or via the mail-in warranty card, included with the product, within 30 days of the original purchase date.

IMPORTANT: This warranty supersedes all other warranties included with this product.

Return Policy

We want you to be completely satisfied with your Hotchkis Performance product. For products, presenting signs of shipping damage please contact the freight carrier immediately. All our products are guaranteed to be free from manufacturer's defects. If your order arrives with a manufacture defect, please contact our Customer Service Department at (562) 907-7757. You will be assigned a Returned Goods Authorization Number (RGA). The package you return must show the RGA on the outside of the package, include the original invoice and be shipped prepaid to our facility. The product has to be unused and in its original packaging materials. Exchanges or refunds made after 30 days will be subject to a 20% restocking charge. **If you purchased your Hotchkis Performance product from an authorized dealer, you are still covered by this return policy. All returns however, should be made to your dealer, not to Hotchkis Performance directly.**

Limited Warranty

Hotchkis Performance offers a Limited Warranty against defects in materials and workmanship for the term of 36 months (3 years) from the date of purchase of this product. This Warranty only applies to the original retail purchaser who retains ownership of the vehicle on which the product was originally installed. If the product is determined to be defective, Hotchkis Performance will repair, replace or refund the purchase price of the defective product at Hotchkis Performance's sole discretion, which shall fully satisfy and discharge any and all warranty claims. Any repaired or replaced product will be returned to the sender excluding the cost of freight. **Products must be registered to qualify for warranty at www.hotchkis.net or via the mail-in warranty card, included with the product, within 30 days of the original purchase date.**

Exclusions from Warranty

Items offered but not manufactured by Hotchkis Performance are warranted according to the manufacturer's terms and are not covered by this limited warranty. Hotchkis Performance shall not be responsible for any labor, removal, installation, re-installation or maintenance costs. This warranty does not cover the cosmetic finish or plating of any product or any normal wear and tear to any product including, but not limited to bushings, brackets, end-links, hardware, steering components, shocks or springs. In addition, this warranty does not apply to any products that have been:

- Improperly installed or installed by someone other than a qualified, licensed auto mechanic experienced in the installation and removal of suspension products;
- Improperly serviced, misused, or modified, altered or subjected to abuse, negligence, accident or collision;
- Installed in any vehicle that has been modified;
- Installed on any vehicle that has carried loads in excess of automobile manufacturer suggested weight limits; or
- Installed on any vehicle that has been subject to abnormal or excessive use, including rallying, racing, or racing-type activities or off-road use.

Limitation of Warranty

This limited warranty is the entire and only warranty for the products and may not be modified or supplemented by any other person or company in any form. Any description of the products, by anyone, is for the sole purpose of identifying them and is not part of the basis of the bargain, and does not constitute a warranty that the products will conform to that description. The statements of any salesperson do not constitute part of this limited warranty and cannot be relied upon as a warranty.

THERE ARE NO WARRANTIES, EXPRESSED OR IMPLIED, INCLUDING ANY IMPLIED WARRANTIES OF MERCHANTABILITY OR FITNESS FOR A PARTICULAR PURPOSE, WHICH EXTEND BEYOND THE DESCRIPTION ON THE FACE HEREOF. ANY IMPLIED WARRANTIES ARE DISCLAIMED TO THE FULLEST EXTENT PERMITTED BY LAW. THIS WARRANTY DOES NOT COVER CONSEQUENTIAL DAMAGES, LOSS OF TIME OR REVENUES, INCONVENIENCE, LOSS OF USE OF THE VEHICLE, DAMAGE TO THE VEHICLE OR COMPONENTS OF THE VEHICLE, ANY OTHER TYPE OF



CONSEQUENTIAL DAMAGES, OR OTHER INCIDENTAL OR INDIRECT DAMAGES. HOTCHKIS' MAXIMUM LIABILITY UNDER THIS WARRANTY SHALL IN NO EVENT EXCEED THE PURCHASE PRICE OF THE PRODUCT. Some states do not allow limitations on how long an implied warranty lasts or the exclusion or limitation of incidental or consequential damages and in such states the above limitations or exclusions may not apply. This limited warranty gives the purchaser specific legal rights and the purchaser may have other rights that may vary from state to state.

Technical Information

Hotchkis Performance makes every effort to ensure that you are provided with the most accurate and up-to-date technical information. However, all technical information is approximate and may vary upon application. Additional suspension components may be needed in some applications, depending upon the make, model, engine and chassis of the vehicle. Hotchkis Performance is not responsible for any consequences resulting from manufacturer's technical mid-year changes. Hotchkis Performance products should only be installed by a qualified, licensed auto mechanic experienced in the installation of such products.

Warranty Claim Procedure:

The answer to ALL the following questions should be YES before making a warranty claim:

- Did you register the product at www.hotchkis.net or via the mail-in warranty card within 30 days of purchase?
- Is the product appropriate to your application?
- Did you carefully and thoroughly read the instructions provided along with the product?
- Do you have the original invoice or sales receipt?
- Is the return date within 36 months from the purchase date?
- Are you the original purchaser?
- Was the product properly installed by a qualified, licensed auto mechanic?
- Has the product been installed on the original vehicle on which it was installed at all times?
- Is the product unmodified and clean?
- Is the reason for return a legitimate product defect?

If the answer to all these questions is YES, please contact our Customer Service Department at (562) 907-7757. You will be given a Returned Goods Authorization Number (RGA) valid for 60 days. You will also be asked to ship the product prepaid to our facility. All shipments MUST be (i) prepaid, (ii) include the original invoice or sales receipt, (iii) show the RGA on the outside of the package and (iv) include your name, address, make and model of the vehicle, and a brief description of the claimed defect, including the circumstances under which the defect occurred. If the warranty claim is deemed valid then Hotchkis will estimate shipping costs to return the repaired or replacement part and contact you for payment. Hotchkis's Limited warranty requires that any repaired or replaced product will be returned to the sender excluding the cost of freight. Warranty related inquires should be sent to the following address:

**HOTCHKIS PERFORMANCE, LLC
C/O CUSTOMER SERVICE
8633 Sorensen Avenue
SANTA FE SPRINGS, CA 90670**

Hotchkis Performance will not accept product returns without the RGA number, receipt and the information described above. C.O.D. or collect shipments will be refused. Once the returns are received at Hotchkis Performance, we will evaluate the products, verify the sales receipt, and investigate the warranty claim. Any repaired or replaced product will be returned to the sender.

Effective December 1, 2010. This return policy and limited warranty supersedes all previous policy and warranty statements. Policies and warranties are subject to change without notice. Hotchkis Performance is not responsible for printing errors.

Sport Sway Bar Kit 22390 *67-72 C-10 Truck*

*Thank you for your purchase from our new line of Chevy parts.
Please call us at 877 - 4NO - ROLL if you have any questions
regarding the service or installation of your Hotchkis Performance products.*

**IMPORTANT: PLEASE READ THE ENTIRE INSTRUCTION MANUAL BEFORE
STARTING THIS INSTALLATION. THIS INSTALLATION DEPICTS A TRUCK THAT
DID NOT HAVE A SWAY BARS FROM FACTORY.**

1F ***Raising Vehicle***

Raise front of the vehicle by using a 4 post lift or drive-on ramps. Securely block the rear wheels of the vehicle. Do not remove the front wheels during installation. It is imperative that the vehicle is at ride height for this installation.



2F ***Install Frame Mounts***

First step is to install the frame mounts. The mounts utilize existing rivet holes in the frame. You will need to air chisel the rivets as shown below.

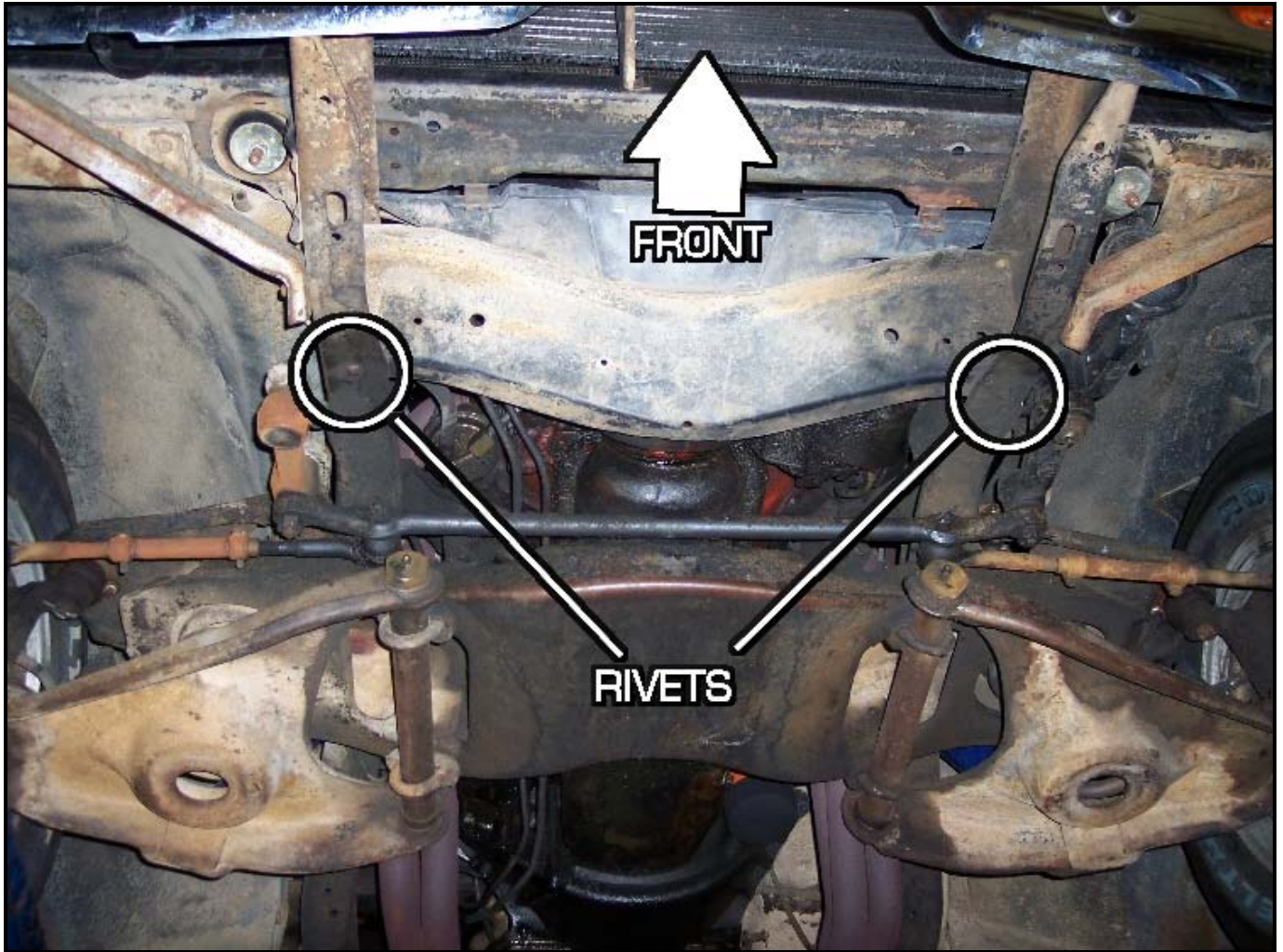

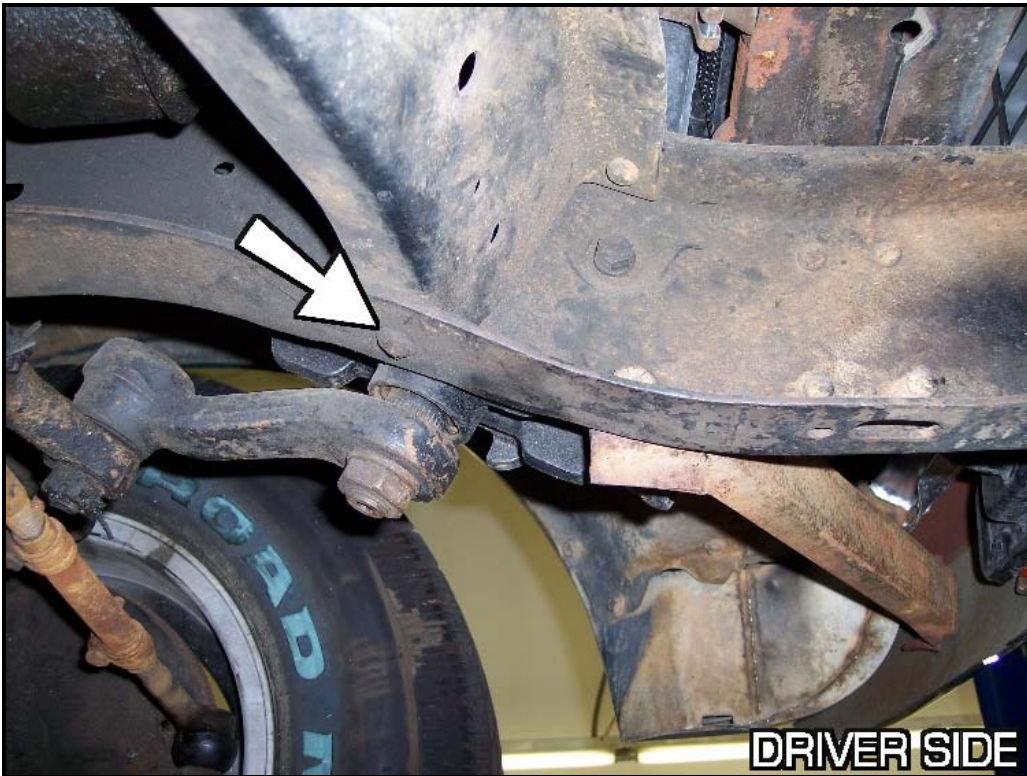



AIR CHISEL



HEAD CHISELED OFF

POP OUT THE REST OF THE RIVET WITH A POINTED CHISEL



RIVET REMOVED



Once the holes are clear, grab the 3/8" x 1.5" hex bolts & washers from the "front" hardware bag and insert them into the rivet holes facing down.



Position the mounting bracket to the frame rail and begin fastening the 3/8" bolts with the provided washers and nylock nuts. Do not tighten all the way!



Grab the 3/8" x 1.25" hex bolts and drop them into the mount holes on the bracket itself. Don't forget to use washers.

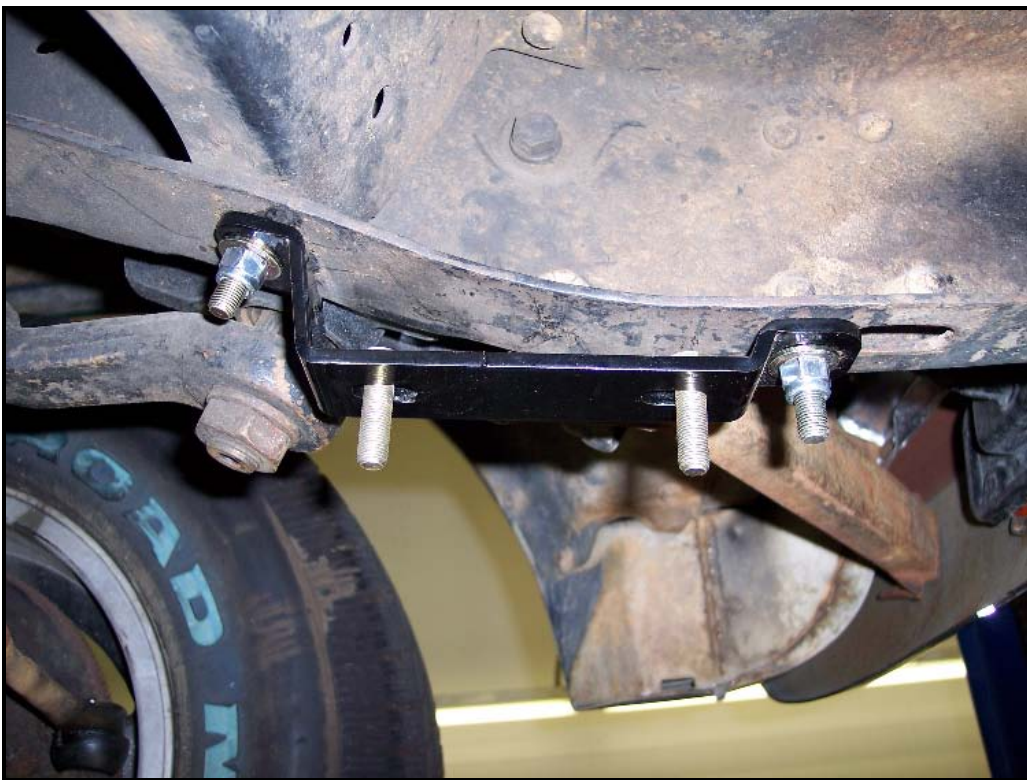

You can now fully tighten the frame bolts at this time.

3F ***Install Bushings & Brackets***

Next grease the inner surface of the provided polyurethane bushings and install them onto the sway bar near to the bends.



Slide the bushing brackets onto the bushings as shown below.



4F ***Mount Bar onto Truck***

Position the sway bar up to the frame mounts. Using the 3/8" hardware from the kit, start fastening the bushing brackets onto the frame mounts. Do not fully tighten these yet.

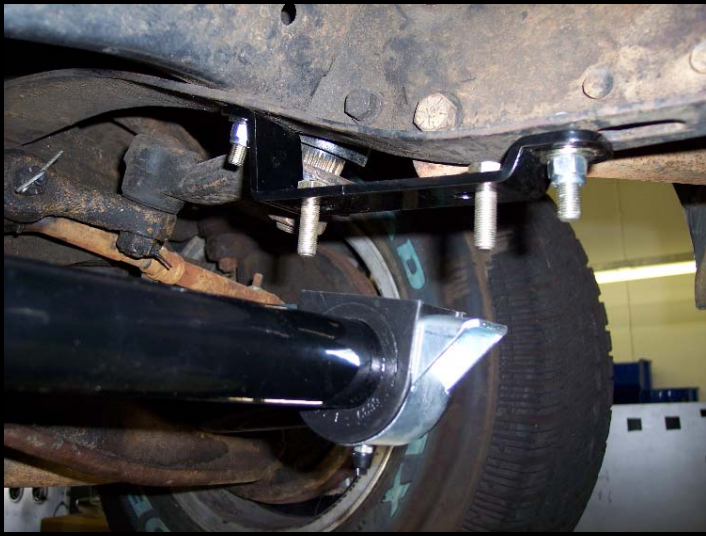

5F ***Install End Links***

The front lower a-arms have an existing hole that the sway bar end links will utilize.

First open up the 25108 end link kit. Grab the long bolt along with a large washer and bushing. Insert the bolt/washer/bushing into the sway bar hole from the top.



Next install additional large washers & bushings in the order shown below.



Insert the bolt through the a-arm and install the smaller diameter bushing and a small washer from the bottom of the arm. Tighten everything with the included nylock nut.



6F ***Finish Up***

Finish the installation by fully tightening the bushing bracket bolts. Double check all hardware for tightness and you are done with the front.



Installation of Hotchkis Rear Sway Bar

1R **Raising Car**

Raise rear of the vehicle by using a 4 post lift or drive-on ramps. Securely block the front wheels of the vehicle. Do not remove the rear wheels during installation. It is imperative that the vehicle is at ride height for this installation.



2R **Drill holes for Bushing Bracket**

We need to mount the bushing brackets onto the frame rails under the bed. Each bracket uses 2 holes for mounting. One of these holes is an existing hole occupied by a rivet. The other hole will need to be drilled. First, locate the factory rivet along the top section of the frame rails.

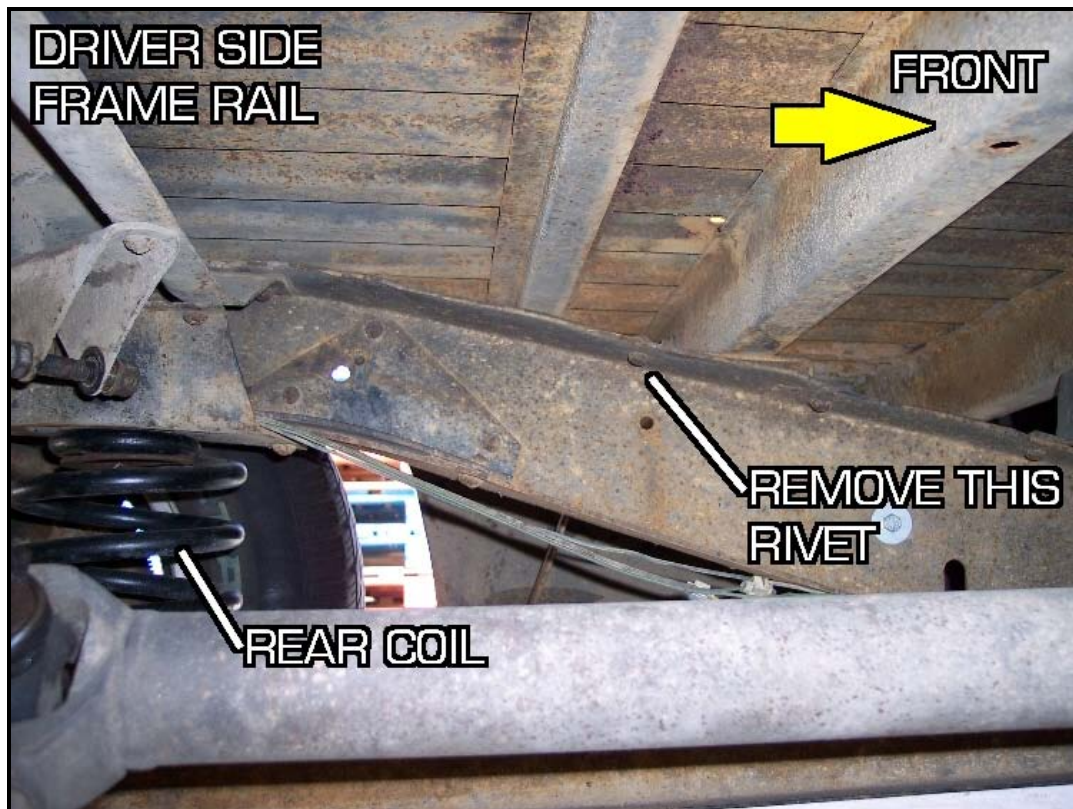

Use an air chisel to cut the head off and pop out the rivet with a punch. This hole will be your forward hole.

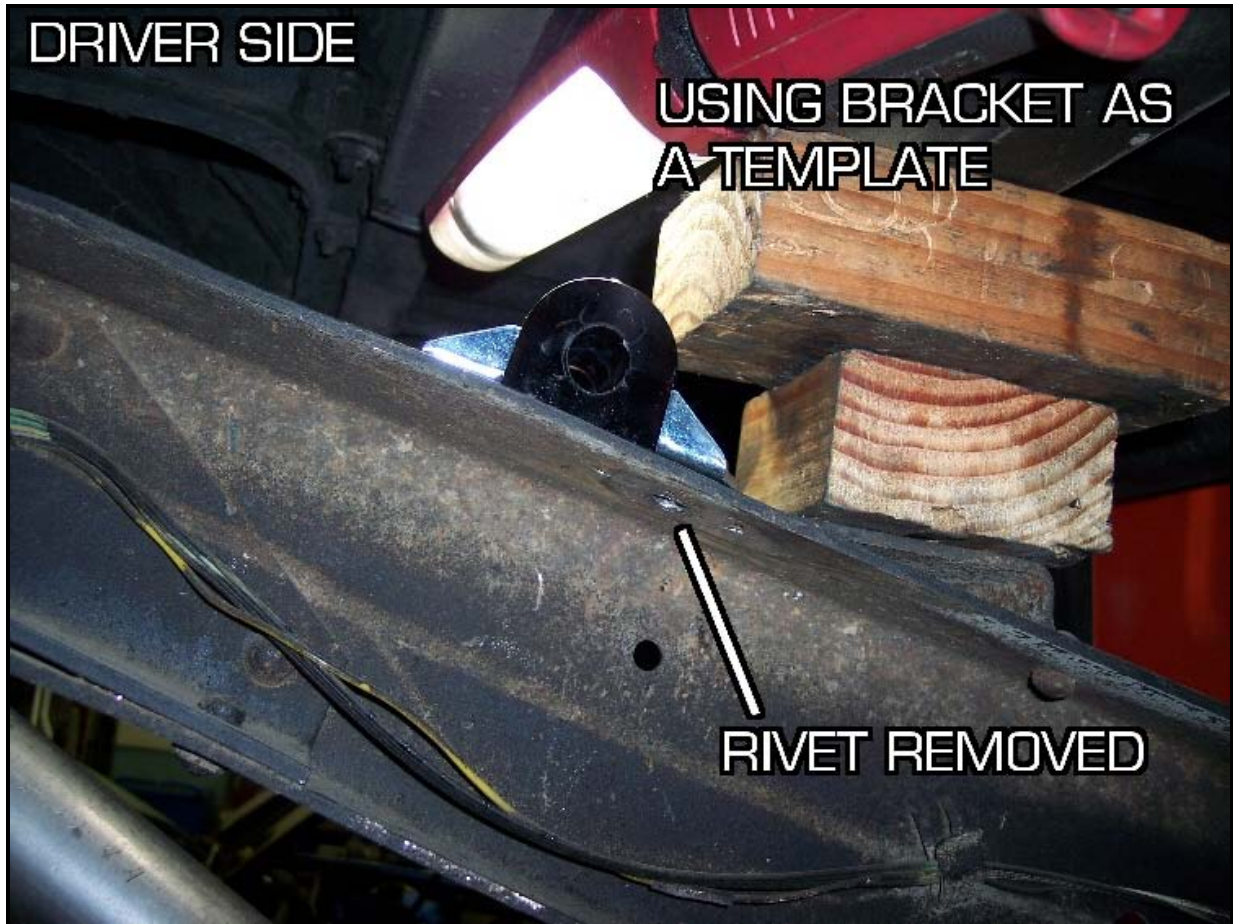

You will need to use the bushing bracket as a template to locate the rearward hole. Place the bracket over the rivet hole and mark the frame for the second hole. Using an 90° angle drill and a short 3/8" drill bit, drill the rearward hole. If you do not have a short enough drill bit or angle drill, you may need to raise the rear bed and drill from the top. (refer to your shop manual for disconnecting the bed) The bed would only need to be raised enough to fit your drill above. (NOTE: Pictures show the drilling down with the truck bed raised. The bushing and bracket does not mount to the top! This is only done to mark the hole location)



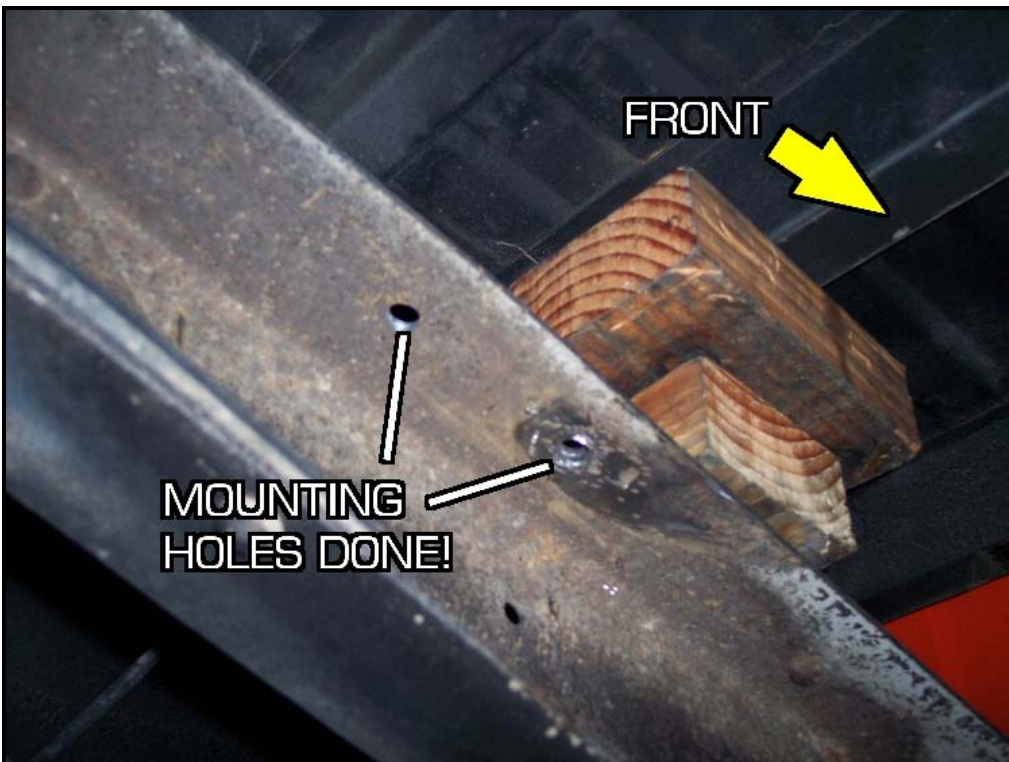

Once you have the 2 holes on each frame rail, we can install the sway bar, bushings and brackets. First, grease the inside surface of the D-shaped bushing. Install the bushings onto the sway bar ends. Next, install the bushing brackets onto the bushings.



Position the sway bar onto the truck as shown. The sway bar lever arms point towards the rear. Use the hardware from bag #17118-1 to mount the bushing bracket to the frame. The longer bolts (1.25") are for the front hole and the shorter bolts (1") mount the rear holes. Center the bracket so that the holes are in the middle of the bracket slots. Fully tighten the bolts.



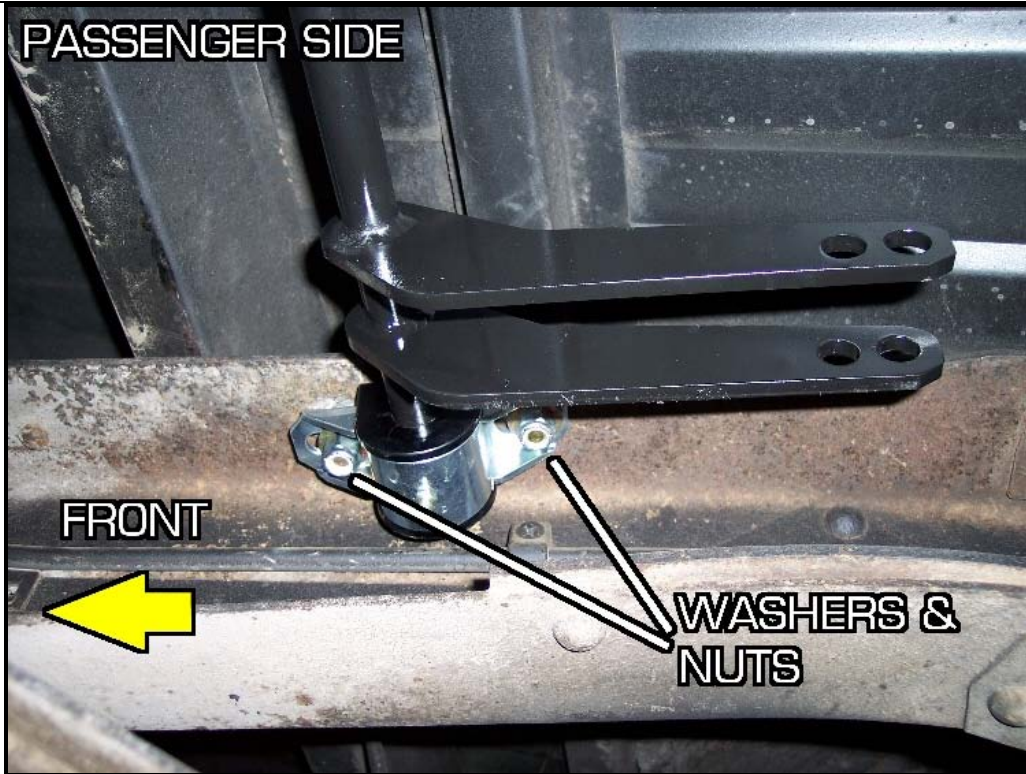

4R **Connect End Links**

Now that the bar is in place, we will attach the end links to the sway bar. Using bag#17118-2 hardware and included misalignment spacers, mount the end link rod ends to the sway bar lever arms. Use the center hole for now.

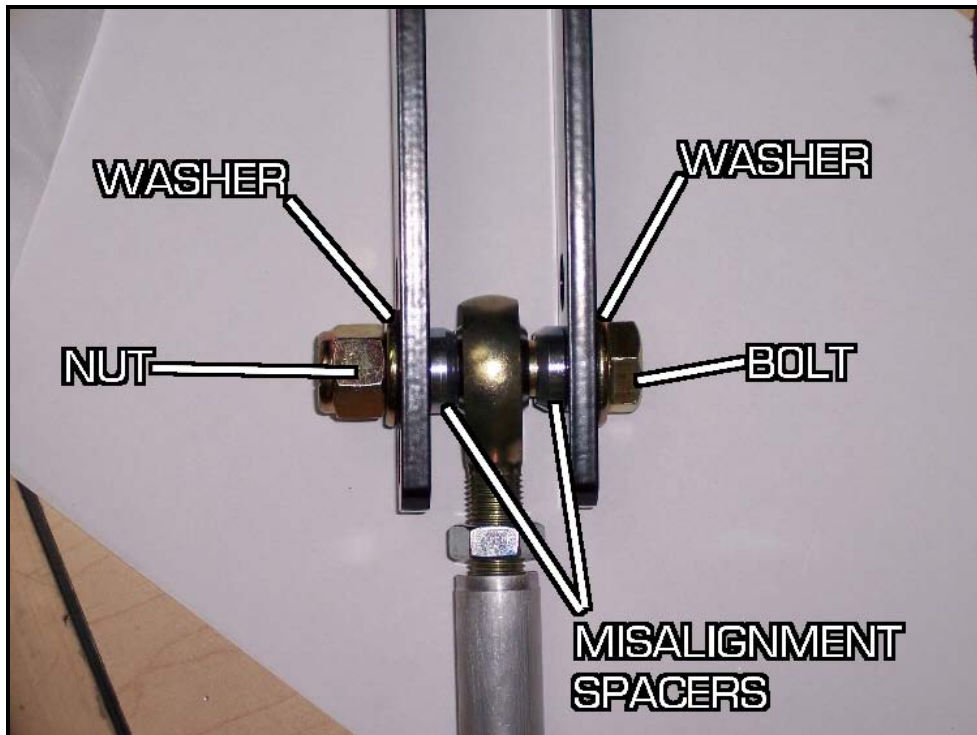

5R **Drill the Trailing Arm Mount Hole**

With the end links attached to the sway bar, adjust the length of the end links so that the sway bar lever arms are near level when the lower rod ends are in the center of the trailing arm. Also make sure the end links are vertical. Mark the hole center and drill the trailing arm with a 3/8" drill bit.

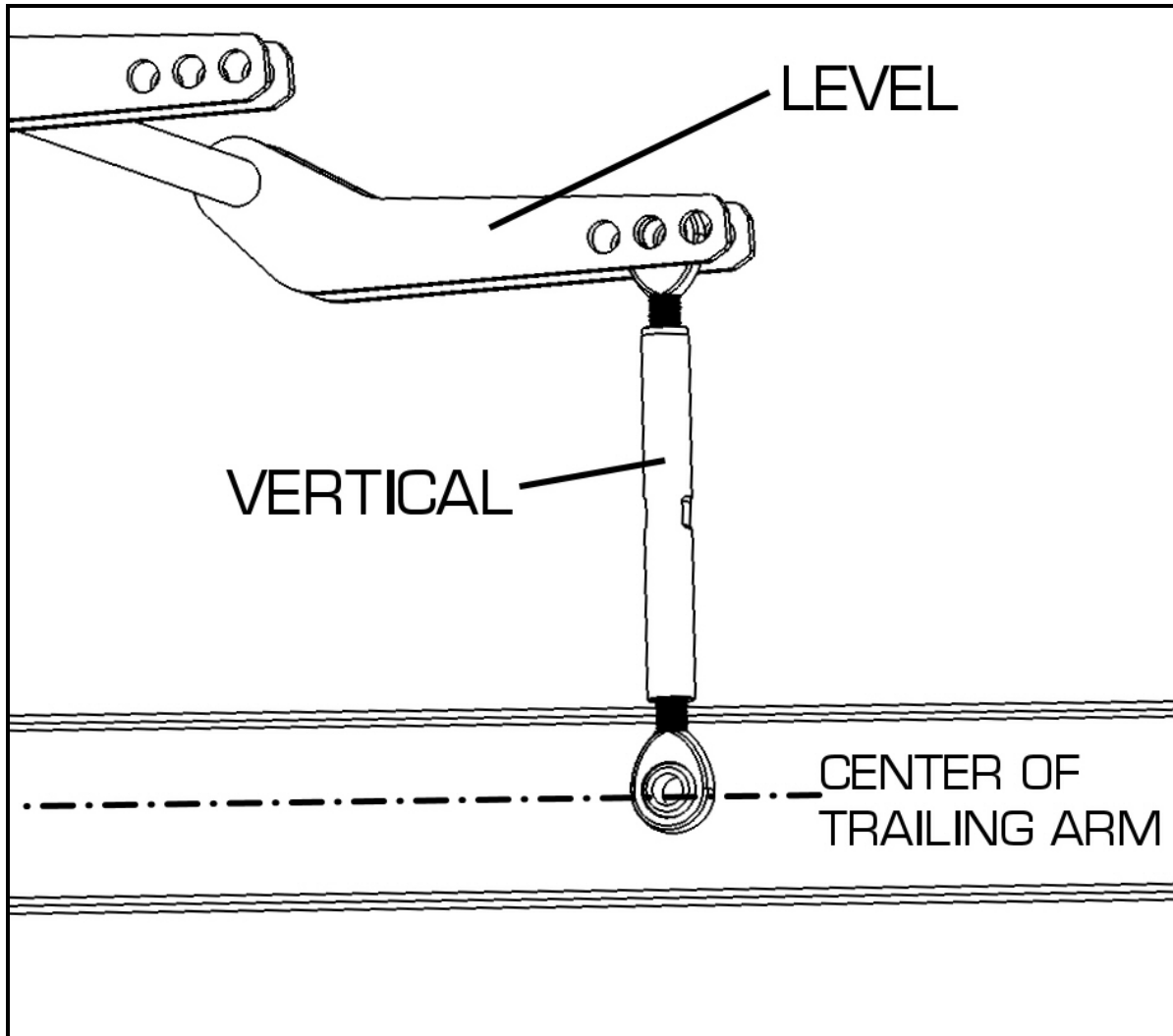



6R ***Weld Support Gusset***

Use hardware bag#17118-3 and mount the support gusset as shown in the picture. Grind away any rust, paint or dirt near the top and bottom of gusset. Stitch weld the top and bottom edges of the gusset to the trailing arm. Spray paint the gusset once you finished welding.





7R **Finish Mounting the End Link**

Use the rest of the hardware from bag#17118-3 to mount the lower end of the end link to the trailing arm as shown in the picture below. Fully tighten all hardware including the jam nuts on the links at this time. You are finished with the rear sway bar installation!

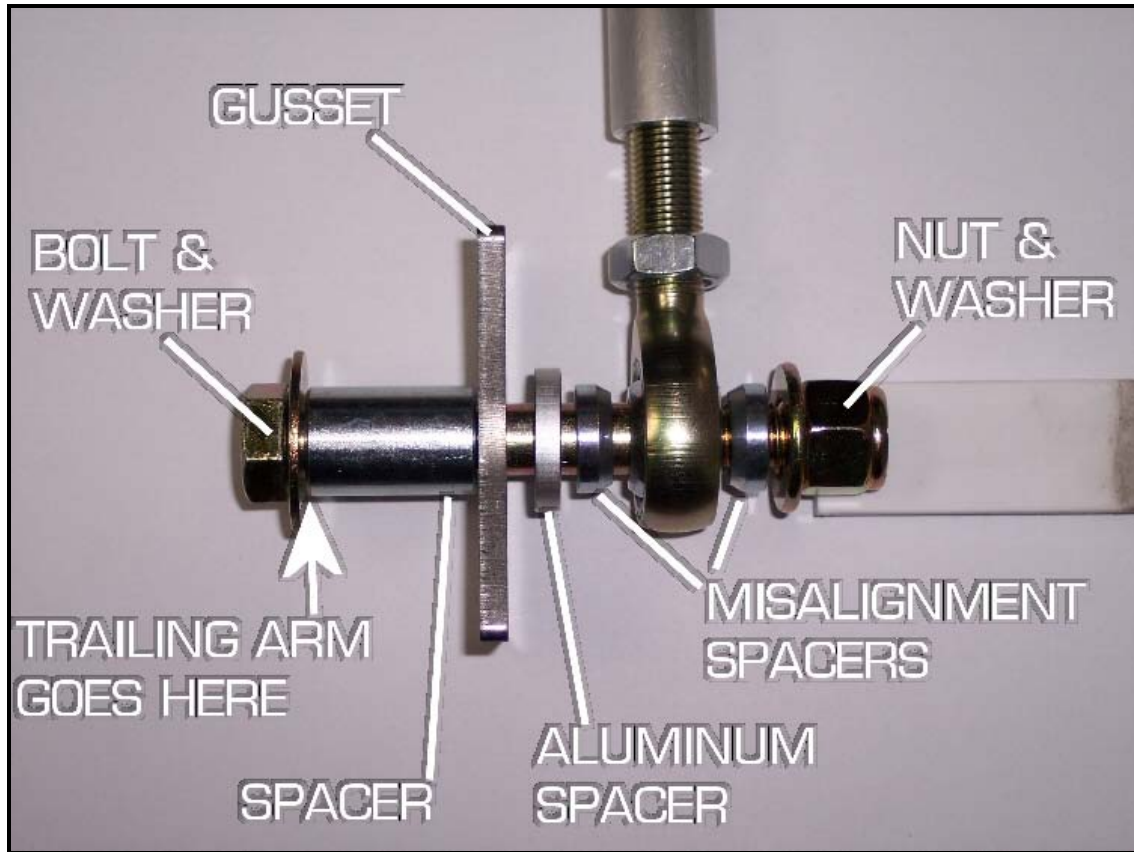

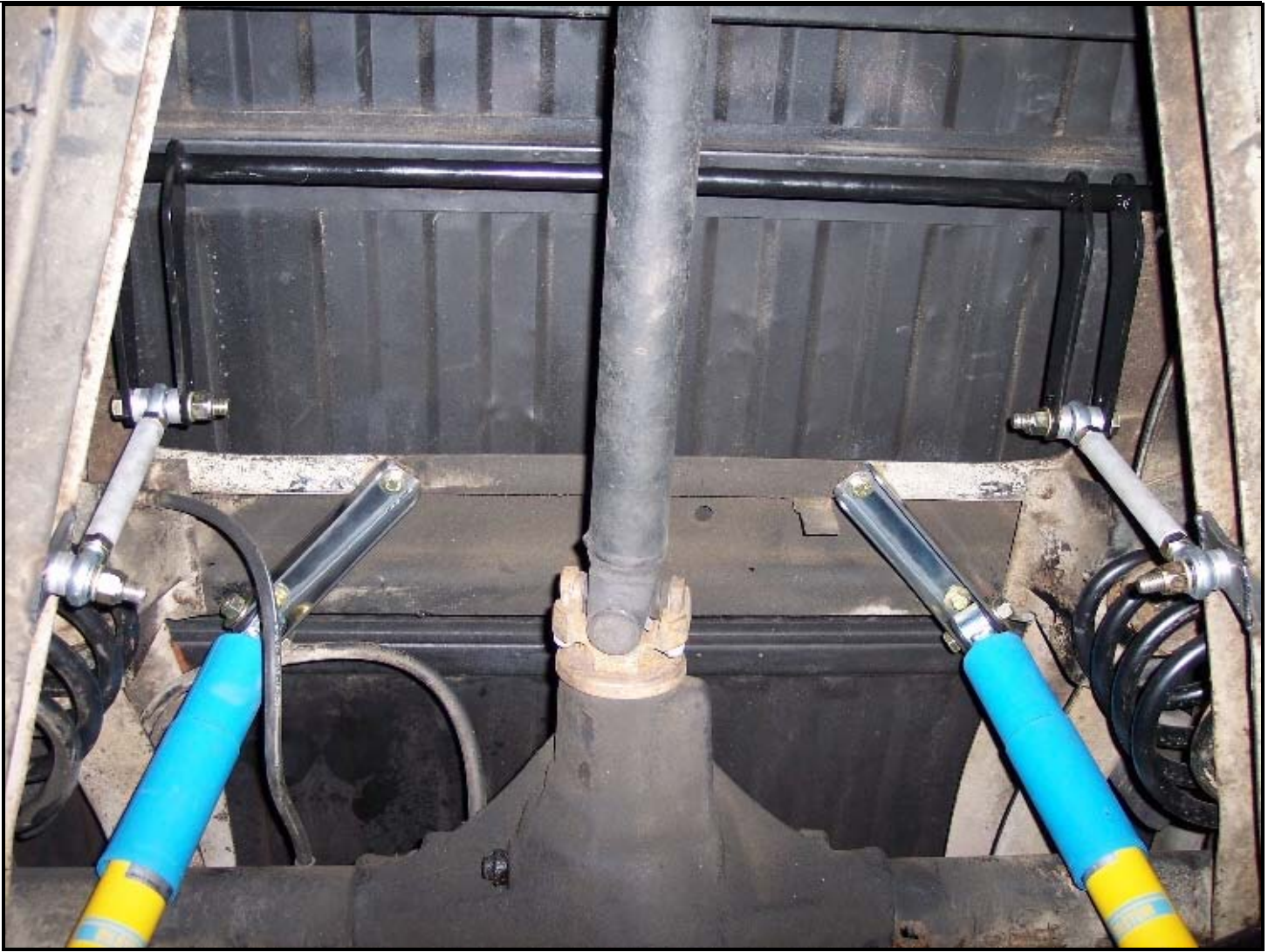

Check out our other great products for your C10 Pickup at Hotchkis.net
- 19390 Sport Coil Springs (4/6 Drop)

- 11390U Tubular Upper A-Arms (Better Camber Curve)
- 11390L Tubular Lower A-Arms (Increased Caster for Stability and Cornering Grip)
- 30390 Anti-Squat Kit (Increased anti-squat for better launches)
- 18390 Rear Suspension Package (Quality rear shocks and longer/lower track bar for improved rear grip)
- 70390 Front Shock Kit (Re-positions front Bilstein shocks for more travel for lower trucks)



Hotchkis Performance LLC
Return Policy & Limited Warranty



Effective December 1, 2010 all Hotchkis products must be registered to qualify for warranty at www.hotchkis.net or via the mail-in warranty card, included with the product, within 30 days of the original purchase date.

IMPORTANT: This warranty supersedes all other warranties included with this product.

Return Policy

We want you to be completely satisfied with your Hotchkis Performance product. For products, presenting signs of shipping damage please contact the freight carrier immediately. All our products are guaranteed to be free from manufacturer's defects. If your order arrives with a manufacture defect, please contact our Customer Service Department at (562) 907-7757. You will be assigned a Returned Goods Authorization Number (RGA). The package you return must show the RGA on the outside of the package, include the original invoice and be shipped prepaid to our facility. The product has to be unused and in its original packaging materials. Exchanges or refunds made after 30 days will be subject to a 20% restocking charge. **If you purchased your Hotchkis Performance product from an authorized dealer, you are still covered by this return policy. All returns however, should be made to your dealer, not to Hotchkis Performance directly.**

Limited Warranty

Hotchkis Performance offers a Limited Warranty against defects in materials and workmanship for the term of 36 months (3 years) from the date of purchase of this product. This Warranty only applies to the original retail purchaser who retains ownership of the vehicle on which the product was originally installed. If the product is determined to be defective, Hotchkis Performance will repair, replace or refund the purchase price of the defective product at Hotchkis Performance's sole discretion, which shall fully satisfy and discharge any and all warranty claims. Any repaired or replaced product will be returned to the sender excluding the cost of freight. **Products must be registered to qualify for warranty at www.hotchkis.net or via the mail-in warranty card, included with the product, within 30 days of the original purchase date.**

Exclusions from Warranty

Items offered but not manufactured by Hotchkis Performance are warranted according to the manufacturer's terms and are not covered by this limited warranty. Hotchkis Performance shall not be responsible for any labor, removal, installation, re-installation or maintenance costs. This warranty does not cover the cosmetic finish or plating of any product or any normal wear and tear to any product including, but not limited to bushings, brackets, end-links, hardware, steering components, shocks or springs. In addition, this warranty does not apply to any products that have been:

- Improperly installed or installed by someone other than a qualified, licensed auto mechanic experienced in the installation and removal of suspension products;
- Improperly serviced, misused, or modified, altered or subjected to abuse, negligence, accident or collision;
- Installed in any vehicle that has been modified;
- Installed on any vehicle that has carried loads in excess of automobile manufacturer suggested weight limits; or
- Installed on any vehicle that has been subject to abnormal or excessive use, including rallying, racing, or racing-type activities or off-road use.

Limitation of Warranty

This limited warranty is the entire and only warranty for the products and may not be modified or supplemented by any other person or company in any form. Any description of the products, by anyone, is for the sole purpose of identifying them and is not part of the basis of the bargain, and does not constitute a warranty that the products will conform to that description. The statements of any salesperson do not constitute part of this limited warranty and cannot be relied upon as a warranty.

THERE ARE NO WARRANTIES, EXPRESSED OR IMPLIED, INCLUDING ANY IMPLIED WARRANTIES OF MERCHANTABILITY OR FITNESS FOR A PARTICULAR PURPOSE, WHICH EXTEND BEYOND THE DESCRIPTION ON THE FACE HEREOF. ANY IMPLIED WARRANTIES ARE DISCLAIMED TO THE FULLEST EXTENT PERMITTED BY LAW. THIS WARRANTY DOES NOT COVER CONSEQUENTIAL DAMAGES, LOSS OF TIME OR REVENUES, INCONVENIENCE, LOSS OF USE OF THE VEHICLE, DAMAGE TO THE VEHICLE OR COMPONENTS OF THE VEHICLE, ANY OTHER TYPE OF CONSEQUENTIAL DAMAGES, OR OTHER INCIDENTAL OR INDIRECT DAMAGES. HOTCHKIS' MAXIMUM LIABILITY UNDER THIS WARRANTY SHALL IN NO EVENT EXCEED THE PURCHASE PRICE OF THE PRODUCT. Some states do not allow limitations on how long an implied warranty lasts or the exclusion or



limitation of incidental or consequential damages and in such states the above limitations or exclusions may not apply. This limited warranty gives the purchaser specific legal rights and the purchaser may have other rights that may vary from state to state.

Technical Information

Hotchkis Performance makes every effort to ensure that you are provided with the most accurate and up-to-date technical information. However, all technical information is approximate and may vary upon application. Additional suspension components may be needed in some applications, depending upon the make, model, engine and chassis of the vehicle. Hotchkis Performance is not responsible for any consequences resulting from manufacturer's technical mid-year changes. Hotchkis Performance products should only be installed by a qualified, licensed auto mechanic experienced in the installation of such products.

Warranty Claim Procedure:

The answer to ALL the following questions should be YES before making a warranty claim:

- Did you register the product at www.hotchkis.net or via the mail-in warranty card within 30 days of purchase?
- Is the product appropriate to your application?
- Did you carefully and thoroughly read the instructions provided along with the product?
- Do you have the original invoice or sales receipt?
- Is the return date within 36 months from the purchase date?
- Are you the original purchaser?
- Was the product properly installed by a qualified, licensed auto mechanic?
- Has the product been installed on the original vehicle on which it was installed at all times?
- Is the product unmodified and clean?
- Is the reason for return a legitimate product defect?

If the answer to all these questions is YES, please contact our Customer Service Department at (562) 907-7757. You will be given a Returned Goods Authorization Number (RGA) valid for 60 days. You will also be asked to ship the product prepaid to our facility. All shipments MUST be (i) prepaid, (ii) include the original invoice or sales receipt, (iii) show the RGA on the outside of the package and (iv) include your name, address, make and model of the vehicle, and a brief description of the claimed defect, including the circumstances under which the defect occurred. If the warranty claim is deemed valid then Hotchkis will estimate shipping costs to return the repaired or replacement part and contact you for payment. Hotchkis's Limited warranty requires that any repaired or replaced product will be returned to the sender excluding the cost of freight. Warranty related inquiries should be sent to the following address:

**HOTCHKIS PERFORMANCE, LLC
C/O CUSTOMER SERVICE
8633 Sorensen Avenue
SANTA FE SPRINGS, CA 90670**

Hotchkis Performance will not accept product returns without the RGA number, receipt and the information described above. C.O.D. or collect shipments will be refused. Once the returns are received at Hotchkis Performance, we will evaluate the products, verify the sales receipt, and investigate the warranty claim. Any repaired or replaced product will be returned to the sender.

Effective December 1, 2010. This return policy and limited warranty supersedes all previous policy and warranty statements. Policies and warranties are subject to change without notice. Hotchkis Performance is not responsible for printing errors.

Anti-Squat Kit 30390 *67-72 C-10 Truck*

*Thank you for your purchase from our new line of Chevy parts.
Please call us at 877 - 4NO - ROLL if you have any questions
regarding the service or installation of your Hotchkis Performance products.*

**IMPORTANT: PLEASE READ THE ENTIRE INSTRUCTION MANUAL BEFORE
STARTING THIS INSTALLATION.**



Installation of Anti-Squat Kit

1 ***Raising Car***

Raise rear of the vehicle by using a 4 post lift. Securely block the front wheels of the vehicle. Do not remove the rear wheels during installation.



2 ***Support the Rear Section***

Once the truck is on a 4-post lift, jack up the rear section of the truck. Support the truck at the frame rails and not at the axle. Raise the rear until most of the load is off the rear wheels. The wheels should still be touching the lift surface.

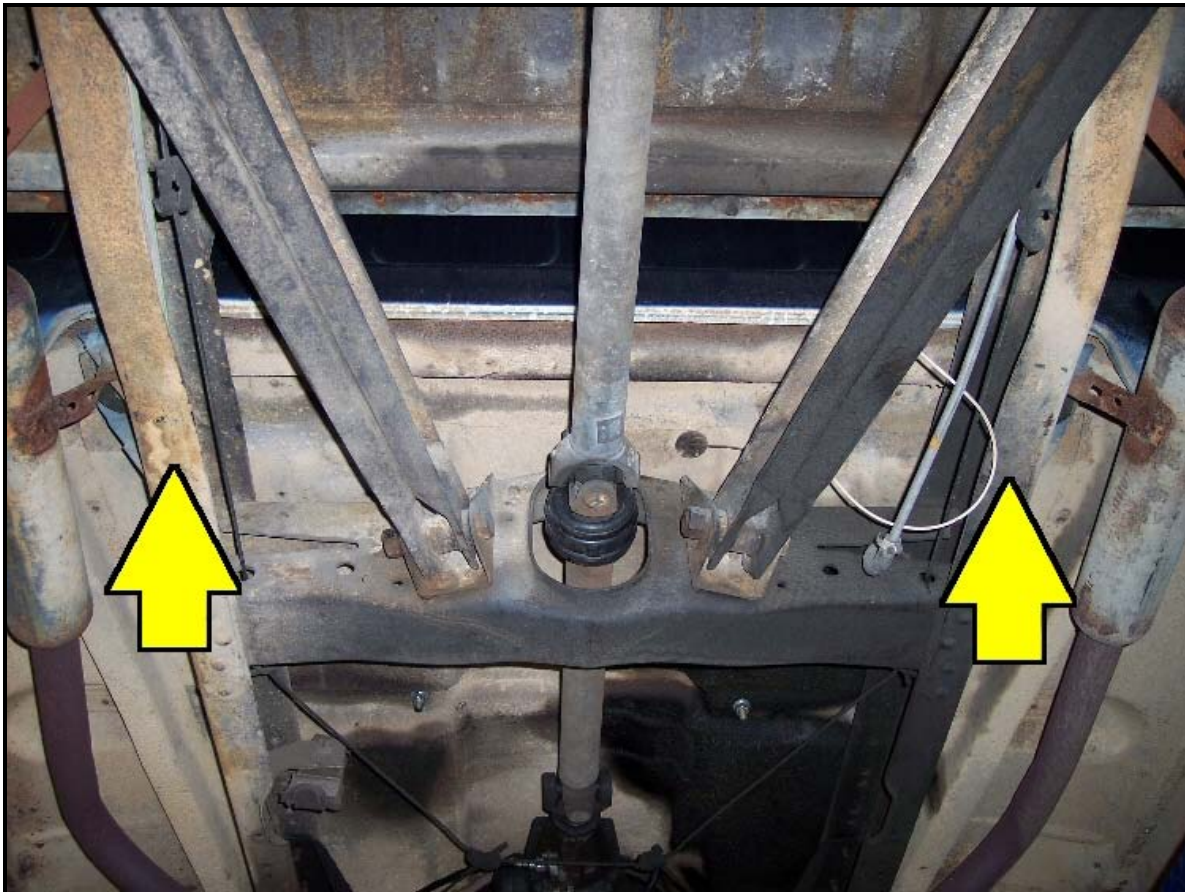

Use another jack to support the front ends of the trailing arms.



3 ***Remove Original Front Trailing Arm Mounts***

Unfasten the large $\frac{3}{4}$ " bolts holding the front ends of the trailing arms. Lower the jack supporting the trailing arms and they should slide down from the bracket mounts.

Each mount is secured with 6 factory rivets. Use an air chisel to remove the rivet heads. Once the heads are removed, you can punch the rest of the rivet out and remove the original bracket from the truck.

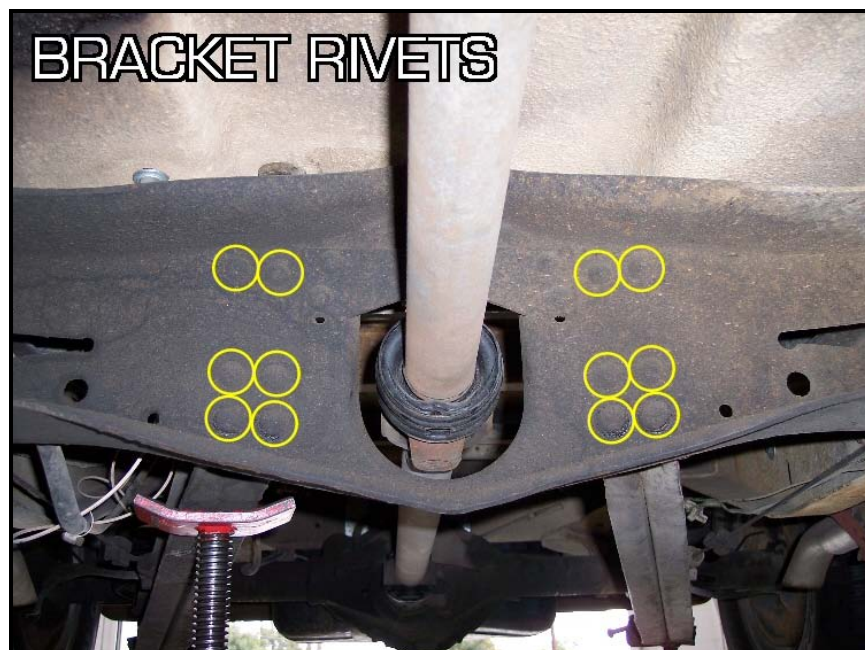

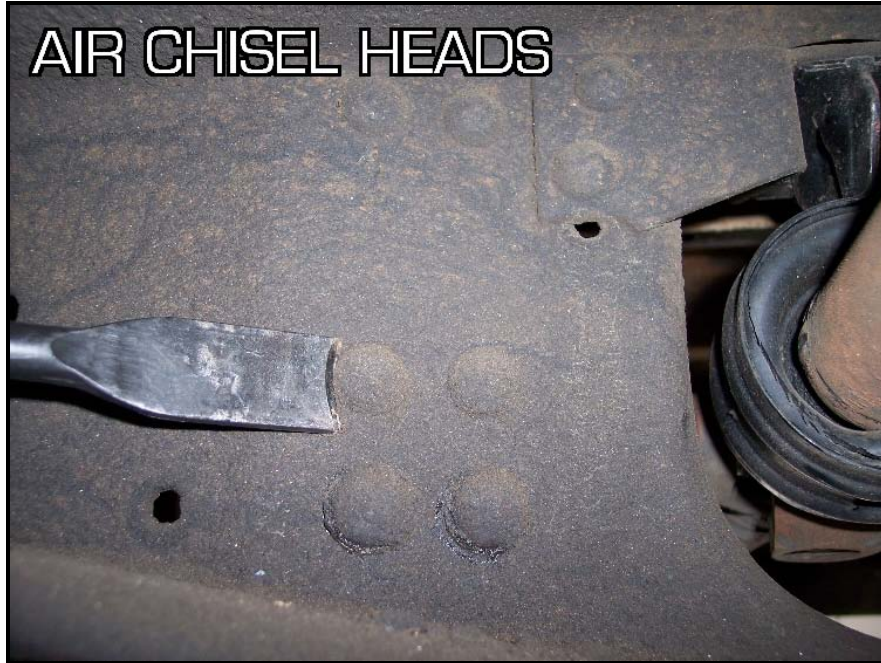

- 4 ***Install Hotchkis Trailing Arm Mounts***
Replace the original mounts with the Hotchkis Mounts. Mounting hardware is provided to replace the rivets that were removed. Install the bracket as shown in the diagram.

FRONT

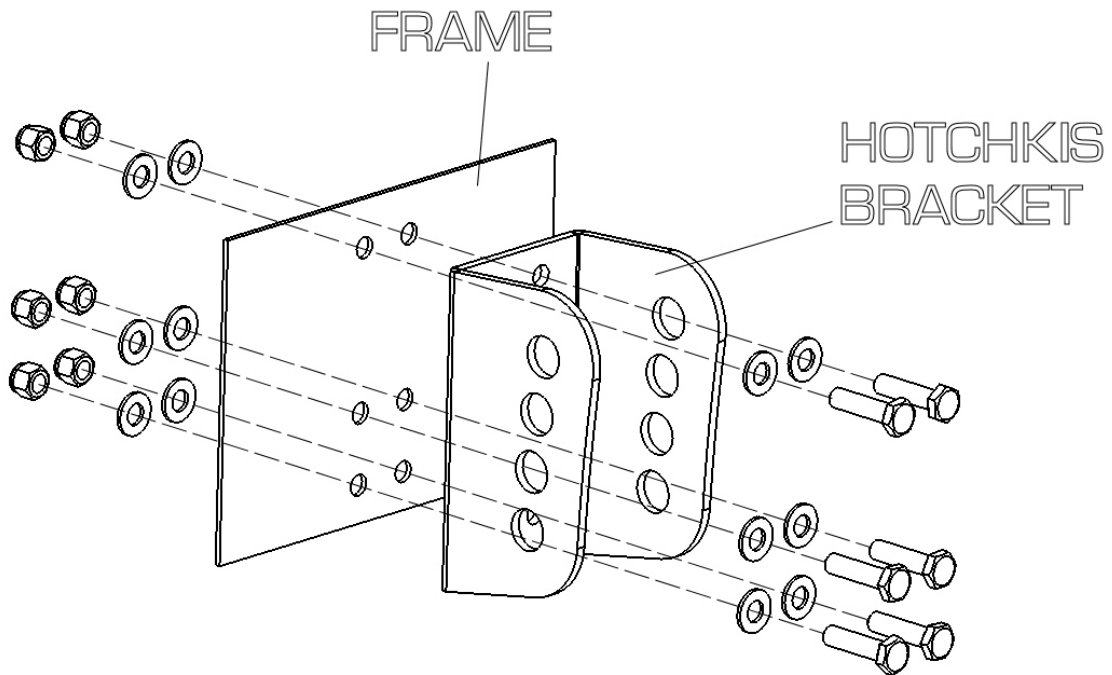

5 **Reinstall the Trailing Arms**

The Hotchkis trailing arm brackets have 4 holes to choose from. The lowest hole is the same as the original. As you move up in holes, the angle of the trailing arm increases by 1°. The higher the hole used, the more anti-squat you will get. You may want to experiment with different holes to determine the best setup for your truck. As a default you can install the trailing arm in the lowest hole.

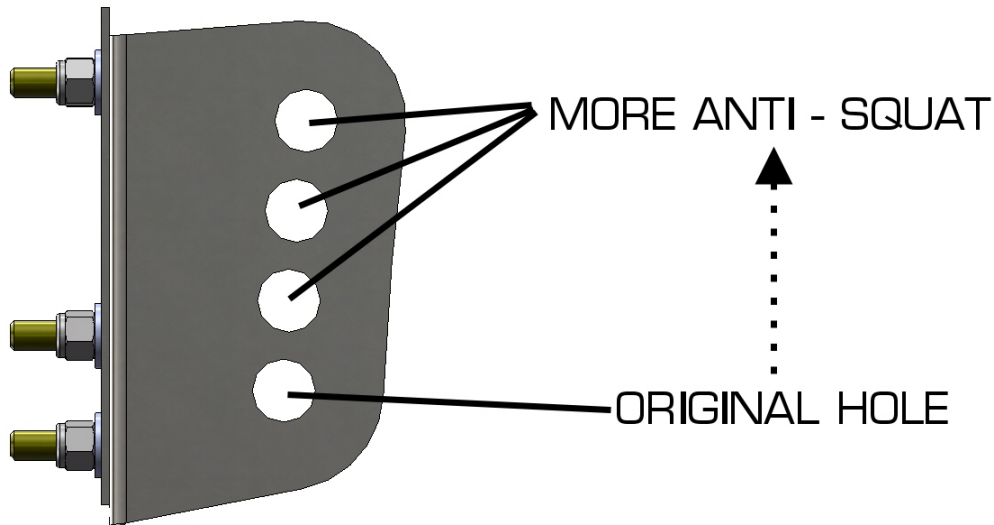

You Hotchkis kit utilize spacer washers to give the trailing arm some room to articulate. Install 1 spacer on each side of the trailing arm. So each arm will have 2 spacers used total. Install the new hardware. Fasten the large bolts, but do not fully tighten at this time. You do not want to preload the bushings!

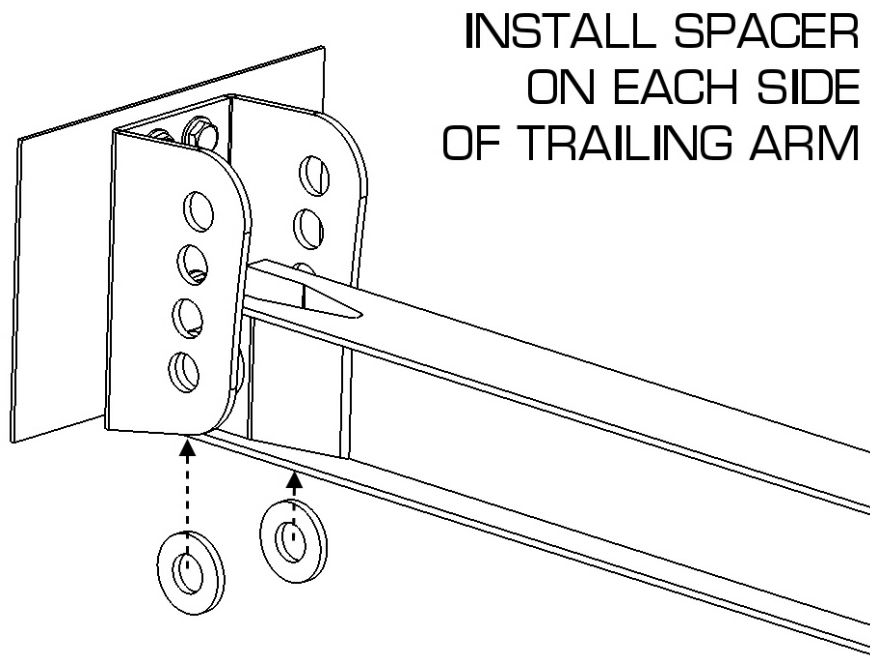

5 ***Optional Pinion Shim***

We also include an optional shim in case you would like to change your pinion angle. The shim will change your pinion angle by 5°. Depending on the ride height of your truck and driveline angle, this shim may or may not be needed. The shim goes between the rear end mount and the trailing arms. Use the included longer u-bolts when using the shim and/or with our #18390 Rear Suspension Package.

6 ***Tighten Hardware***

Lower all jacks and let the load rest on the wheels. Fully tighten the ¾" bolts at the front of the trailing arms.

Check out our other great products for your C10 Pickup at Hotchkis.net

- 19390 Sport Coil Springs (4/6 Drop)
- 11390U Tubular Upper A-Arms (Better Camber Curve)
- 11390L Tubular Lower A-Arms (Increased Caster for Stability and Cornering Grip)
- 22390 Sway Bar Kit (Reduce Body Roll and Enhance Vehicle Response)
- 18390 Rear Suspension Package (Quality rear shocks and longer/lower track bar for improved rear grip)
- 70390 Front Shock Kit (Re-positions front Bilstein shocks for more travel for lower trucks)

Return Policy & Limited Warranty

Effective December 1, 2010 all Hotchkis products must be registered to qualify for warranty at www.hotchkis.net or via the mail-in warranty card, included with the product, within 30 days of the original purchase date.

IMPORTANT: This warranty supersedes all other warranties included with this product.

Return Policy

We want you to be completely satisfied with your Hotchkis Performance product. For products, presenting signs of shipping damage please contact the freight carrier immediately. All our products are guaranteed to be free from manufacturer's defects. If your order arrives with a manufacture defect, please contact our Customer Service Department at (562) 907-7757. You will be assigned a Returned Goods Authorization Number (RGA). The package you return must show the RGA on the outside of the package, include the original invoice and be shipped prepaid to our facility. The product has to be unused and in its original packaging materials. Exchanges or refunds made after 30 days will be subject to a 20% restocking charge. **If you purchased your Hotchkis Performance product from an authorized dealer, you are still covered by this return policy. All returns however, should be made to your dealer, not to Hotchkis Performance directly.**

Limited Warranty

Hotchkis Performance offers a Limited Warranty against defects in materials and workmanship for the term of 36 months (3 years) from the date of purchase of this product. This Warranty only applies to the original retail purchaser who retains ownership of the vehicle on which the product was originally installed. If the product is determined to be defective, Hotchkis Performance will repair, replace or refund the purchase price of the defective product at Hotchkis Performance's sole discretion, which shall fully satisfy and discharge any and all warranty claims. Any repaired or replaced product will be returned to the sender excluding the cost of freight. **Products must be registered to qualify for warranty at www.hotchkis.net or via the mail-in warranty card, included with the product, within 30 days of the original purchase date.**

Exclusions from Warranty

Items offered but not manufactured by Hotchkis Performance are warranted according to the manufacturer's terms and are not covered by this limited warranty. Hotchkis Performance shall not be responsible for any labor, removal, installation, re-installation or maintenance costs. This warranty does not cover the cosmetic finish or plating of any product or any normal wear and tear to any product including, but not limited to bushings, brackets, end-links, hardware, steering components, shocks or springs. In addition, this warranty does not apply to any products that have been:

- Improperly installed or installed by someone other than a qualified, licensed auto mechanic experienced in the installation and removal of suspension products;
- Improperly serviced, misused, or modified, altered or subjected to abuse, negligence, accident or collision;
- Installed in any vehicle that has been modified;
- Installed on any vehicle that has carried loads in excess of automobile manufacturer suggested weight limits; or
- Installed on any vehicle that has been subject to abnormal or excessive use, including rallying, racing, or racing-type activities or off-road use.

Limitation of Warranty

This limited warranty is the entire and only warranty for the products and may not be modified or supplemented by any other person or company in any form. Any description of the products, by anyone, is for the sole purpose of identifying them and is not part of the basis of the bargain, and does not constitute a warranty that the products will conform to that description. The statements of any salesperson do not constitute part of this limited warranty and cannot be relied upon as a warranty.

THERE ARE NO WARRANTIES, EXPRESSED OR IMPLIED, INCLUDING ANY IMPLIED WARRANTIES OF MERCHANTABILITY OR FITNESS FOR A PARTICULAR PURPOSE, WHICH EXTEND BEYOND THE DESCRIPTION ON THE FACE HEREOF. ANY IMPLIED WARRANTIES ARE DISCLAIMED TO THE FULLEST EXTENT PERMITTED BY LAW. THIS WARRANTY DOES NOT COVER CONSEQUENTIAL DAMAGES, LOSS OF TIME OR REVENUES, INCONVENIENCE, LOSS OF USE OF THE VEHICLE, DAMAGE TO THE VEHICLE OR COMPONENTS OF THE VEHICLE, ANY OTHER TYPE OF CONSEQUENTIAL DAMAGES, OR OTHER INCIDENTAL OR INDIRECT DAMAGES. HOTCHKIS'



MAXIMUM LIABILITY UNDER THIS WARRANTY SHALL IN NO EVENT EXCEED THE PURCHASE PRICE OF THE PRODUCT. Some states do not allow limitations on how long an implied warranty lasts or the exclusion or limitation of incidental or consequential damages and in such states the above limitations or exclusions may not apply. This limited warranty gives the purchaser specific legal rights and the purchaser may have other rights that may vary from state to state.

Technical Information

Hotchkis Performance makes every effort to ensure that you are provided with the most accurate and up-to-date technical information. However, all technical information is approximate and may vary upon application. Additional suspension components may be needed in some applications, depending upon the make, model, engine and chassis of the vehicle. Hotchkis Performance is not responsible for any consequences resulting from manufacturer's technical mid-year changes. Hotchkis Performance products should only be installed by a qualified, licensed auto mechanic experienced in the installation of such products.

Warranty Claim Procedure:

The answer to ALL the following questions should be YES before making a warranty claim:

- Did you register the product at www.hotchkis.net or via the mail-in warranty card within 30 days of purchase?
- Is the product appropriate to your application?
- Did you carefully and thoroughly read the instructions provided along with the product?
- Do you have the original invoice or sales receipt?
- Is the return date within 36 months from the purchase date?
- Are you the original purchaser?
- Was the product properly installed by a qualified, licensed auto mechanic?
- Has the product been installed on the original vehicle on which it was installed at all times?
- Is the product unmodified and clean?
- Is the reason for return a legitimate product defect?

If the answer to all these questions is YES, please contact our Customer Service Department at (562) 907-7757. You will be given a Returned Goods Authorization Number (RGA) valid for 60 days. You will also be asked to ship the product prepaid to our facility. All shipments MUST be (i) prepaid, (ii) include the original invoice or sales receipt, (iii) show the RGA on the outside of the package and (iv) include your name, address, make and model of the vehicle, and a brief description of the claimed defect, including the circumstances under which the defect occurred. If the warranty claim is deemed valid then Hotchkis will estimate shipping costs to return the repaired or replacement part and contact you for payment. Hotchkis's Limited warranty requires that any repaired or replaced product will be returned to the sender excluding the cost of freight. Warranty related inquiries should be sent to the following address:

**HOTCHKIS PERFORMANCE, LLC
C/O CUSTOMER SERVICE
8633 Sorensen Avenue
SANTA FE SPRINGS, CA 90670**

Hotchkis Performance will not accept product returns without the RGA number, receipt and the information described above. C.O.D. or collect shipments will be refused. Once the returns are received at Hotchkis Performance, we will evaluate the products, verify the sales receipt, and investigate the warranty claim. Any repaired or replaced product will be returned to the sender.

Effective December 1, 2010. This return policy and limited warranty supersedes all previous policy and warranty statements. Policies and warranties are subject to change without notice. Hotchkis Performance is not responsible for printing errors.

67-72 GM C-10 TRUCK
70390
FRONT SHOCKS W/ RELOCATORS

*Thank you for your purchase.
Please call us at 877 - 4NO - ROLL if you have any questions
regarding the service or installation of your Hotchkis Performance products.
Please read the entire Instruction Manual before starting the installation.*

- 1) Remove the front shocks that are currently on the vehicle.



2) Remove the upper shock stud chassis mount on the frame.

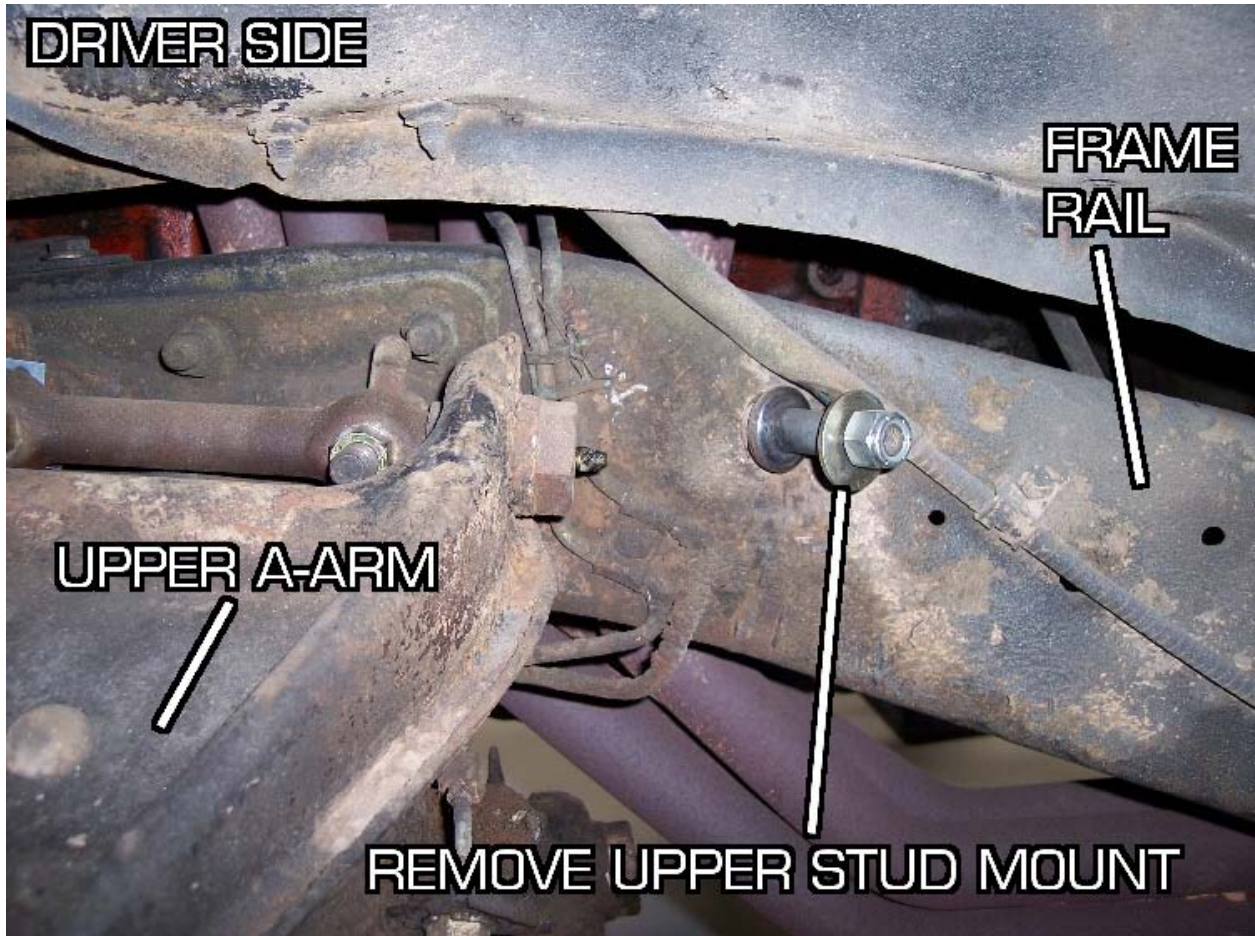

3) On the driver side just to the right of the old stud mount, there is a small frame hole you will use for reference. (see picture) If you follow a straight line up and over to the top of the frame rail, you will find another hole. This will be the location of the top hole for the Hotchkis Bracket. Drill out this top hole with a 1/2" drill bit. (Tip: Accessing this may be easier from the engine bay)

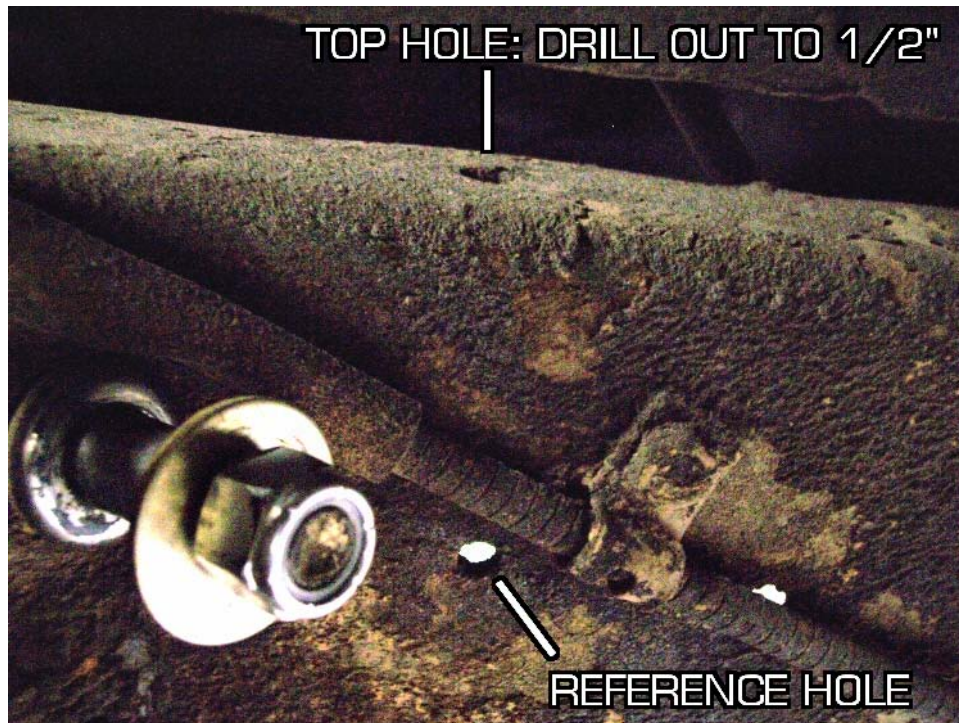
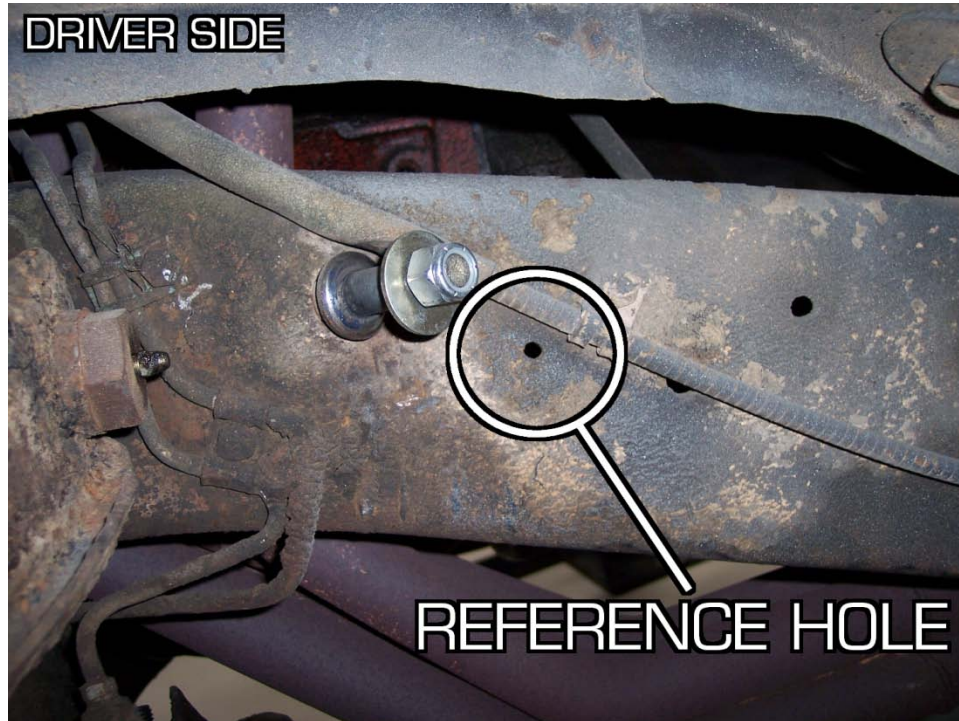

Some later trucks (71-72) may not have the reference hole shown on the previous pictures. If so, you may use the larger hole shown below as reference. The centerline of the Hotchkis bracket holes are 2.25" forward of the large reference hole.

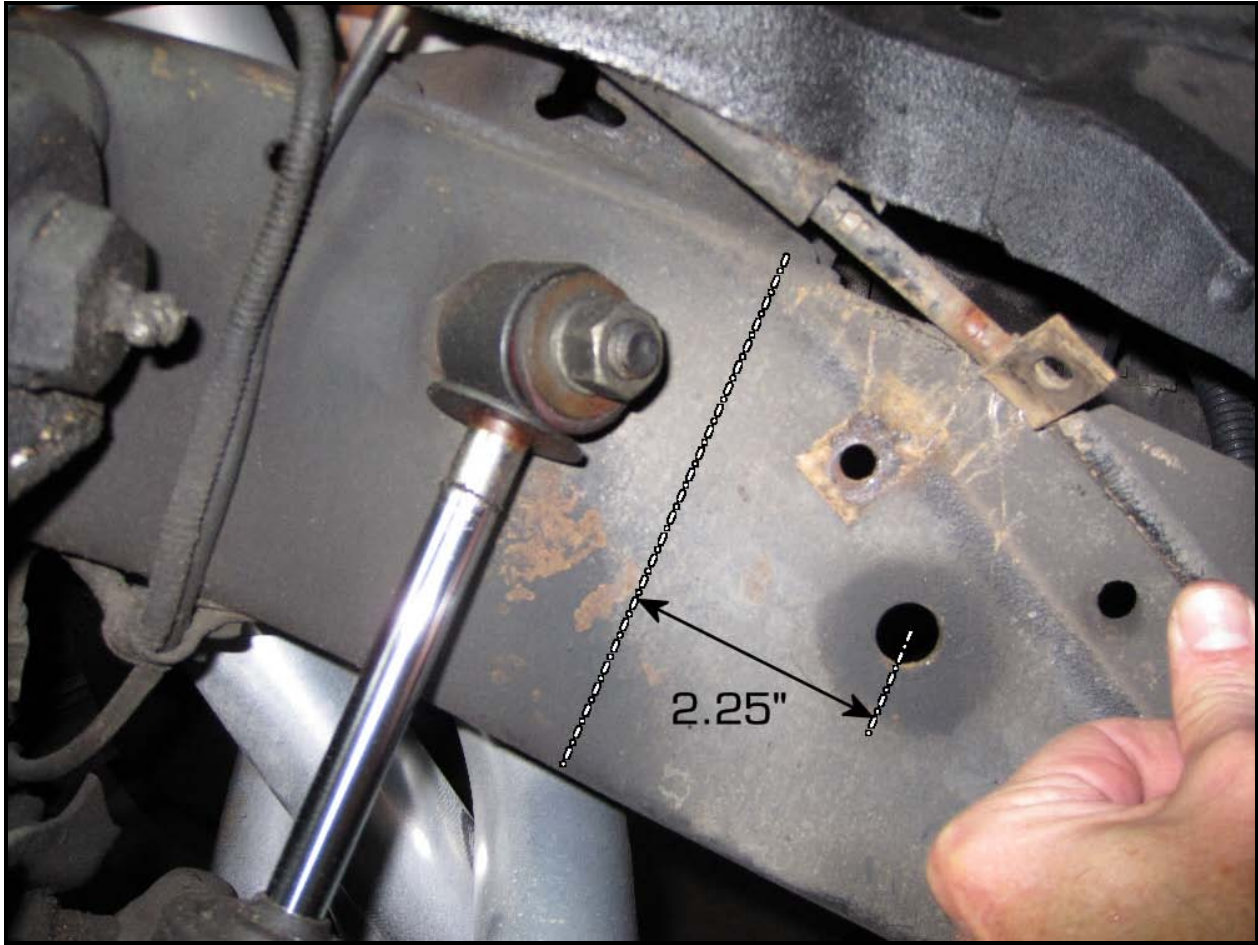

4) Position the driver side Hotchkis bracket in place with the supplied ½" bolt passing through the top hole to position it properly. Once in place, mark the frame rail for the lower hole. Drill this out using the ½" drill as well. With both top and bottom holes drilled. Install the included ½" hardware to mount the bracket. Make sure to use the supplied washers for the bolt head and the nylock nut. Fully tighten.

DRIVER SIDE

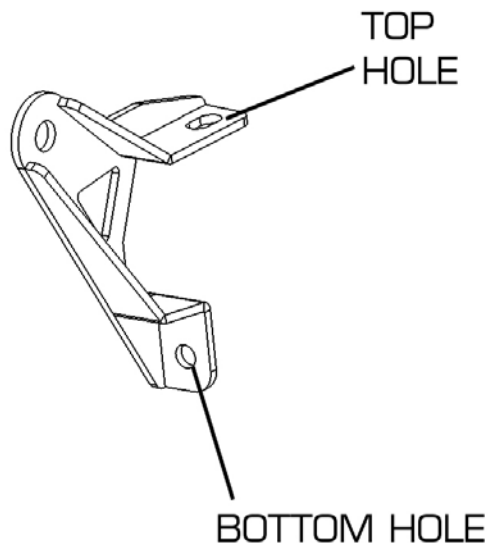

5) Repeat this process on the passenger side. The pass. side does not have an existing top hole to use as a guide, but you can still use the small hole facing you as a reference point. Use the bracket as a guide to mark your two holes and drill. Bolt together in the same manner as the driver side.

6) Install your Hotchkis tuned Bilstein shocks in the same manner as removal. Only this time the upper mount attaches to the Hotchkis bracket. The bushing stud on the top end of the shock should point toward the rear of the car.



***Check out our other great products for your C10 Pickup at
Hotchkis.net***

- 19390 Sport Coil Springs (4/6 Drop)
- 11390U Tubular Upper A-Arms (Improved Camber Curve)
- 11390L Tubular Lower A-Arms (Increased Caster for Stability and Cornering Grip)
- 18390 Rear Suspension Package (Quality rear shocks and longer/lower track bar for improved rear grip)
- 22390 Sway Bar Kit (Reduce Body Roll and Enhance Vehicle Response)
- 30390 Anti-Squat Kit (Increased anti-squat for better launches)
- 70390 Front Shock Kit (Re-positions front Bilstein shocks for more travel for lowered trucks)



Hotchkis Performance LLC

Return Policy & Limited Warranty

Effective December 1, 2010 all Hotchkis products must be registered to qualify for warranty at www.hotchkis.net or via the mail-in warranty card, included with the product, within 30 days of the original purchase date.

IMPORTANT: This warranty supersedes all other warranties included with this product.

Return Policy

We want you to be completely satisfied with your Hotchkis Performance product. For products, presenting signs of shipping damage please contact the freight carrier immediately. All our products are guaranteed to be free from manufacturer's defects. If your order arrives with a manufacture defect, please contact our Customer Service Department at (562) 907-7757. You will be assigned a Returned Goods Authorization Number (RGA). The package you return must show the RGA on the outside of the package, include the original invoice and be shipped prepaid to our facility. The product has to be unused and in its original packaging materials. Exchanges or refunds made after 30 days will be subject to a 20% restocking charge. **If you purchased your Hotchkis Performance product from an authorized dealer, you are still covered by this return policy. All returns however, should be made to your dealer, not to Hotchkis Performance directly.**

Limited Warranty

Hotchkis Performance offers a Limited Warranty against defects in materials and workmanship for the term of 36 months (3 years) from the date of purchase of this product. This Warranty only applies to the original retail purchaser who retains ownership of the vehicle on which the product was originally installed. If the product is determined to be defective, Hotchkis Performance will repair, replace or refund the purchase price of the defective product at Hotchkis Performance's sole discretion, which shall fully satisfy and discharge any and all warranty claims. Any repaired or replaced product will be returned to the sender excluding the cost of freight. **Products must be registered to qualify for warranty at www.hotchkis.net or via the mail-in warranty card, included with the product, within 30 days of the original purchase date.**

Exclusions from Warranty

Items offered but not manufactured by Hotchkis Performance are warranted according to the manufacturer's terms and are not covered by this limited warranty. Hotchkis Performance shall not be responsible for any labor, removal, installation, re-installation or maintenance costs. This warranty does not cover the cosmetic finish or plating of any product or any normal wear and tear to any product including, but not limited to bushings, brackets, end-links, hardware, steering components, shocks or springs. In addition, this warranty does not apply to any products that have been:

- Improperly installed or installed by someone other than a qualified, licensed auto mechanic experienced in the installation and removal of suspension products;
- Improperly serviced, misused, or modified, altered or subjected to abuse, negligence, accident or collision;
- Installed in any vehicle that has been modified;
- Installed on any vehicle that has carried loads in excess of automobile manufacturer suggested weight limits; or
- Installed on any vehicle that has been subject to abnormal or excessive use, including rallying, racing, or racing-type activities or off-road use.

Limitation of Warranty

This limited warranty is the entire and only warranty for the products and may not be modified or supplemented by any other person or company in any form. Any description of the products, by anyone, is for the sole purpose of identifying them and is not part of the basis of the bargain, and does not

constitute a warranty that the products will conform to that description. The statements of any salesperson do not constitute part of this limited warranty and cannot be relied upon as a warranty.

THERE ARE NO WARRANTIES, EXPRESSED OR IMPLIED, INCLUDING ANY IMPLIED WARRANTIES OF MERCHANTABILITY OR FITNESS FOR A PARTICULAR PURPOSE, WHICH EXTEND BEYOND THE DESCRIPTION ON THE FACE HEREOF. ANY IMPLIED WARRANTIES ARE DISCLAIMED TO THE FULLEST EXTENT PERMITTED BY LAW. THIS WARRANTY DOES NOT COVER CONSEQUENTIAL DAMAGES, LOSS OF TIME OR REVENUES, INCONVENIENCE, LOSS OF USE OF THE VEHICLE, DAMAGE TO THE VEHICLE OR COMPONENTS OF THE VEHICLE, ANY OTHER TYPE OF CONSEQUENTIAL DAMAGES, OR OTHER INCIDENTAL OR INDIRECT DAMAGES. HOTCHKIS' MAXIMUM LIABILITY UNDER THIS WARRANTY SHALL IN NO EVENT EXCEED THE PURCHASE PRICE OF THE PRODUCT. Some states do not allow limitations on how long an implied warranty lasts or the exclusion or limitation of incidental or consequential damages and in such states the above limitations or exclusions may not apply. This limited warranty gives the purchaser specific legal rights and the purchaser may have other rights that may vary from state to state.

Technical Information

Hotchkis Performance makes every effort to ensure that you are provided with the most accurate and up-to-date technical information. However, all technical information is approximate and may vary upon application. Additional suspension components may be needed in some applications, depending upon the make, model, engine and chassis of the vehicle. Hotchkis Performance is not responsible for any consequences resulting from manufacturer's technical mid-year changes. Hotchkis Performance products should only be installed by a qualified, licensed auto mechanic experienced in the installation of such products.

Warranty Claim Procedure:

The answer to ALL the following questions should be YES before making a warranty claim:

- Did you register the product at www.hotchkis.net or via the mail-in warranty card within 30 days of purchase?
- Is the product appropriate to your application?
- Did you carefully and thoroughly read the instructions provided along with the product?
- Do you have the original invoice or sales receipt?
- Is the return date within 36 months from the purchase date?
- Are you the original purchaser?
- Was the product properly installed by a qualified, licensed auto mechanic?
- Has the product been installed on the original vehicle on which it was installed at all times?
- Is the product unmodified and clean?
- Is the reason for return a legitimate product defect?

If the answer to all these questions is YES, please contact our Customer Service Department at (562) 907-7757. You will be given a Returned Goods Authorization Number (RGA) valid for 60 days. You will also be asked to ship the product prepaid to our facility. All shipments MUST be (i) prepaid, (ii) include the original invoice or sales receipt, (iii) show the RGA on the outside of the package and (iv) include your name, address, make and model of the vehicle, and a brief description of the claimed defect, including the circumstances under which the defect occurred. If the warranty claim is deemed valid then Hotchkis will estimate shipping costs to return the repaired or replacement part and contact you for payment. Hotchkis's Limited warranty requires that any repaired or replaced product will be returned to the sender excluding the cost of freight. Warranty related inquiries should be sent to the following address:

HOTCHKIS PERFORMANCE, LLC
C/O CUSTOMER SERVICE
8633 Sorensen Avenue

SANTA FE SPRINGS, CA 90670

Hotchkis Performance will not accept product returns without the RGA number, receipt and the information described above. C.O.D. or collect shipments will be refused. Once the returns are received at Hotchkis Performance, we will evaluate the products, verify the sales receipt, and investigate the warranty claim. Any repaired or replaced product will be returned to the sender.

Effective December 1, 2010. This return policy and limited warranty supersedes all previous policy and warranty statements. Policies and warranties are subject to change without notice. Hotchkis Performance is not responsible for printing errors.