



## INSTALLATION INSTRUCTIONS

1075 North Ave. Sanger, CA 93657-3539 local: 559-875-0222 fax: 559-876-2259 toll free: 800-445-3767

### 5555 REAR ANTI-SWAY BAR 2004 DODGE RAM REAR ANTI-SWAY BAR

**Congratulations! You were selective enough to choose a BELLTECH PRODUCT. We have spent many hours developing our line of products so that you will receive maximum performance with minimum difficulty during installation.**

- Note: Confirm that all of the hardware listed in the parts list is in the kit. **Do not** begin installation if any part is missing. Read the instructions thoroughly before beginning this installation.
- Warning:** **DO NOT** work under a vehicle supported by only a jack. Place support stands securely under the vehicle in the manufacturer's specified locations unless otherwise instructed.
- Warning:** **DO NOT** drive vehicle until all work has been completed and checked. Torque all hardware to values specified.
- Reminder: Proper use of safety equipment and eye/face/hand protection is absolutely necessary when using these tools to perform procedures!
- Note: It is very helpful to have an assistant available during installation.

#### RECOMMENDED TOOLS:

- Properly rated floor jack, support stands, and wheel chocks
- Combination wrench: 9/16"
- Torque wrench: 0-75 lb ft. range
- Ratcheting socket wrench and sockets: 10mm, 9/16"
- Safety Glasses

#### KIT INSTALLATION

1. Open the hardware kit and remove all of the contents. Refer to the part list (Page 3) to verify that all parts are present.
2. Park the vehicle on a smooth, level concrete or seasoned asphalt surface and activate the parking brake. Block the FRONT wheels of the vehicle with appropriate wheel chocks; making sure the vehicle's transmission is in 1<sup>st</sup> gear (manual) or "Park" (automatic).
3. Using a properly rated floor jack, lift the rear wheels of the vehicle off the ground. Place support stands, rated for the vehicle's weight, in the factory specified locations. Refer to the vehicle Owner's Manual. Prior to lowering the vehicle onto the stands, make sure the supports will securely contact the chassis.

It is very important that the vehicle is properly supported during this installation to prevent personal injury and chassis damage! Make sure that the supports stands are properly placed prior to performing the following procedures. We **DO NOT RECOMMEND** using wheel ramps while performing this installation.

4. Slowly lower the vehicle onto the stands and, before placing the vehicle's entire weight on them, again check that they properly and securely contact the chassis as described above. Check for possible interference with any lines, wires, cables, or other easily damaged components.

5. The new Belltech Anti-Sway Bar will attach to the bottom of the shock mounts with the bracket hardware. The Anti-Sway Bar end links will attach to the frame with a frame bracket (see photos 1-4).
6. Thoroughly lubricate the **inside** of the new polyurethane bushings using the grease provided. Locate the bushings on the ends of the Belltech Anti-Sway Bar (Photo 2, 3). Once located, rotate the bushings slightly too evenly spread the lubricant.

**WD-40™** is recommended to help remove excess lubricant. Re-greasing the pivot bushings should be performed at regular intervals. Climate and driving conditions will govern the time between services. Remember to check all hardware while performing bushing maintenance.

7. Insert the bar from under the vehicle positioning it under the axle with the bar ends pointed forward and angled up (Photo 1). Once in position, start from one side and place the bushing clamp directly to the backside of the shock mount, and loosely thread the hardware into place. Do the same to the other side (Photo 2, 3). **Do not** tighten the U-bolts, as they will be securely fastened after all the other components have been put on.
8. Next, you must install the Universal frame mount end link bracket hardware. To do this line up the end link holes of the Sway Bar, so the end links go straight down from the frame (photo 3) attach bracket with clamp, using a drill with a 3/8" socket drill in the self tapping screws into the frame, first the 3 on the side (photo 4). Release the clamp and drill the bottom two screws. Do the same for the end-link bracket on the opposite side.
9. When you have secured the bracket to the frame, then you can attach the end link with a 3/8-16 bolt and nut, then drop it down to the Sway Bar, and attach the last 3/8-16 bolt and nut.
10. Using a 9/16 socket, tighten and torque the bracket hardware to 19 lb ft. An open or closed end wrench may be required to access the bolt on the backside of the pivot-bushing bracket.

All hardware being fastened to the vehicle's original fastening points should be torqued to the proper specifications. To prevent chassis damage, never over-torque the hardware.

11. Check that all components and fasteners have been properly installed, tightened and torqued.
12. Check brake hoses, and other components for any possible interference.
13. Lift vehicle and remove support stands. Carefully lower vehicle to ground.
14. Immediately test-drive the vehicle in a remote location so that you can become accustomed to the revised driving characteristics and handling. Be aware that the vehicle will handle substantially different now that it has been modified.
15. Installation is complete. Check all of the hardware and re-torque at intervals for the first 10, 100, 1000 miles.

## PART LIST FOR 5555 ANTI-SWAY BAR

PART#	DESCRIPTION	QTY
5555-300	Anti/sway bar	1
114026	Pivot bushing bracket	2
114038	Under support plate	2
113085	Pivot bushing 1- 1/8"	2
112094	3/8"-16 x 1-1/4" HHCS	4
110255	3/8"-16 nylock nut	4
114050	End Link Dog Bone	2
112510	Flat washer 5/16"	8
5555-888	INSTRUCTIONS	1
55000-10	Grease pack	1
5501	UNIVERSAL FRAME MOUNT KIT	1

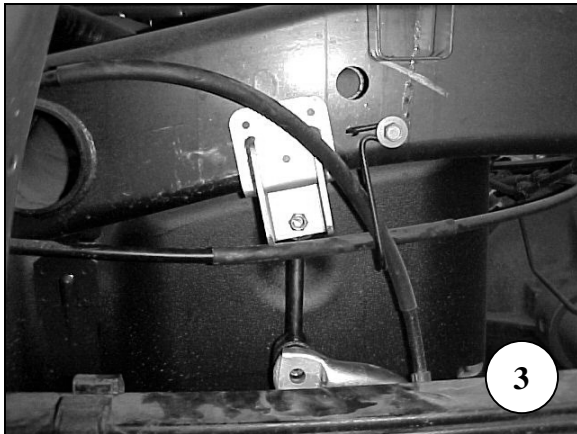
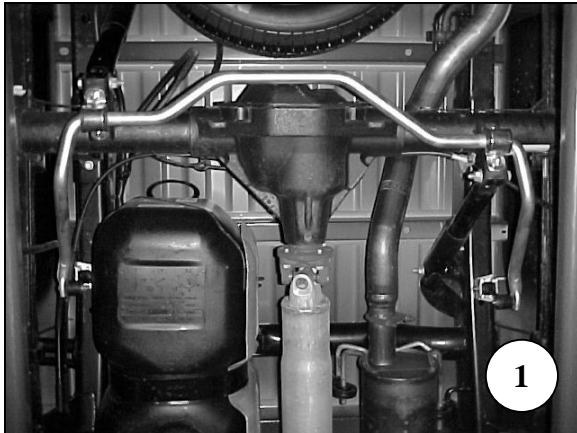

### **! BELLTECH INSTALLATION TIPS**

### **LUBRICATION**

Pre-lubricating the inside of the bushing before it's installed is important because the lubrication will greatly reduce noise and it will increase bushing life. Belltech recommends you use Molybdenum disulfide. This will help protect the inside surface of the bushing and will last longer than most types of grease. Thoroughly lubricate the inside of the bushing with this grease.

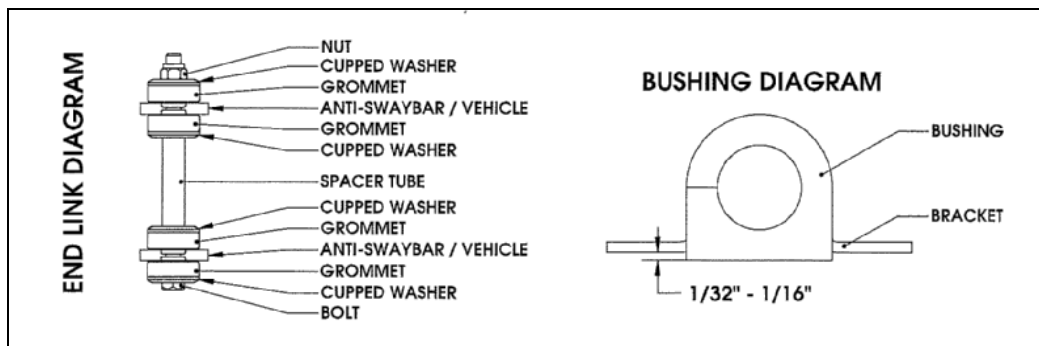

### **BUSHING INSTALLATION**

Make sure an amount of 1/32" to 1/16" of the bushing is showing when you install it onto the bracket. See the diagram above. If the bushing is showing more than 1/16" than use a sander or a sheet of coarse grit sand paper to shave it down to the proper height. In most applications when installing the new bushings on your Belltech Anti-Sway Bar you may refer to your original equipment Anti-Sway Bar to locate the proper location.

### **END-LINK INSTALLATION**

It is not required that you use lubricant on the end links since there is not any rotational movement. The Belltech end links are comprise of grommets, cupped washers, a spacer tube, bolt, and lock nut, these assembled components create the end link. See END LINK DIAGRAM above.

### **AXLE CLAMP DIAGRAM**

