



## INSTALLATION INSTRUCTIONS

1075 North Ave. Sanger, CA 93657-3539 local: 559-875-8883 fax: 559-875-9883 toll free: 800-595-7016

### 51045 '67-'69 CAMARO & FIREBIRD REAR ANTI-SWAYBAR

**Congratulations! You were selective enough to choose a SUSPENSION TECHNIQUES PRODUCT. We have spent many hours developing our line of products so that you will receive maximum performance with minimum difficulty during installation.**

- Note:** Confirm that all of the hardware listed in the parts list is in the kit. Do not begin installation if any part is missing. Read the instructions thoroughly before beginning this installation.
- Warning:** Do not work under a vehicle supported by only a jack. Place support stands securely under the vehicle in the manufacturer's specified locations unless otherwise instructed.
- Warning:** Do not drive vehicle until all work has been completed and checked. Torque all hardware to values specified.
- Reminder:** Proper use of safety equipment and eye/face/hand protection is absolutely necessary when using these tools to perform procedures!
- Note:** It is very helpful to have an assistant available during installation.

#### **RECOMMENDED TOOLS:**

- Properly rated floor jack, support stands, and wheel chocks
- Combination wrench set
- Ratcheting socket wrench and socket sets
- Safety Glasses

#### **KIT INSTALLATION**

1. Open the hardware kit and remove all of the contents. Refer to the part list (Page 2) to verify that all parts are present.
2. Park the vehicle on a smooth, level concrete or seasoned asphalt surface and activate the parking brake. Block the FRONT wheels of the vehicle with appropriate wheel chocks; making sure the vehicle's transmission is in 1<sup>st</sup> gear (manual) or "Park" (automatic).
3. Using a properly rated floor jack, lift the REAR wheels of the vehicle off the ground. Place support stands, rated for the vehicle's weight, and in the factory specified locations. Refer to the vehicle Owner's Manual. Prior to lowering the vehicle onto the stands, make sure the supports will securely contact the chassis.
4. It is very important that the vehicle is properly supported during this installation to prevent personal injury and chassis damage! Make sure that the supports stands are properly placed prior to performing the following procedures. We DO NOT recommend using wheel ramps while performing this installation.

5. Slowly lower the vehicle onto the stands and, before placing the vehicle's entire weight on them, again check that they properly and securely contact the chassis as described above. Check for possible interference with any lines, wires, cables, or other easily damaged components.
6. Thoroughly lubricate the **inside** of your new hyperthane bushings using a high grade lithium or silicone based grease with molybdenum disulfide (moly). Place the bushings on your new Suspension Techniques anti-swaybar as close to the outside arms as possible, just before the bend
7. Place the U-bolts over the top of the axle. Make sure the brake line is out of the way. Place the mounting brackets over the bushings and mount the anti-swaybar. Secure the anti-swaybar with a washer and nylock nut supplied in the kit.
8. Line the arms of the anti-swaybar an even distance between the frame rails. Attach the end link assemblies to the arms. Refer to the diagram for proper sequence.
9. Hold the arms horizontal with the frame and use the angle bracket as a guide to mark the frame rails for drilling. Drill a 1/2-inch hole through each frame rail where you marked.
10. Remove the angle bracket from the end link assembly and mount the short leg of it to the frame rail. Use 1/2-inch washers on the outside of the rail. Reattach the end link to the anti-swaybar and angle bracket as you did in step 4.
11. Check that all components and fasteners have been properly installed, tightened and torqued.
12. Check brake hoses, steering and other components for any possible interference.
13. Lift vehicle and remove support stands. Carefully lower vehicle to ground.
14. Immediately test-drive the vehicle in a remote location so that you can become accustomed to the revised driving characteristics and handling. Be aware that the vehicle will handle substantially different now that it has been modified.
15. Installation is complete. Check all of the hardware and re-torque at intervals for the first 10, 100, 1000 miles.

## PARTS LIST

### '67-'69 CAMARO & FIREBIRD REAR ANTI-SWAYBAR

1	51045-300	REAR ANTI-SWAYBAR
2	113205	BUSHINGS
8	113000	ENLINK GROMMETS
2	114032	BUSHING BRACKETS
2	51105-005	ANGLE BRACKETS
2	114038	FLAT PLATES
2	112130	3/8" - 16 x 5-1/2" HHCS
6	110255	3/8" - 16 NYLOCK NUTS
2	112212	1/2" - 13 x 3 1/2" HHCS

2	110660	1/2" SAE WASHER
2	112322	1/2" - 13 NYLOCK NUT
8	112502	CUPPED WASHERS
4	110625	3/8" SAE WASHERS
2	112258	U-CLAMPS
2	112538	1/2" USS WASHER
2	112406	1-1/4" SPACER TUBES
1	55000-10	GREASE PACK

## **! Installation Tips ST**

- **Lubrication**

Pre-lubricating the inside of the bushing before its installed is important because the lubrication will greatly reduce noise and it will increase bushing life. Suspension Techniques recommends you use Molybdenum disulfide. This will help protect the inside surface of the bushing and will last longer than most types of grease. Thoroughly lubricate the inside of the bushing with this grease.

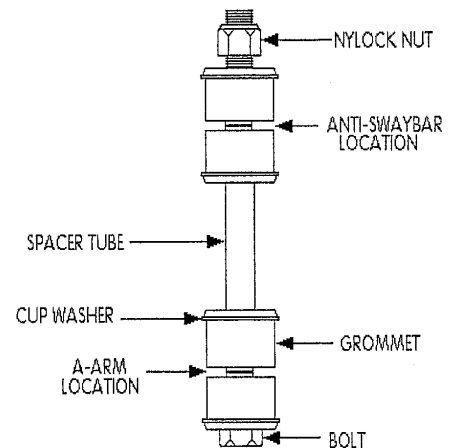
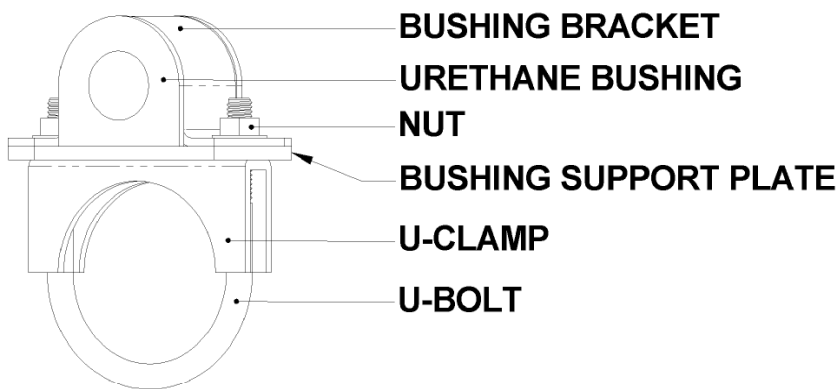

- **Bushing Installation**

Make sure an amount of 1/32" to 1/16" of the bushing is showing when you install it onto the bracket. See the diagram above. If the bushing is showing more than 1/16" than use a sander or a sheet of coarse grit sand paper to shave it down to the proper height. In most applications when installing the new bushings on your Suspension Techniques anti-sway bar you may refer to your original equipment anti-sway bar to locate the proper location.

- **End Link Installation**

It is not required that you use lubricant on the end links since there is no rotational movement. The Suspension Techniques end links are comprise of grommets, cupped washers, a spacer tube, bolt, and lock nut, these assembled components create the end link. See end link diagram.

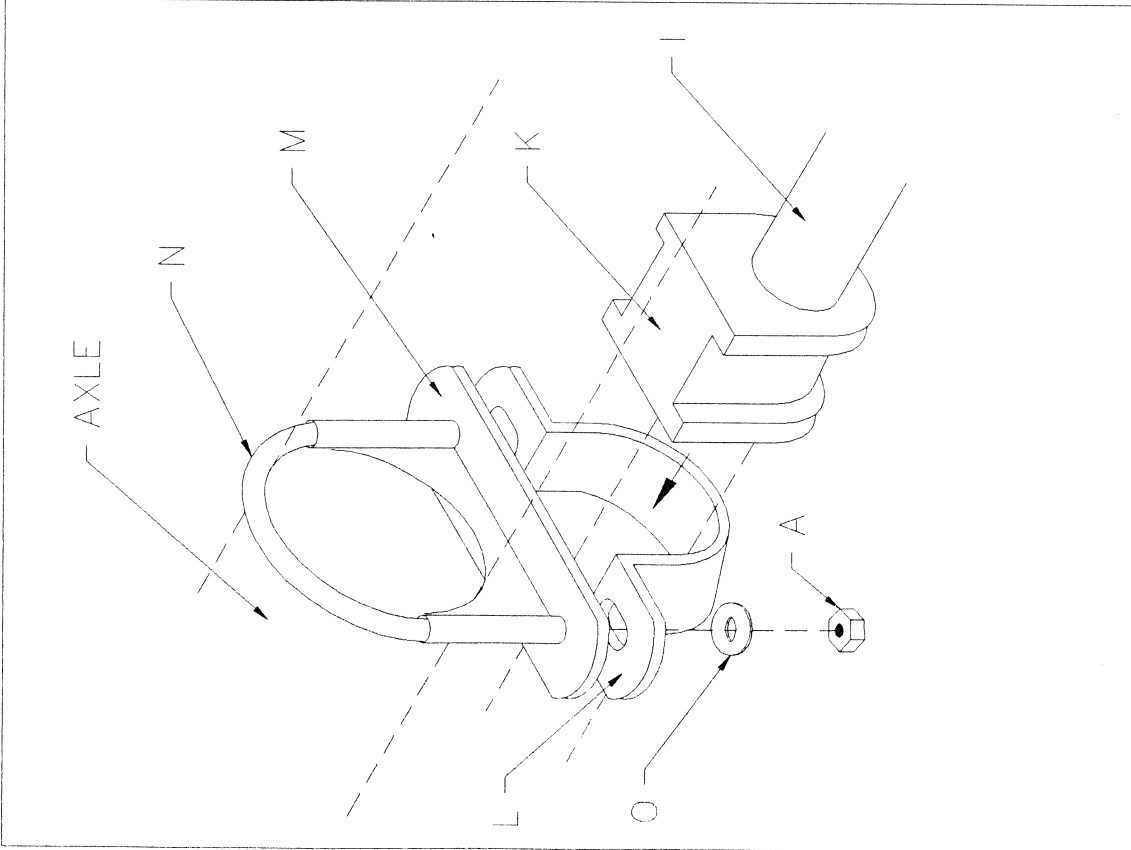

- A - 3/8" NYLOCK NUT
- B - 3 1/2" x 1/2" HEX HEAD CAP SCREW
- C - 1/2" USS WASHER
- D - 2" x 2" FLAT PLATE
- E - END LINK GROMMET
- F - CUP WASHER
- G - 5 1/2" x 3/8" HEX HEAD CAP SCREW
- H - END LINK SPACER

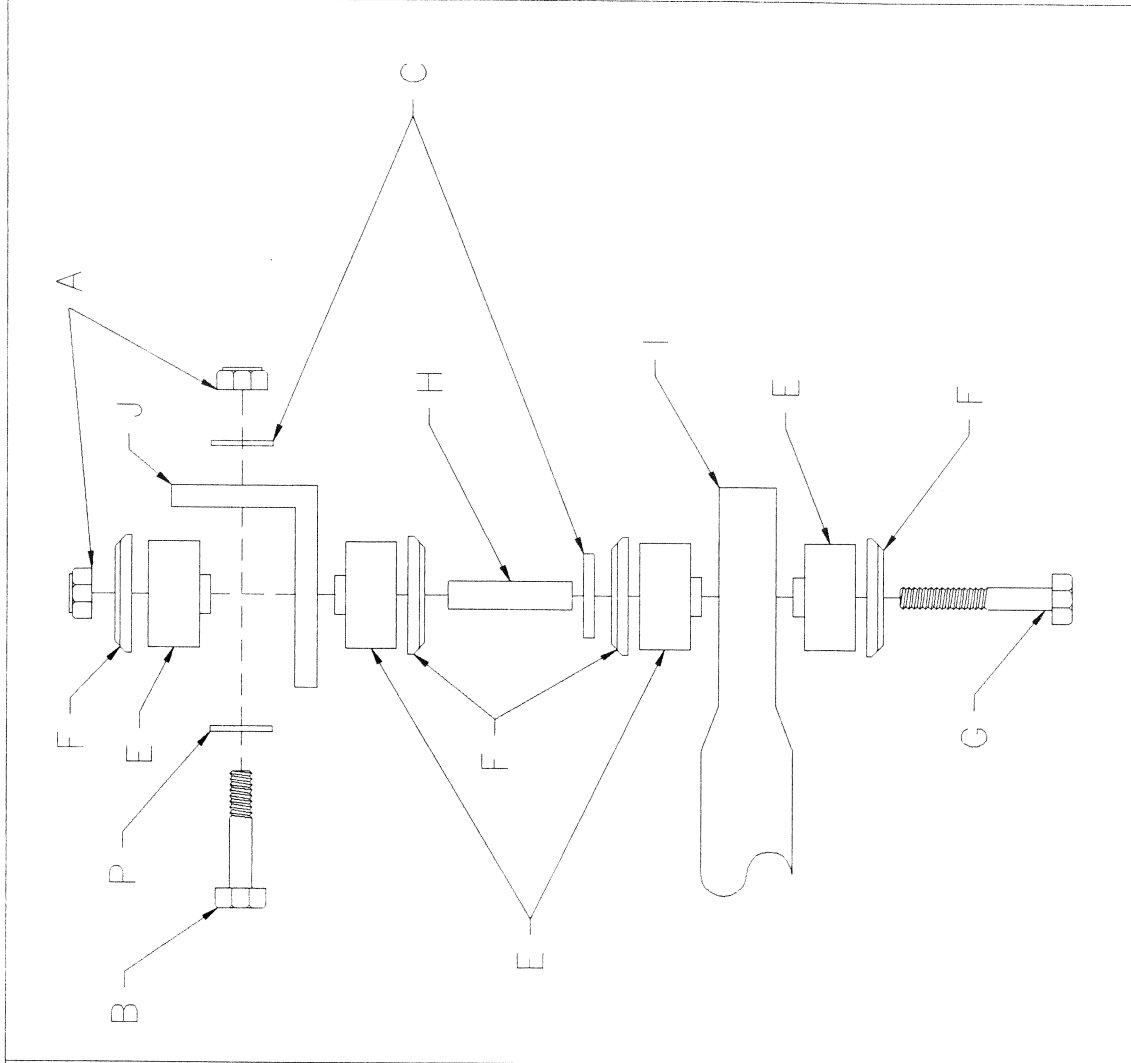

- I - ANTI-SWAYBAR
- J - ANGLE BRACKET
- K - PIVOT BUSHING
- L - SWAYBAR BRACKET
- M - BUSHING SUPPORT PLATE
- N - 'U' BRACKET WITH SADDLE
- O - 3/8" SAE WASHER
- P - 1/2" SAE WASHER