



SUPERLIFT®

S U S P E N S I O N

Superlift Dual Steering Stabilizer System On or After March 01, 2008 and Newer 3/4- and 1-ton Dodge Ram 4WD INSTALLATION INSTRUCTIONS

INTRODUCTION

Installation requires a professional mechanic. Prior to beginning, inspect the vehicles steering, driveline, and brake systems, paying close attention to the suspension link arms and bushings, anti-sway bars and bushings, tie rod ends, pitman arm, ball joints and wheel bearings. Also check the steering sector-to-frame and all suspension-to-frame attaching points for stress cracks. The overall vehicle must be in excellent working condition; repair or replace all worn parts.

Read instructions several times before starting. Be sure you have all needed parts and know where they install. Read each step completely as you go.

NOTES:

- **DO NOT INSTALL ON DODGE 2500 VEHICLES EQUIPPED WITH EXTREME RING.** Installing dual steering stabilizer will interfere with the extreme ring, prematurely stopping the steering cycle, which could result in steering component failure.
- An arrow on diagrams indicates which direction is toward the front of the vehicle.
- A foot-pound torque reading is given in parenthesis () after each appropriate fastener.
- Do not fabricate any components to gain additional suspension height.
- Prior to drilling or cutting, check behind the surface being worked on for any components that could be damaged.
- After drilling, file smooth any burrs and sharp edges.
- Prior to operating a torch or saw, protect any heat-sensitive components located in the immediate area by covering them with a water-saturated cloth. Most undercoating are flammable but can be extinguished using a water-filled spray bottle. Have a spray bottle and an ABC rated fire extinguisher on hand.
- Paint or undercoat all exposed metal surfaces.
- Prior to attaching components, be sure all mating surfaces are free of grit, grease, undercoating, etc.
- A factory service manual should be on hand for reference.
- Use the check-off box "☐" found at each step to help you keep your place. Two "☐☐" denotes that one check-off box is for the driver side and one is for the passenger side. Unless otherwise noted, always start with the driver side.

PARTS LIST ... The part number is stamped into each part or printed on an adhesive label. Identify each part and place the appropriate mounting hardware with it.

PART NO	DESCRIPTION (Qty.- if more than one)	NEW ATTACHING HARDWARE (Qty.)
55-01-92708.....	driver side bracket	(1) 1/2" shock stud pack (2) 3/8" x 1" bolt (2) 3/8" nyloc nut
55-02-92708	passenger side bracket	(1) 1/2" shock stud pack (2) 3/8" x 1" bolt (2) 3/8" nyloc nut
55-03-92708	center bracket.....	(2) 5/16" x 1-1/4" x 3" U-bolt (4) 5/16" flange nut (2) 1/2" x 2-1/2" bolt (2) 1/2" stover nut (2) 1/2" USS flat washer (2) 5/8" OD x 1/2" ID x 1-1/2" sleeve
Part number.....	(2) steering stabilizer	(2) shock boot*
depends kit ordered		(2) hardware pack and cable tie

***(Note: Shock boots, if desired, purchased separately)**

0034..... Superlift badge alcohol wipe pad

00461..... decal, "Warning To Driver"

INSTALLATION PROCEDURE

- 1) PREPARE VEHICLE...**
 - Place vehicle in Park and engage parking brake. Position the steering wheel so that the tires are pointed straight ahead.
- 2) REMOVE FACTORY COMPONENTS...**
 - Remove and discard the factory steering stabilizer, if equipped.
 - [DIAGRAM 1] Using a cut-off wheel or similar tool, remove the factory steering stabilizer mount tabs as shown. After cutting, file smooth any rough edges.
- 3) INSTALL STABILIZER BRACKETRY...**
 - [DIAGRAM 2] On each side, install the 1/2" stabilizer mounting studs, lock washer

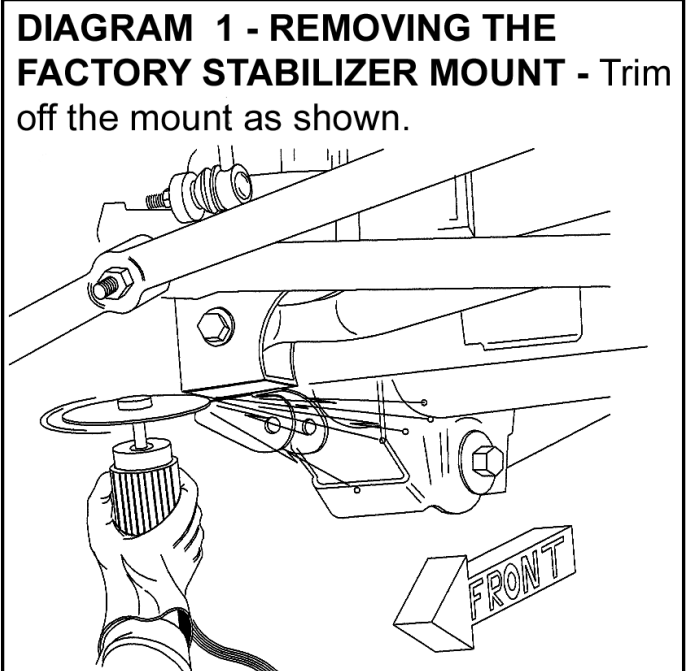

and nut on the #55-01-92670 driver side and #55-02-92670 passenger side brackets as shown. Tighten (57).

- ☐☐ [DIAGRAM 2] On each side, position the #55-01-92670 driver side and #55-02-92670 passenger side brackets inside the lower link arm axle brackets as shown. The brackets should be positioned so that the shock studs are offset to the outside of the vehicle (towards the tires) as shown. Clamp the “01” and “02” brackets in place.

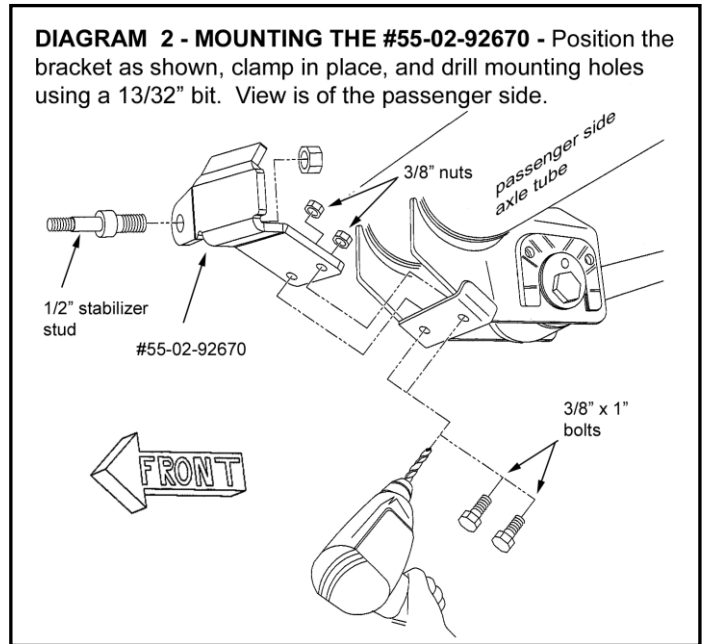

- ☐☐ **Prior to 2009:** on each side, using the two holes in the factory lower link axle brackets as a template, drill two holes in the “01” and “02” brackets using a 13/32 inch drill bit.

- ☐☐ **On 2009 models:** measure from the center of the hole in the factory lower link axle brackets to either side 7/8 inch and drill two holes in the factory brackets as well as the “01” and “02” brackets using a 13/32 inch drill bit.

- ☐☐ Install the supplied 3/8 inch x 1 inch bolts and nyloc nuts through the holes drilled previously and tighten (30).

- ☐☐ Install the supplied 1/2 inch x 2-1/2 inch Bolts through the 55-03-92708 before the “03” is in place.

- ☐ [DIAGRAM 4] Install the two supplied 5/16 inch U-bolts on each side of the “03” bracket as shown. The “03” bracket must be positioned in the middle of the flat surface on the tie rod. Secure using the supplied 5/16 inch flange nuts. Tighten (20).

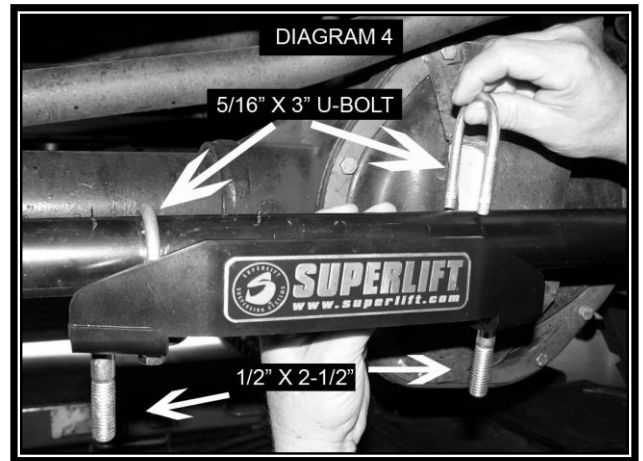

4) INSTALL #81160 STEERING STABILIZERS...

- ☐☐ If the optional shock boots have been purchased, install now and secure with the supplied zip ties.

- ☐☐ Install the supplied 5/8 inch OD x 1.5 inch long sleeves in the bushings on the rod ends of each #81160 steering stabilizer.

- ☐ [DIAGRAM 4 & 5] Assemble the #55-03-92670 bracket, steering stabilizers, and 1/2 inch x 2-1/2 inch bolts as shown. Note that the rod end of each stabilizer attaches to the 1/2 inch x 2-1/2 inch bolts in the “03” bracket; the opposite end attaches to the studs on the “01” and “02” brackets.

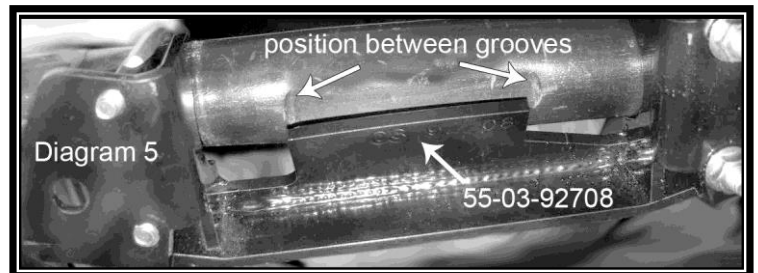

- Loosely secure the stud ends with the supplied 1/2" standard nuts and 1/2" x 2-1/2" bolts with the supplied 1/2" stover nuts and USS flat washers.
- Tighten the rod ends of the stabilizers until the bushings swell slightly, followed by the opposite ends of each stabilizer (57).

5) FINAL PROCEDURES...

- Cycle the steering lock-to-lock and check clearance between the stabilizer bodies and the tie rod / drag link assembly. Pay close attention to ensure each stabilizer is not bottoming or topping out throughout the steering cycle.
- Check all hardware for adequate torque and clearance.
- Check the steering, suspension, and brake systems for proper operation, tightness, and adequate clearance.

Limited Lifetime Warranty / Warnings

Your Superlift® product is covered by the Limited Warranty explained below that gives you specific legal rights. This limited warranty is the only warranty Superlift® makes in connection with your product purchase. Superlift® neither assumes nor authorizes any retailer or other person or entity to assume for it any other obligation or liability in connection with this product or limited warranty.

What is covered? Subject to the terms below, Superlift® will repair or replace its products found defective in materials or workmanship for so long as the original purchaser owns the vehicle on which the product was originally installed. Your warrantor is LKI Enterprises, Inc. d/b/a Superlift® Suspension Systems ("Superlift®").

What is not covered? Your Superlift® Limited Warranty does not cover products, parts or vehicles Superlift® determines to have been damaged by or subjected to:

- Alteration, modification or failure to maintain.
- Normal wear and tear (bushings, tie-rod ends, etc.). Scratches or defects in product finishes (powdercoating, plating, etc.),
- Damage to or resulting from vehicle's electronic stability system, related components or other vehicle systems.
- Racing or other vehicle competitions or contests. Accidents, impact by rocks, trees, obstacles or other aspects of the environment.
- Theft, vandalism or other intentional damage.

Remedy Limited to Repair / Replacement. The exclusive remedy provided hereunder shall, upon Superlift's inspection and at Superlift's option, be either repair or replacement of product or parts covered under this Limited Warranty. Customers requesting warranty consideration should contact Superlift® by phone (1-800-551-4955) to obtain a Returned Goods Authorization number. All removal, shipping and installation costs are customer's responsibility.

If a replacement part is needed before the Superlift® part in question can be returned, you must first purchase the replacement part. Then, if the part in question is deemed warrantable, you will be credited / refunded.

Other Limitations - Exclusion of Damages - Your Rights Under State Law

- Neither Superlift® nor your independent Superlift® dealer are responsible for any time loss, rental costs, or for any incidental, consequential or other damages you may have.

- This Limited Warranty gives you specific rights. You may also have other rights that vary from state to state. For example, while all implied warranties are disclaimed herein, any implied warranty required by law is limited to the terms of our Limited Lifetime Warranty as described above. Some states do not allow limitations of how long an implied warranty lasts and / or do not allow the exclusion or limitation of incidental or consequential damages, so the limitations and exclusions herein may not apply to you.

Important Product Use and Safety Information / Warnings

As a general rule, the taller a vehicle is, the easier it will roll over. Offset, as much as possible, what is lost in rollover resistance by increasing tire track width. In other words, go “wide” as you go “tall”. Many sportsmen remove their mud tires after hunting season and install ones more appropriate for street driving; always use as wide a tire and wheel combination as feasible to enhance vehicle stability. We strongly recommend, because of rollover possibility, that the vehicle be equipped with a functional roll bar and cage system. Seat belts and shoulder harnesses should be worn at all times. Avoid situations where a side rollover may occur.

Generally, braking performance and capabilities are decreased when significantly larger / heavier tires and wheels are used. Take this into consideration while driving. Also, changing axle gear ratios or using tires that are taller or shorter than factory height will cause an erroneous speedometer reading. On vehicles equipped with an electronic speedometer, the speed signal impacts other important functions as well. Speedometer recalibration for both mechanical and electronic types is highly recommended.

Do not add, alter, or fabricate any factory or aftermarket parts to increase vehicle height over the intended height of the Superlift product purchased. Mixing component brands is not recommended.

All Superlift® material is copyrighted. All images found in this catalog and in any Superlift® marketing forums are the sole property of or licensed to Superlift®. Any reproduction of said materials, in part or in whole, with out the express written permission of Superlift® is strictly forbidden. Superlift®, Rockrunner™, Swamprunner™, Superide™, Superide SS™ and SSR™, Black Diamond®, XCL™, X2™ Super Trac™, Torque Max™, Torque Max SS™, eXtreme Ring™, Rail Wrap™, Bullet Proof Brake Hose™, TruSpeed™, Frame Integrated Technology™, F.I.T. Series™ and Rock Fink™ are registered trademarks of Superlift® Suspension Systems. Superlift® Suspension Systems is a Division of Bret Lovett's Lift Kits Incorporated.

SUPERLIFT SUSPENSION SYSTEMS

300 Huey Lenard Loop Rd.
West Monroe, Louisiana 71292
Phone: (318) 397-3000
Sales / Tech: 1-800-551-4955
FAX: (318) 397-3040
www.superlift.com