



MAHINDRA 2018-21 Roxor 5" Lift Kit

Thank you for choosing Rough Country for all your vehicle needs.

Rough Country recommends a certified technician install this system. In addition to these instructions, professional knowledge of disassemble/reassembly procedures as well as post installation checks must be known. Attempts to install this system without this knowledge and expertise may jeopardize the integrity and/or operating safety of the vehicle.

Please read instructions before beginning installation. Check the kit hardware against the parts list. Be sure you have all needed parts and know where they go. Also please review tools needed list and make sure you have needed tools.

If question exist, please call us @1-800-222-7023. We will be happy to answer any questions concerning this product. Check all fasteners for proper torque. Check to ensure for adequate clearance between all components. Periodically check all hardware for tightness.

PRODUCT USE INFORMATION

⚠ WARNING As a general rule, the taller a vehicle is, the easier it will roll. We strongly recommend, because of rollover possibility that seat belts and shoulder harnesses should be worn at all times. Avoid situations where a side rollover may occur.

Generally, braking performance and capability are decreased when larger/heavier tires and wheels are used. Take this into consideration while driving. Do not add, alter, or fabricate any factory or after-market parts to increase vehicle height over the intended height of the Rough Country product purchased. Mixing component brands is not recommended.

Rough Country makes no claims regarding lifting devices and excludes any and all implied claims. We will not be responsible for any product that is altered. If questions exist we will be happy to answer them concerning the design, function, and correct use of our products.

The 5" suspension system was developed using a 33x12.50-15 tire with 15 x 10 wheel with 4" backspace and -38mm offset. . When using a stock wheel the maximum tire width is 11 1/2". The lifts were designed to lift the front to level the vehicle. Due to manufacturing, dimension variances, and inflation all tire and wheel combinations should be tested prior to installation on all oversized / wider then stock tires We recommend a wheel not exceeding 8" in width be used with a minimum backspacing of 4.5" to a maximum of 5".

NOTICE TO DEALER AND VEHICLE OWNER

⚠ NOTICE Any vehicle equipped with any Rough Country product should have a "Warning to Driver" decal installed on the inside of the windshield or on the vehicle's dash. The decal should act as a constant reminder for whoever is operating the vehicle of its unique handling characteristics.

Torque Specs:

Size	Grade 5	Grade 8	Size	Class 8.8	Class 10.9
5/16"	15 ft/lbs	20ft/lbs	6MM	5ft/lbs	9ft/lbs
3/8"	30 ft/lbs	35ft/lbs	8MM	18ft/lbs	23ft/lbs
7/16"	45 ft/lbs	60ft/lbs	10MM	32ft/lbs	45ft/lbs
1/2"	65 ft/lbs	90ft/lbs	12MM	55ft/lbs	75ft/lbs
9/16"	95 ft/lbs	130ft/lbs	14MM	85ft/lbs	120ft/lbs
5/8"	135ft/lbs	175ft/lbs	16MM	130ft/lbs	165ft/lbs
3/4"	185ft/lbs	280ft/lbs	18MM	170ft/lbs	240ft/lbs



Kit Contents:

Front Driver Axle Bracket x1
Front Pass Axle Bracket x1
Front Dr Side and Both Rear U-bolt Plates x3
Front Pass Side U-bolt Plate x1
Front Extended Brake Line x2
Rear Axle Bracket x2
Rear Brake Line Drop x2
Steering Stabilizer Bracket x1
Bump Stop Bracket x4
Bump Stop x4
Pitman Arm x1
Shocks x4
Steering Stabilizer x1

Tools Needed:

13mm Socket/Wrench
16mm Socket/Wrench
17mm Socket/Wrench
18mm Socket/Wrench
19mm Socket/Wrench
21mm Socket/Wrench
24mm Socket/Wrench
36mm Socket/Wrench
13/32" Drill Bit
9/16" Drill Bit
5/8" Drill Bit
Hammer
Pitman arm Puller

Hardware Included:

9/16" x 2-1/2 x 8-1/2" U-Bolts x4
9/16" x 2-1/2 x 7-3/4" U-Bolts x4
9/16" Flat Washer x16
9/16"-18 Nylock Nut x16
5/16" x 1-1/4 x 2" U-Bolts x2
5/16" x 1 x 1-5/8" U-Bolts x2
5/16"-18 Flange Nut x4
1/4" Vent Hose x1
3/8"-16x1" Bolt x8
3/8"-16 Nut x8
3/8" Flat Washer x12
3/8" Lock Washer x8
8MM-1.25x25MM Bolt x2
8MM-1.25 Nylock Flange Nut x2
8MM Flat Washer x4

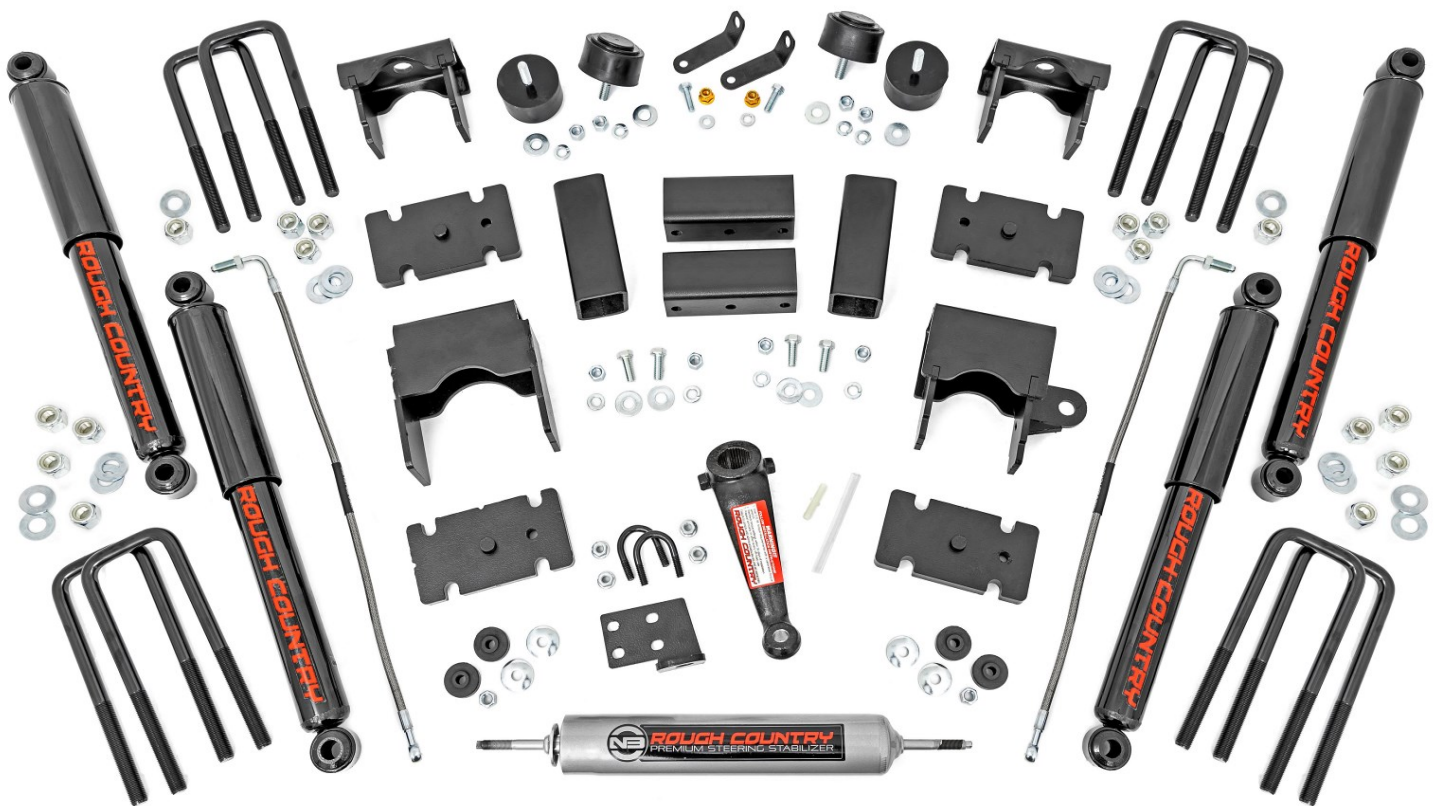

FRONT INSTALLATION INSTRUCTONS

1. Jack up the front of the vehicle and place on jack stands.
2. Remove the front wheels. Remove the differential vent tube from the diff.
3. Remove the lower nut for the swaybar link using a 18MM socket/wrench. **See Photo 1.**
4. Remove the upper nut and bolt for the swaybar link using a 18MM socket/wrench. **See Photo 2.**

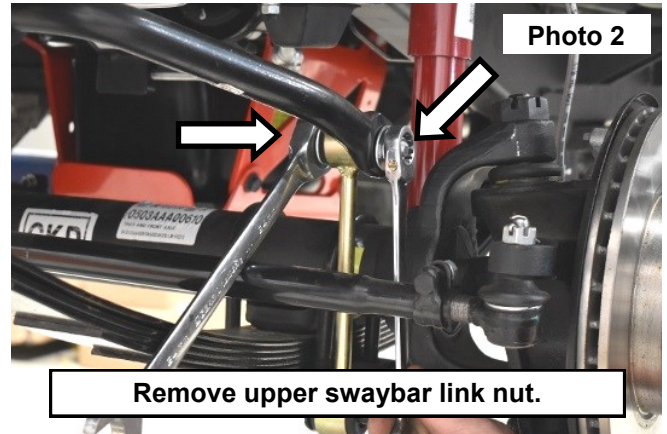
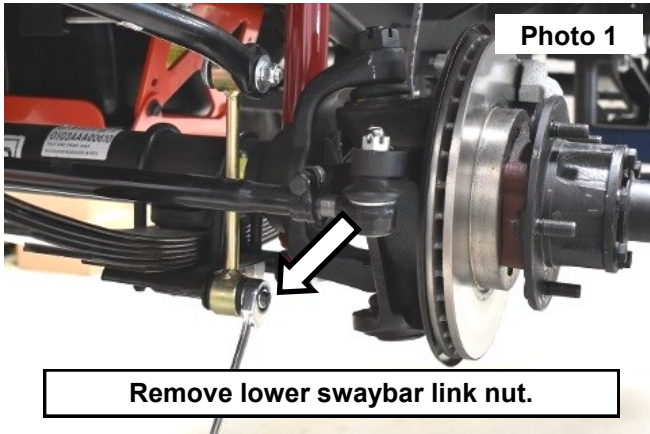

5. Remove the upper shock nut using a 24MM socket/wrench. **See Photo 3.**
6. Remove the lower shock nut using a 24MM socket/wrench. **See Photo 4.**

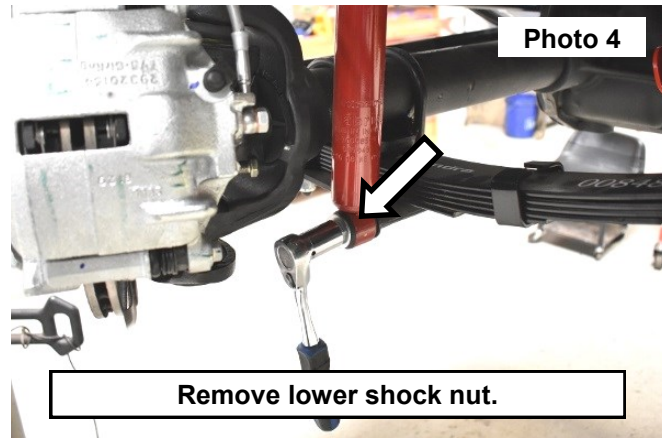
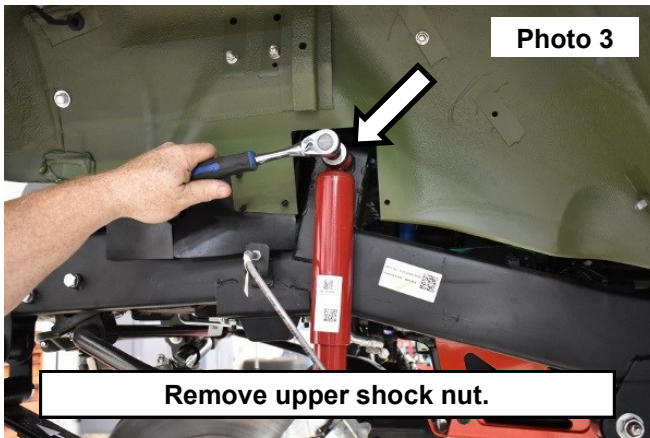

7. Remove the shock. **See Photo 5.**
8. Loosen (NOT remove) the front bolt for the leaf spring using a 24mm socket/wrench. **See Photo 6.**

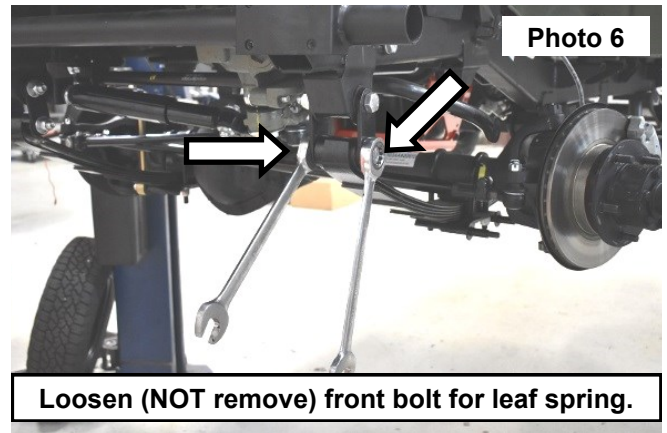

9. Remove the U-bolt nuts using a 19MM socket/wrench. **See Photo 7.**
10. Remove the U-bolt plate. **See Photo 8.**

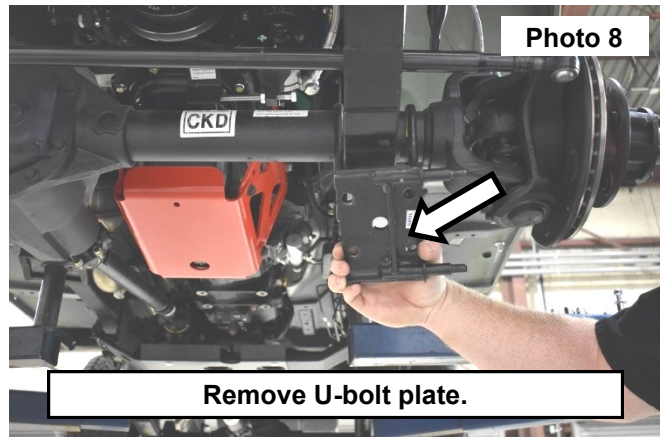
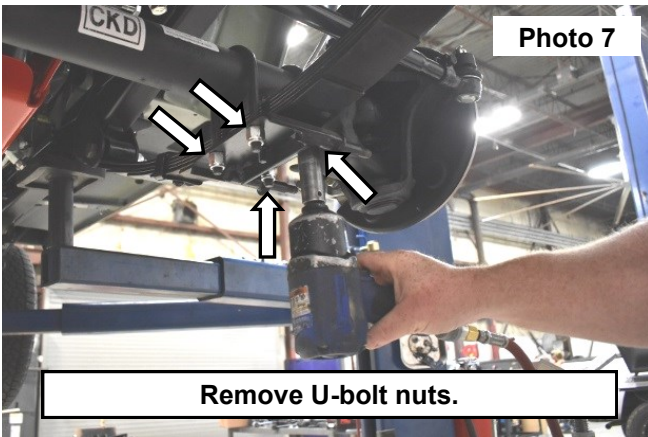

11. Loosen (NOT remove) the rear bolt for the leaf spring using a 24mm socket/wrench. **See Photo 9.**
12. Support axle and remove the front bolt for the leaf spring and lower spring.
NOTE: Be sure to support axle with jack stands before removing the leaf spring.
See Photo 10.

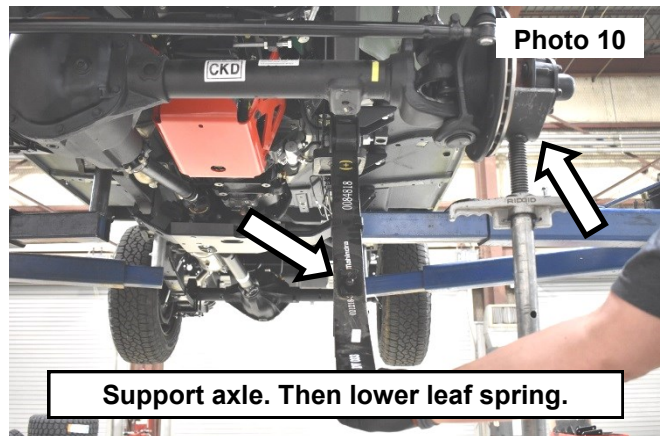
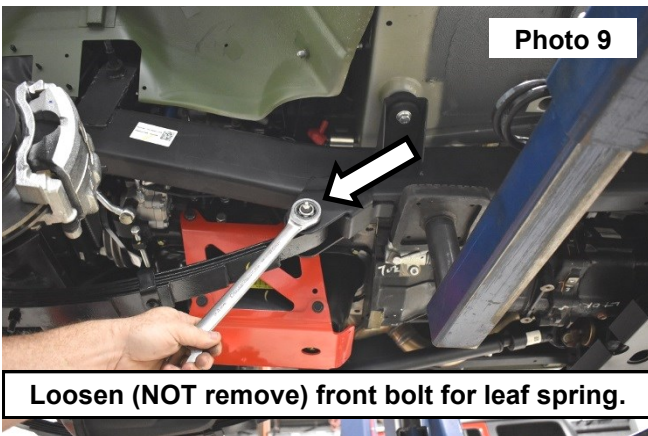

13. Remove the rear bolt for the leaf spring. **See Photo 11.**
14. Take note of the Driver and Pass Axle Brackets. **See Photo 12.**

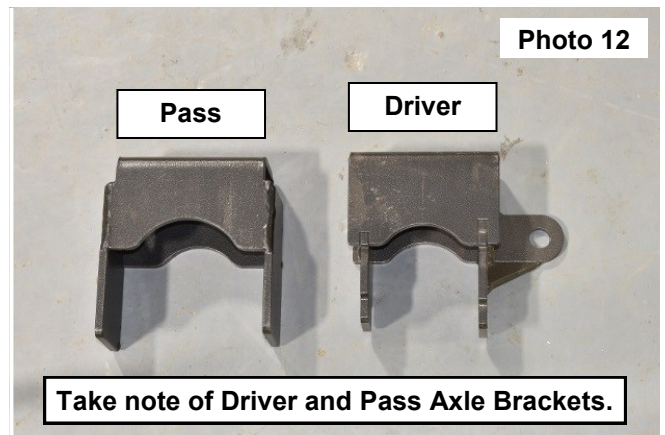
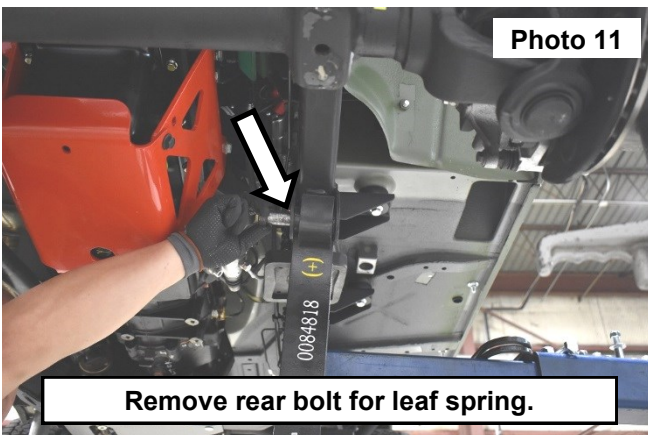

15. Install the brackets to the appropriate sides and install leaf springs in the stock location but make sure they are above the brackets. **Do NOT fully tighten at this point. Will tighten at the end. See Photo 13.**
NOTE: For Driver side bracket, the extension with the hole faces the front of the vehicle. For the Pass side bracket, the larger radius curve goes towards the inside of the vehicle.
16. Drill a larger hole in the axle center pin hole using a 9/16" drill bit. **See Photo 14.**

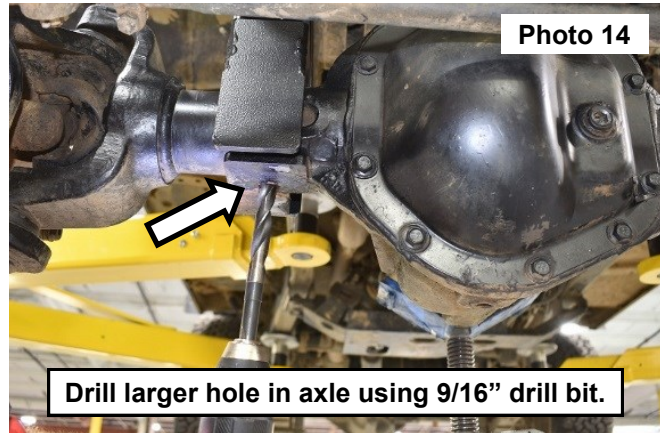
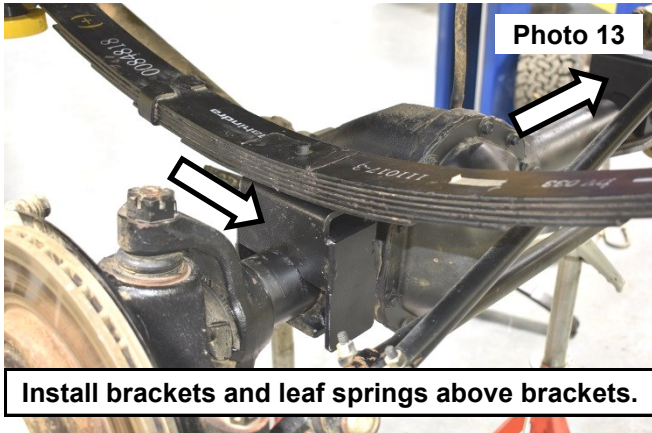

17. Take note of the supplied Driver and Pass side U-bolt plates. **See Photo 15.**
18. Drill a larger hole in the U-bolt plates using a 5/8" drill bit. **See Photo 16.**

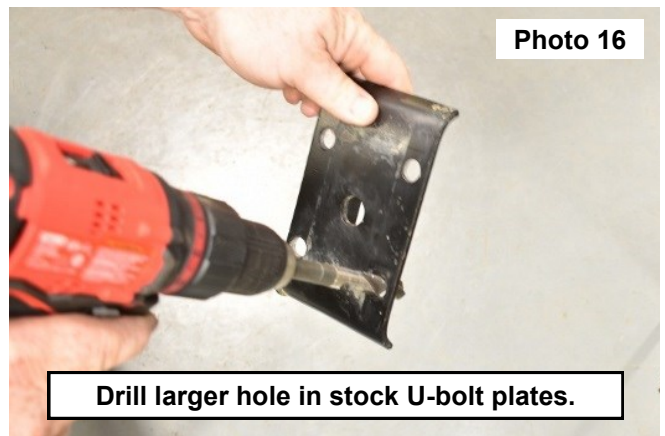
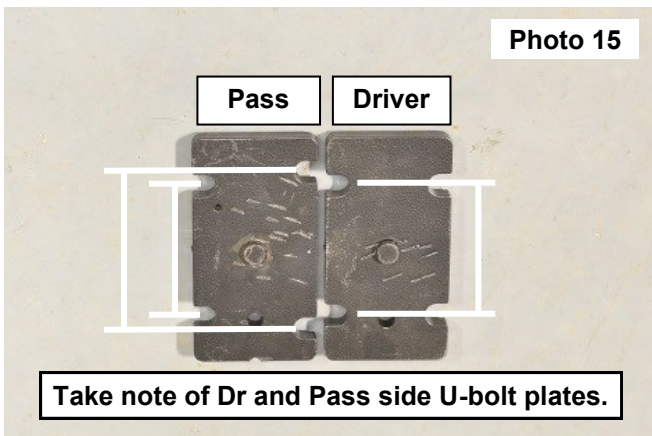

19. Install the U-bolts and both the stock and supplied U-bolt plates. Install stock plates above the leaf springs and the supplied plates beneath the axle. **See Photo 17.**
20. **NOTE: For the supplied Pass side U-bolt plate, the further spaced side faces the differential. See Photo 18.**

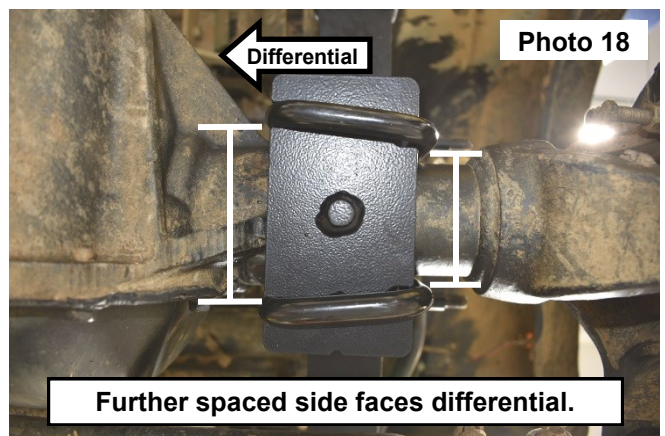
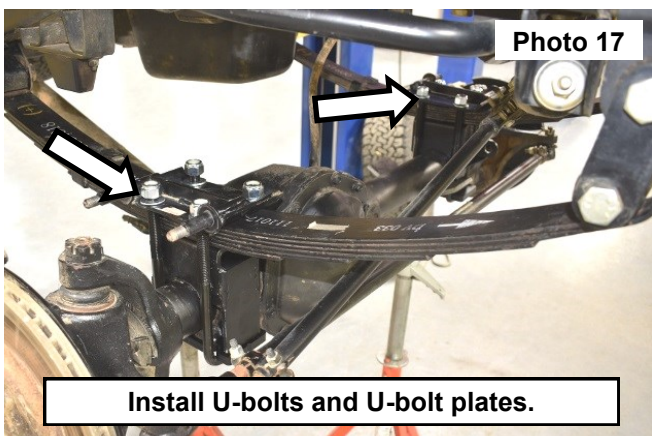

21. Remove the cotter pin and drag link castle nut using a 19mm socket/wrench to disconnect the drag link from the pitman arm. Strike the washer securing the pitman arm nut using a hammer and blunt punch. **See Photo 19.**
22. Remove pitman arm nut using a 36mm socket/wrench. Remove washer. **See Photo 20.**

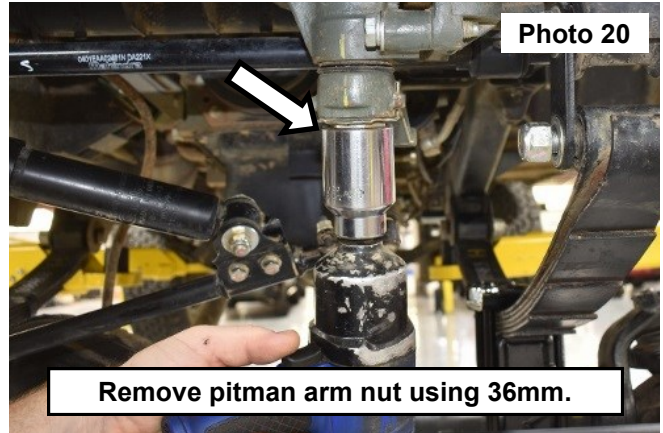
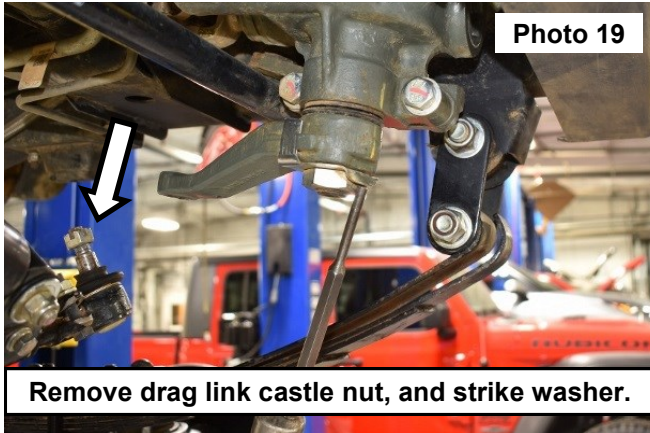

23. Use a pitman arm puller to remove the stock pitman arm. **See Photo 21.**
24. Install the supplied pitman arm. **See Photo 22.**

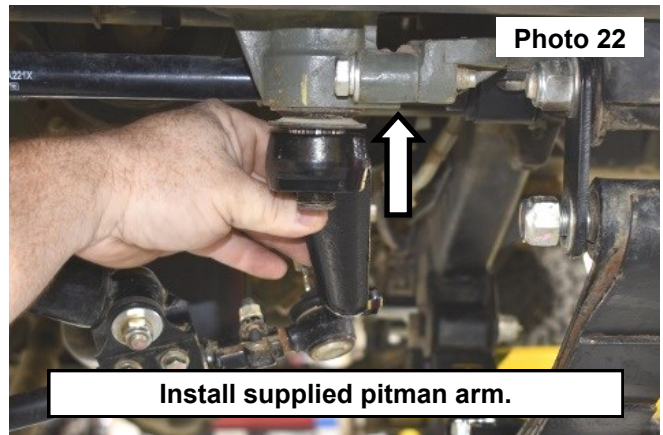
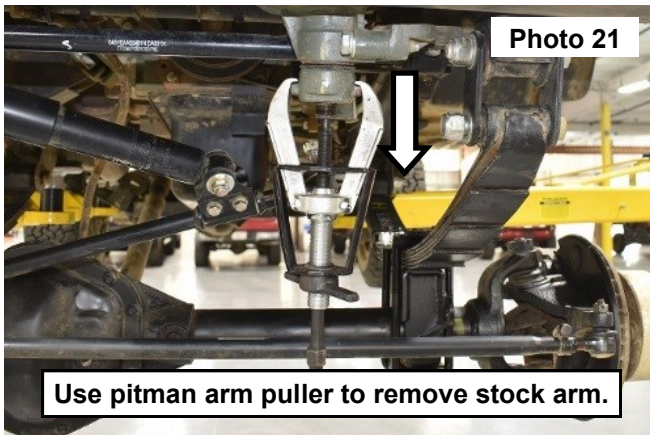

25. Install the stock pitman arm washer and nut a 36mm socket/wrench. **See Photo 23.**
26. Strike the washer tab with a hammer to secure the pitman arm nut. **See Photo 24.**

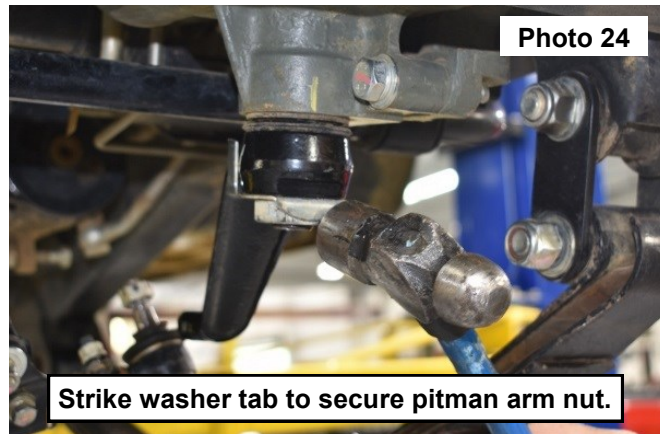

27. Install the drag link to the pitman arm and secure with stock castle nut and cotter pin. **See Photo 25.**
28. Install shock and swaybar link using stock hardware. **See Photo 26.**

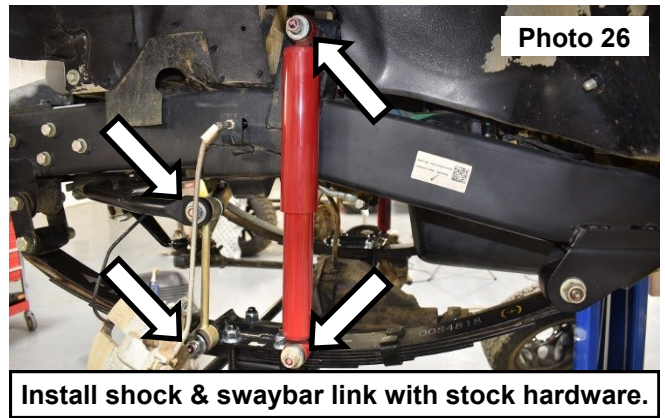
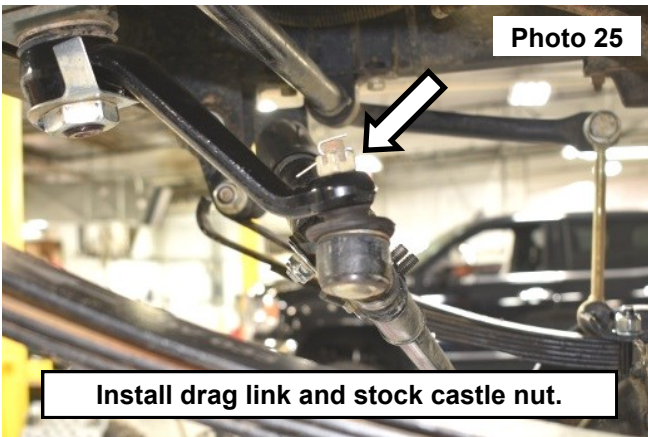

29. Remove the bump stop using a 13mm socket/wrench. **See Photo 27.**
30. Install supplied bump stop using stock hardware. **See Photo 28.**

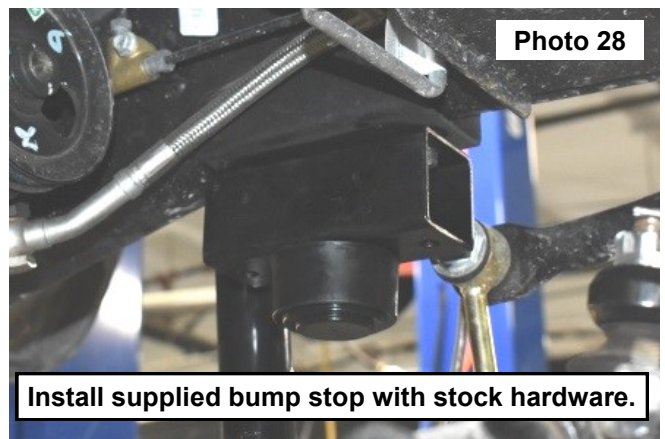
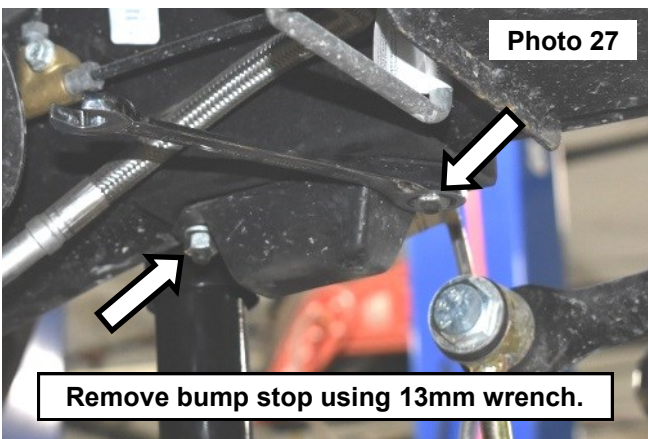

31. Remove the caliper end of the brake line using a 16mm wrench. **See Photo 29.**
32. Remove the threaded end of the brake line using a 13mm wrench. **See Photo 30.**

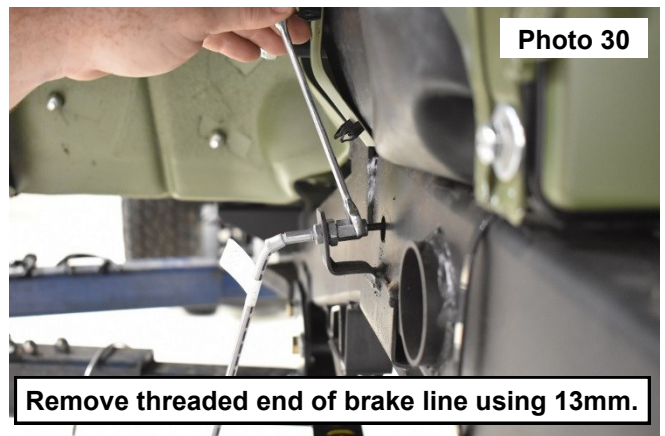
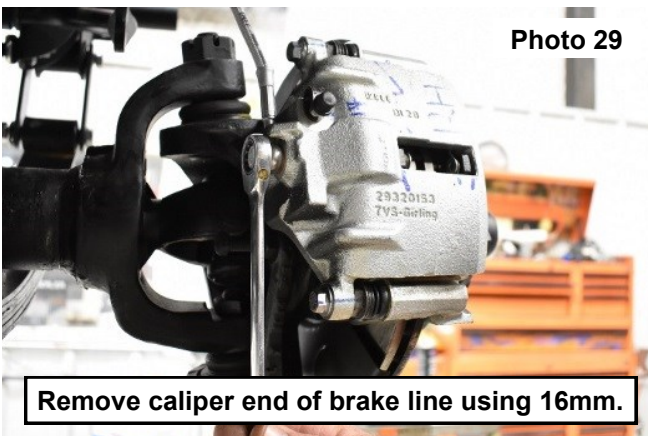

33. Install the supplied extended brake line in the stock location using the stock hardware.

▲ NOTICE NOTE: You will need to bleed the brake line when installing the extended brake line.

34. Install the differential vent tube extension on the diff.
35. Put on wheels and lower vehicle.
36. Tighten leaf spring bolts once the vehicle is on the ground.



STEERING STABILIZER INSTALLATION INSTRUCTIONS

1. Remove the stock steering stabilizer at the frame using a 16mm socket/wrench. **See Photo 1.**
2. Remove the stock steering stabilizer at the drag link bracket using a 17mm socket/wrench. **See Photo 2.**

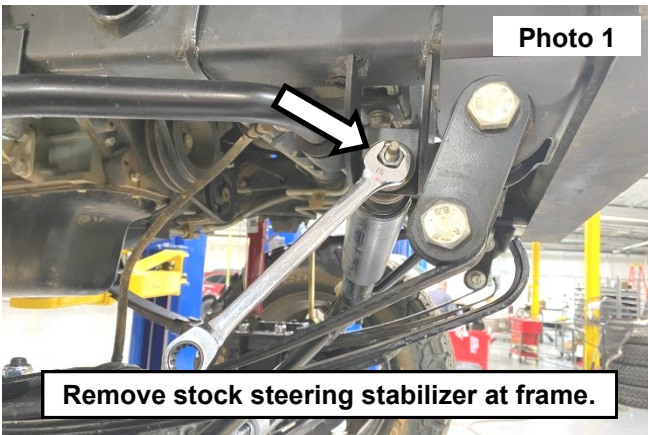

3. Remove the steering stabilizer drag link bracket using a 13mm socket/wrench. **See Photo 3.**
4. Install the supplied steering stabilizer in the driver side axle bracket using a 9/16" socket/wrench. **See Photo 4.**

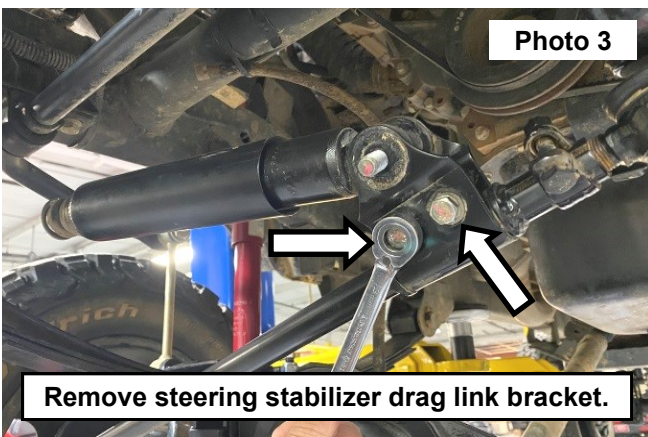

5. Install the stabilizer tie rod bracket on the stabilizer and then the tie rod using the supplied 5/16" U-Bolts and flange nuts using a 13mm stock/wrench. **See Photo 5 and Photo 6.**

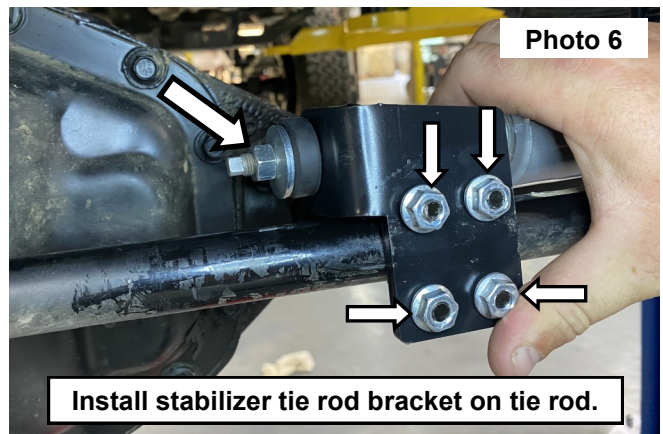
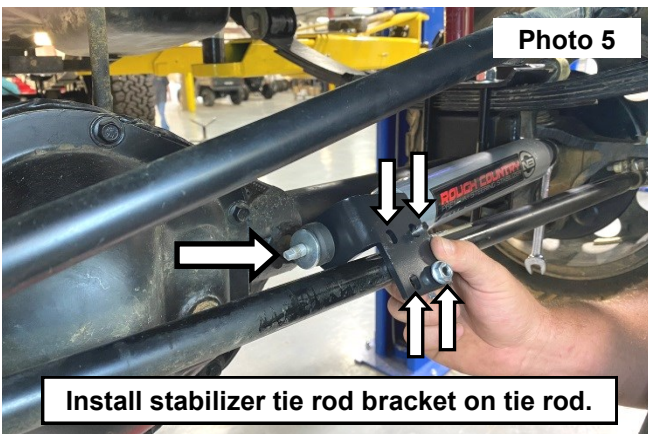

6. **NOTE:** If the steering stabilizer rubs the tie rod when you swing the steering wheel from stop to stop, repeat the following steps until the stabilizer does not rub:
- a. Swing the steering wheel all the way to the drivers side. **See Photo 7.**
 - b. Check to make sure the stabilizer is not touching the tie rod. Rotate the bracket as needed. **See Photo 8.**

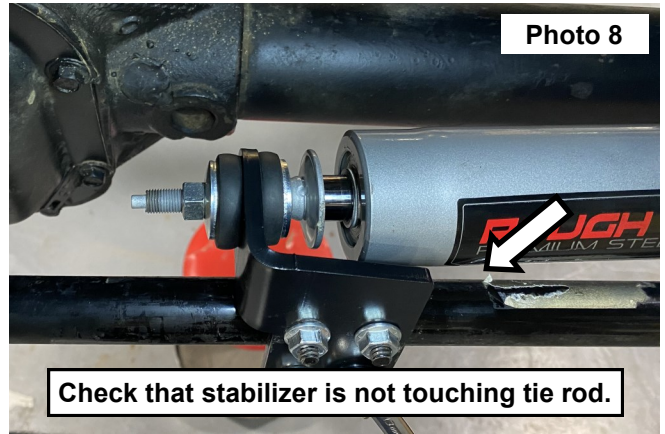

- c. Swing the steering wheel all the way to the passenger side. **See Photo 9.**
- d. Check to make sure the stabilizer is not touching the differential. Rotate the bracket as needed. **See Photo 10.**

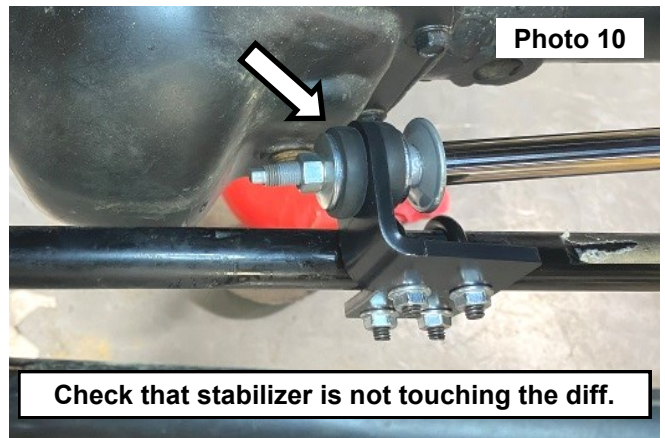
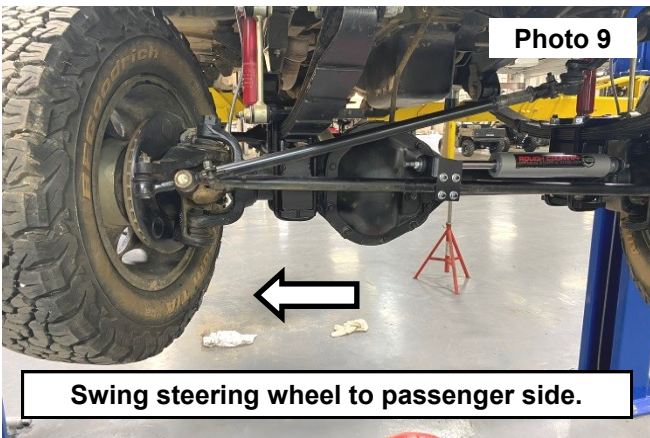

REAR INSTALLATION INSTRUCTONS

1. Jack up the rear of the vehicle and place on jack stands.
2. Remove the rear wheels.
3. Remove the rear shocks using an 18mm socket/wrench. **See Photo 1.**
4. Remove the emergency brake line from frame using a 13mm socket/wrench. **See Photo 2.**

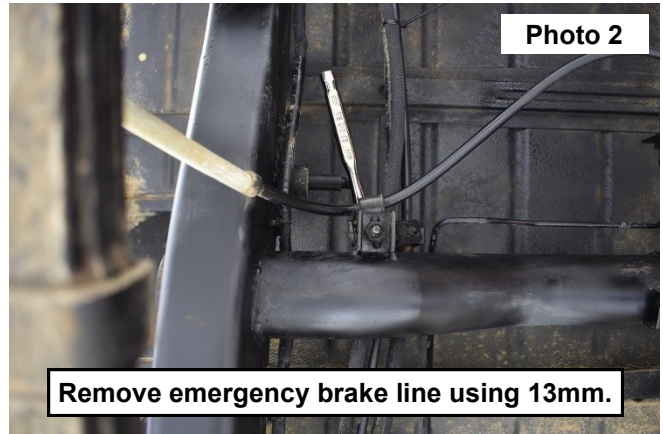
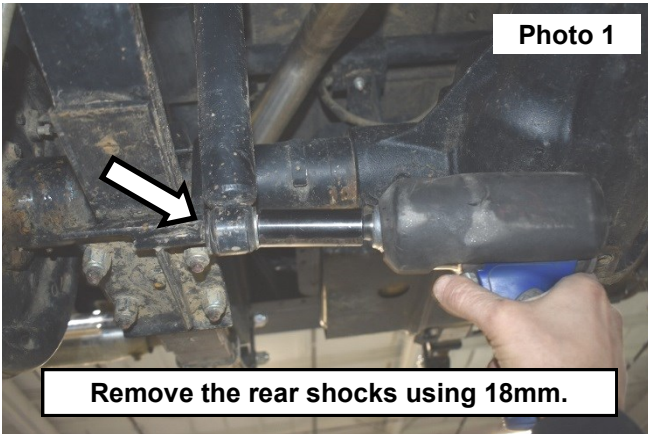

5. Support the rear axle and remove the rear U-bolts using a 19mm socket/wrench. **See Photo 3.**
6. Remove the leaf springs and shackles using a 24mm socket/wrench. **See Photo 4.**

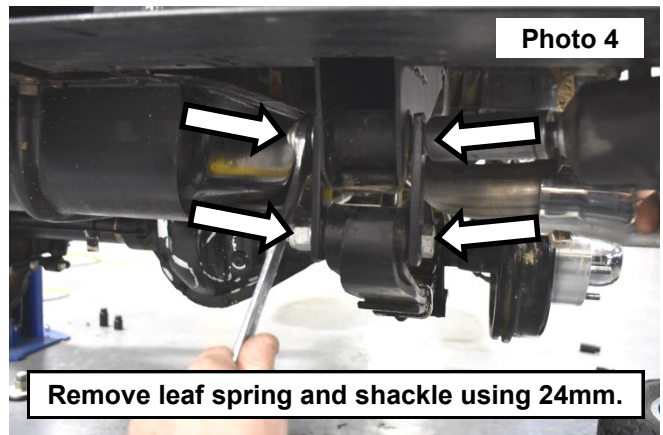
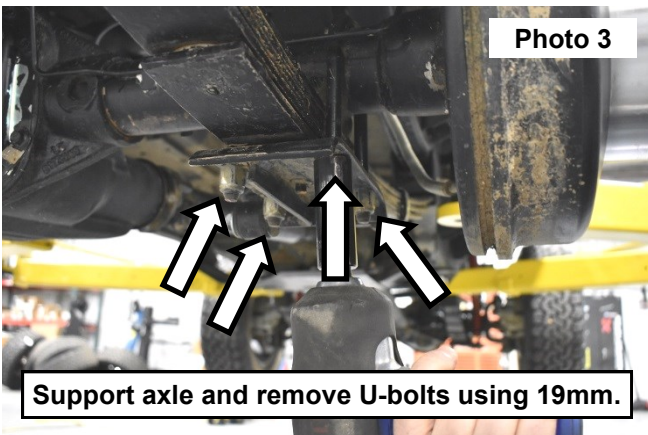

7. Install the blocks over the axle with the shorter side toward the rear. **See Photo 5.**
8. Drill the axle center pin hole using a 9/16" drill bit. **See Photo 6.**

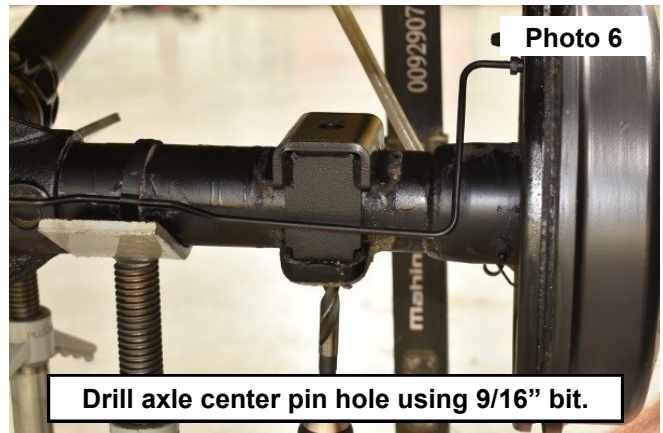
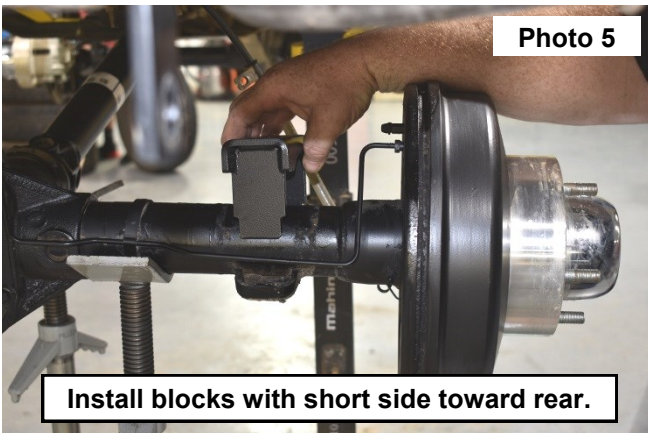

9. Drill the stock U-bolt plate holes using a 5/8" bit.
10. Install the leaf springs in the stock location above the axle.
11. Install the driver stock U-bolt plate on the passenger side and vice versa with the other side. Install the supplied U-bolt plates and U-bolts below the axle.
Secure with the supplied 9/16"-18 nuts and washers. Tighten using a 21mm socket/wrench. **See Photo 7.**
12. Install the brake line drop bracket using the supplied 8mm bolts, nuts, and washers. Tighten using a 13mm socket/wrench. **See Photo 8.**

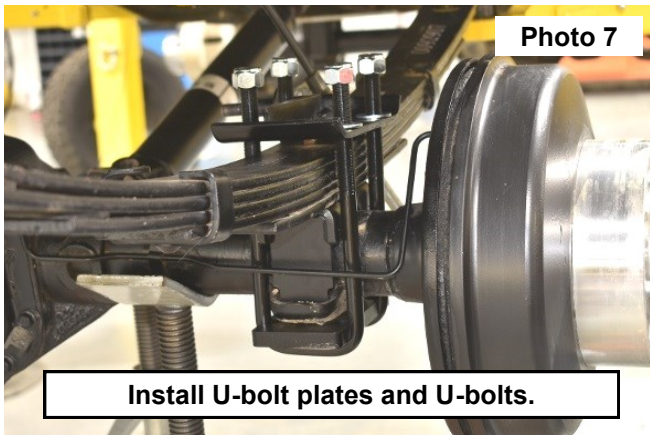

Install U-bolt plates and U-bolts.

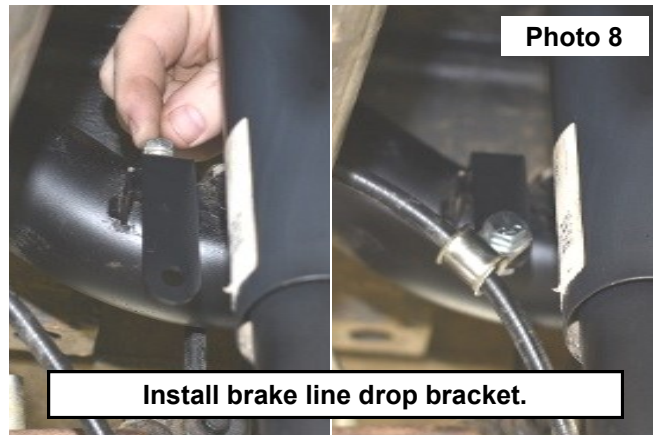

Install brake line drop bracket.

13. Align the bump stop brackets and mark the holes with a paint pen. **See Photo 9.**
14. Drill holes using a 13/32" drill bit. **See Photo 10.**



Align bump stop bracket and mark holes.

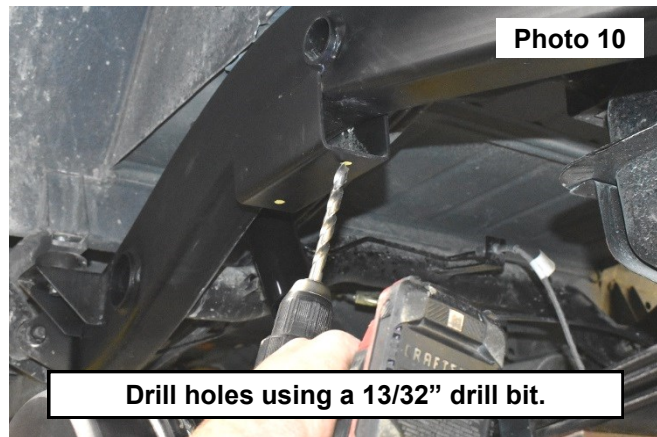

Drill holes using a 13/32" drill bit.

15. Install the bump stop to the bump stop bracket. **See Photo 11.**
16. Install the bump stop bracket using the supplied 3/8" bolts, nuts and washers. Tighten using a 9/16" socket/wrench. **See Photo 12.**

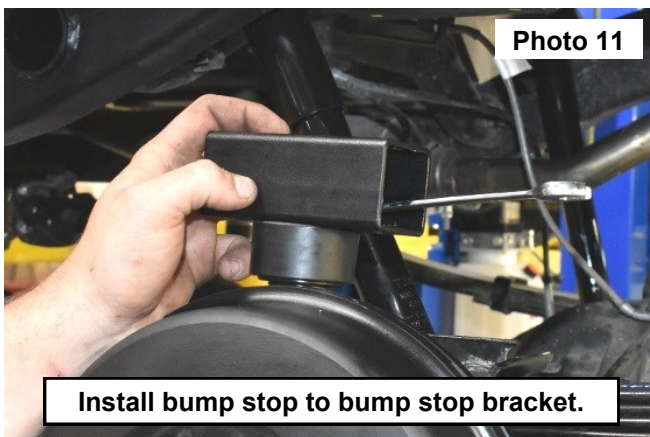

Install bump stop to bump stop bracket.

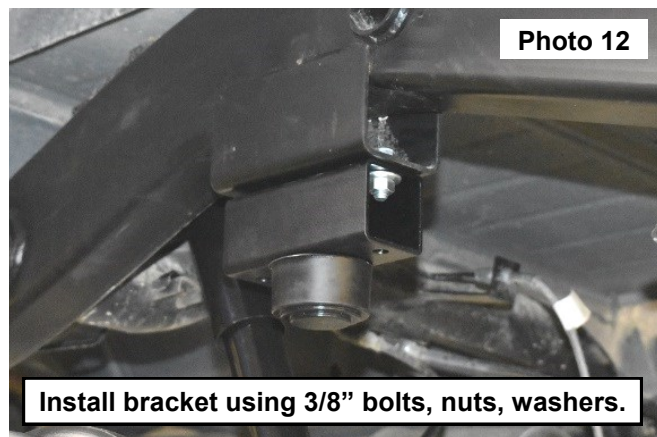

Install bracket using 3/8" bolts, nuts, washers.

17. Install the shocks.
18. Install the wheels and lower.



By purchasing any item sold by Rough Country, LLC, the buyer expressly warrants that he/she is in compliance with all applicable, State, and Local laws and regulations regarding the purchase, ownership, and use of the item. It shall be the buyers responsibility to comply with all Federal, State and Local laws governing the sales of any items listed, illustrated or sold. The buyer expressly agrees to indemnify and hold harmless Rough Country, LLC for all claims resulting directly or indirectly from the purchase, ownership, or use of the items.



