



# INSTALLATION INSTRUCTIONS

26022  
REAR LIFT STRUT

300 W. Pontiac Way Clovis, CA 93612 toll free: 1-800-445-3767 web: www.belltech.com

## 2021+ GM SUV 4WD 0-2" LIFT STRUT

Thank you for being selective enough to choose our high quality BELLTECH PRODUCT. We have spent many hours developing our line of products so that you will receive maximum performance with minimum difficulty during installation

Note: Confirm that all of the hardware listed in the parts list is in the kit. **Do not** begin installation if any part is missing. Read the instructions thoroughly before beginning this installation.

**Warning: DO NOT** work under a vehicle supported by only a jack. Place support stands securely under the vehicle in the manufacturer’s specified locations unless otherwise instructed.

**Warning: DO NOT** drive vehicle until all work has been completed and checked. Torque all hardware to specified values.

Reminder: Proper use of safety equipment and eye/face/hand protection is absolutely necessary when using these tools to perform procedures!

Note: It is very helpful to have an assistant available during installation.

### Exceptional Customer Experience Guarantee:

**STOP!** We strive for an exceptional experience for all of our valued customers. If, for any reason, you need assistance with your Belltech products, please do not return the products to the store or website you purchased from. Please call our dedicated experts at

(1-800-445-3767) from 7am to 5pm PST.

### RECOMMENDED TOOLS

- Properly rated floor jack and support stands
- Combination wrench set
- Ratcheting socket wrench and socket set
- Safety glasses
- Torque wrench
- Wheel chocks
- Tape measure
- Marking pen
- Spring Compressor



DIFFICULTY:



INSTALLATION TIME: 2-4hrs + Alignment

**KIT INSTALLATION**

**WE RECOMMEND** that a qualified mechanic, at a properly equipped facility, perform this installation.

**WE RECOMMEND** that the installation be performed on a firm, flat, and level surface such as seasoned asphalt or concrete.

**The use of safe and proper equipment is very important!**

**KIT PRERPERATION**

- a) Before beginning the install process, measure the hub to fender heights for your vehicle so you can compare the resulting height to the original. Measure vertically from the center of the wheel to the inner edge of the fender. Record results here.

LF: \_\_\_\_\_ RF: \_\_\_\_\_

LR: \_\_\_\_\_ RR: \_\_\_\_\_

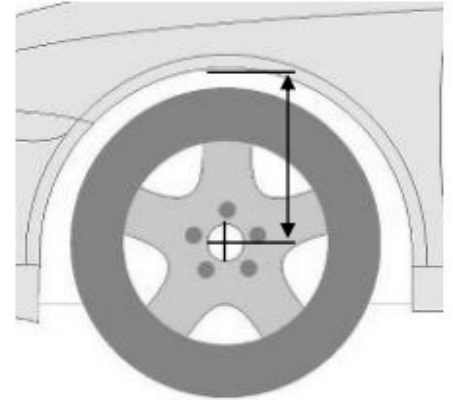
**1) JACKING, SUPPORTING AND PREPARING THE VEHICLE**

- a) Block the rear wheels of the vehicle with appropriate wheel chocks. Make sure the vehicle's transmission is in "PARK" (automatic) or 1st gear (manual). Activate the parking brake.
- b) Loosen, but **DO NOT REMOVE** the front wheel lug nuts.
- c) Lift the front of the vehicle off the ground using properly rated floor jack. Lift the vehicle so that the front tires are approximately 6-8 inches off the ground surface.
- d) Place support stands rated for the vehicles weight. The stands should be positioned in the factory specified locations. (Refer to owners manual). Prior to lowering the vehicle onto stands, make sure the support stands will contact the chassis. It is very important that the vehicle is properly supported to prevent any harm to ones self or to the vehicle.
- e) Lower the vehicle slowly onto the stands, checking that they properly and securely contacting the frame rails as described above before placing the vehicles weight completely on them.
- f) Remove the front wheels.

**!SAFETY REMINDER!**

**Check for safe vehicle stability before proceeding under the vehicle to begin the following procedures. Never work under a vehicle supported by **ONLY** a jack. Always use properly rated support stands to support the vehicle.**

## 2) OEM Strut Removal

- Remove the bolt holding the lower strut to the lower control arm. **(Photo 1)**
- Remove the 2 brake line bolts and 1 lower control arm bolt attaching the control arm to the spindle. **(Photo 1)**
- Remove the 3 flanged nuts securing the top of the strut to the chassis. **(Photo 2)**
- Push the lower control arm down until the lower strut is able to clear the control arm.
- Drop the old strut out of the strut tower. **(Photo 3)**

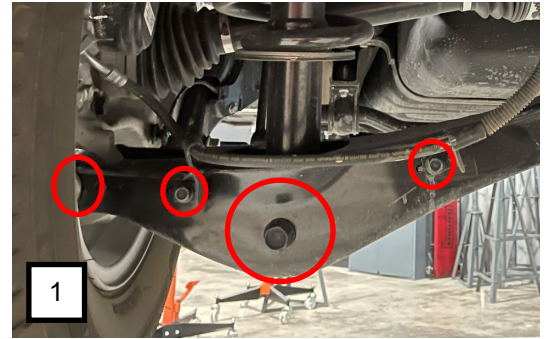

## 3) OEM Strut Disassembly

**!Caution! The coil spring is held in place under extreme compression. Belltech recommends the use of a heavy duty spring compressor suitable for truck springs to perform the following steps. If unsure of your spring compressor capabilities, take your struts to a professional installer. Use caution during the following steps to avoid personal injury and/or damage to the vehicle.**

- Mark the orientation of the strut top mount relative to the strut body.
- Mount the spring/strut assembly into a spring compressor and compress the spring to alleviate the tension on the strut **(Photo 4)**
- Remove **(DO NOT USE AN IMPACT)** the strut top nut from the assembly. The strut will need to be supported as when the nut is removed the strut will fall.
- Remove the shock and bump stop from the assembly. You will reuse the OEM top mount, dust boot, rubber isolator, and the spring. **(Photo 5)**



#### 4) Strut Setup/Assembly

- a) Using the table below, put the specified rings onto the Belltech leveling strut. If a half inch increment is desired, add one 10mm ring from the next lowest leveling height. For example, if a 1.5" lift is desired, add a 10mm ring from the 1" lift for a total of 1 x 10mm ring and 2 x 16mm rings.

Vehicle Height Table			
Item Description	OE	1" Lift	2" Lift
10mm Ring	0	2	1
16mm Ring	0	0	2
15mm Packer	0	1	1
25mm Packer	0	0	1

- b) Transfer plastic lower spring isolator from OE perch to the new Belltech perch. Place the spring perch on top of the ring stack. **(Photo 6)**
- c) Slide on the vent disk and the specified packers using the vehicle height table.
- d) Slide the bump stop onto the strut ensuring that the flat part is facing away from the bottom spring perch.
- e) With the OEM spring still compressed, slide the strut back into the spring and put the strut top mount back on and torque the nut to OE specifications.

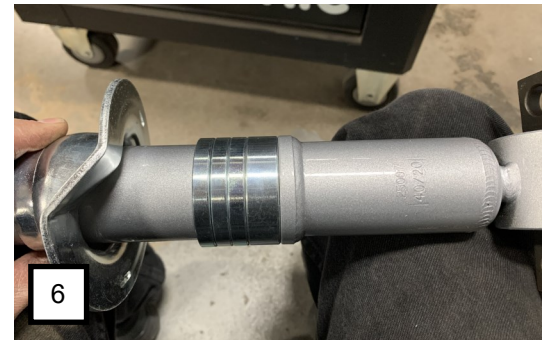

#### 5) Belltech Strut Installation

- a) Install the Belltech strut into the frame strut tower in reverse order as removal and secure the top mount with the OEM flanged nuts and torque to factory specifications. **(Photo 7)**
- b) Reattach the lower control arm to the spindle and the brake line brackets to the lower control arm in reverse order of removal. **(Photo 8)**
- c) Attach the lower strut mount to the lower control arm in reverse order as removal using the OE hardware. Torque to factory specifications. **(Photo 8)**

## 5) Finalizing the Installation

- a) Re-install the wheels and torque to OEM specifications.
- b) Check that all components and fasteners have been properly installed and torqued.
- c) Lift the vehicle and remove the support stands. Carefully lower the vehicle to the ground.
- d) Check brake hoses, cables, and other components for possible interference.
- e) Check for wheel/tire to chassis/body interference.
- f) Test-drive the vehicle in a remote location so that you can be accustomed to the revised driving characteristics and handling. Be aware that the vehicle will handle substantially different.
- g) Check all of the hardware and re-torque at intervals for the first 10, 100, and 1000 miles.

**NOTE: 4 wheel alignment is required immediately following the installation.**

<b>Kit Contents</b>		
<b>P/N</b>	<b>Item Description</b>	<b>Qty</b>
26022-200	Belltech Lift Strut	1
4926-001	Bump Stop	1
65210031	Vent Disk	1
4935-001	15mm Packer	1
4936-001	25mm Packer	1
25003-016	16mm Ring	2
25003-010	10mm Ring	4
25003-002	Belltech Spring Perch	1