



bajadesigns
The Scientists of Lighting

44-8053 S2 Pro Fog Pocket Kit Fits 21-On Ford, Raptor



2950 Norman Strasse Rd • San Marcos • CA • 92069

Phone 760-560-2252 • Fax 760-560-0383

info@bajadesigns.com • www.bajadesigns.com



baja designs[®]
The Scientists of Lighting

LIMITED LIFETIME WARRANTY

Baja Designs proudly offers a LIFETIME WARRANTY against manufacturer's defect on all the products that we manufacture.

These are comprehensive warranties; other than the exclusions below – you're covered. If your LED or HID bulb burns out, you're covered. Additionally, cutting off our connector or changing your lenses does not automatically void your warranty.

Exclusions:

Installation errors, abuse, misuse or crash damage. You must be the original owner of the product and can supply proof of purchase.

Baja Designs manufactures its own products as well as resells products manufactured by others. Baja Designs makes no express or implied warranties on products not manufactured by Baja Designs including without limitation any warranties or merchantability and fitness for a purpose. We will, however, pass on all warranties made by the manufacturer, who has sole responsibility for performing such warranties.

Baja Designs will pay the freight if your product is less than 90 days old, otherwise defective products must be returned to Baja Designs, Inc., freight prepaid. At our option, we will repair or replace items in question and return them at no charge. If the identical product is no longer available, we will replace with a similar product of equal value. Baja Designs Inc. will not be responsible for any indirect or consequential damages in connection with defective merchandise.

Items purchased through a Baja Designs authorized dealer must be returned through the dealer. Only available on LED auxiliary lights and product must be in sellable condition at MSRP. Product that has been damaged in any way after the original purchase date will be excluded from this guarantee.

Indemnification:

Buyer hereby acknowledges off-roading, racing and driving at night are dangerous activities and that the products and/or supplies purchased from Baja Designs are used in an inherently dangerous activity that may endanger life and limb; and in no event shall the seller, or seller's heirs and assigns, be held liable for consequential damages, nor shall seller's liability on any claim for damages arising out of or connected with the sale, delivery, or use of purchased products and/or supplies exceed the purchase price of the products and/or supplies.

Buyer is responsible for ensuring that it uses the products (and its vehicle) in accordance with all applicable laws, regulations, guidelines, and standards of care. Buyer acknowledges that some products may only be used when off-roading, and Buyer will comply with all vehicle and road safety guidelines. Buyer is solely responsible for (and will indemnify and hold Bestop harmless for) any claims, losses, damages, fines, fees, costs, or other amounts arising out of Buyer's non-compliance with these provisions.

Tools Required

- * 4mm, 5mm Hex Key
- * 8mm, 10mm, 7/16", 9/16", T-10 Torx, T-40 Torx socket
- * 7/16", 9/16" wrench

1. Using a 10mm socket, remove the 4x bolts securing the fog light splash guard (↖). Use a 8mm socket to remove the 1x fasteners securing the bumper support (↖). Loosen the bumper support bolt on the other side and place the support to the side.

2. Using a t-40 torx bit, remove the 2x bolts securing the top of the fog light bracket. Unplug the 2 lights from the OEM wiring by pulling back on the red tab and pushing down on the release tab.

3. Using a t-10 torx bit, remove the 6x bolts (per light) securing the light.

4. Attach the supplied brackets to the light. Each light will have two brackets. The longer bracket will be bolted to the outside. A passenger side light is shown for example. Make sure to use the supplied serrated washers in between the bracket and light to eliminate any rotation from vibration.

3. Before torquing down the light, angle the bracket roughly 2° to the face of the light. Lightly tighten the bracket & place the light into the OEM fog light bracket. Check to ensure the light is centered. Once all are verified, finish torquing down the bracket onto the lights.

4. Place all the lights into the OEM fog light bracket. Use the 4x OEM fasteners removed in step 4. to secure the light.

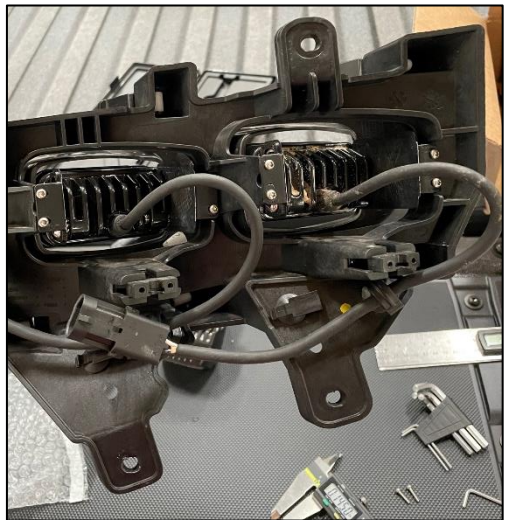
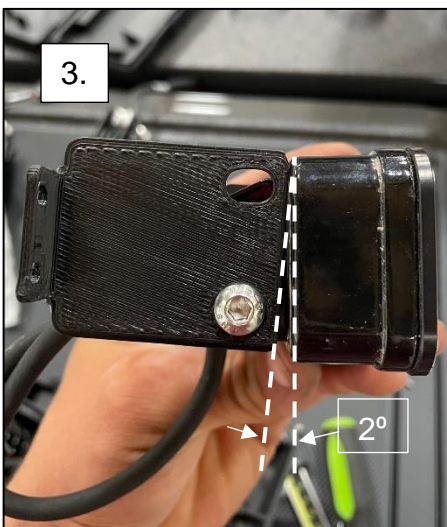
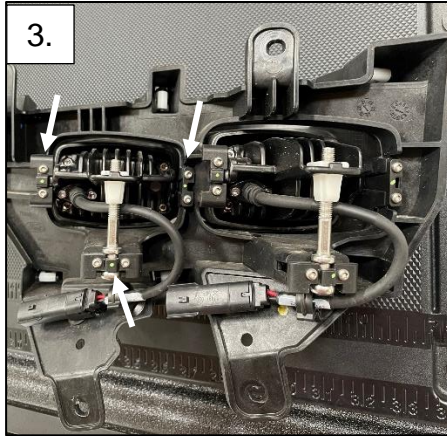
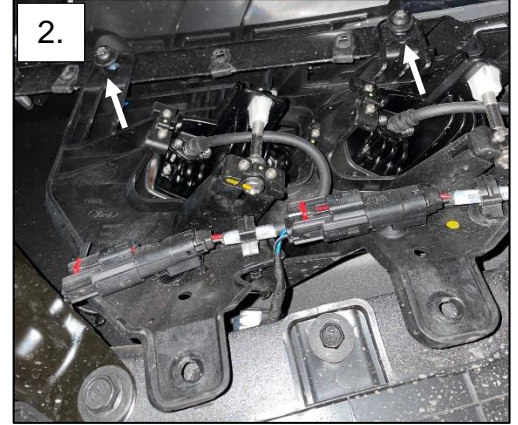
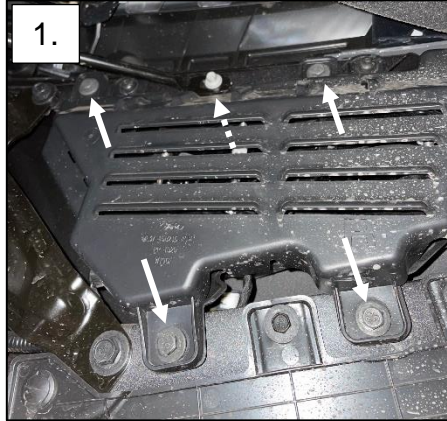

5. Using the supplied wire harness adapter, connect the adapter to the light and OEM wiring. The same functions will power the lights...

OEM Fog Light Switch → Outer Lights
 Aux Switch 1 → Center Lights

One thing to note, the high beams will shut off the fog lights. To get around this, an additional small splitter harness and anti back feed harness will need to be purchased and installed as shown. (61-3607 Splitter Harness, 60-0017 Anti-Backfeed Harness)

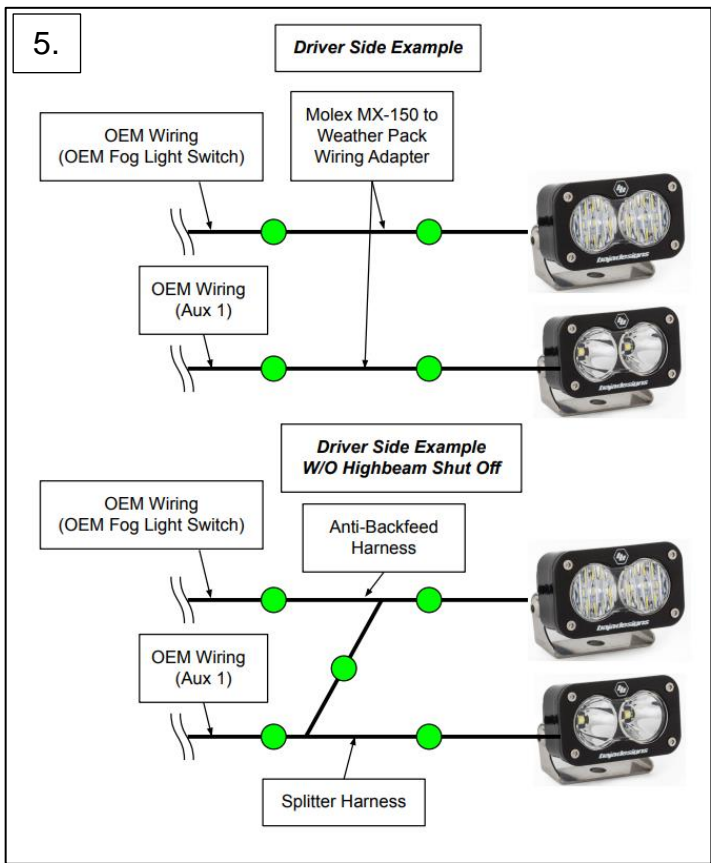

*Tie all wires away from sharp, hot, and/or rotating components.

* Re-torque all the fasteners after 100 miles.

*Your install is now complete! Thank you for choosing Baja Designs.

	<i>Lighting Specs</i>		
	Lumens	Wattage	Amps
S2 Sport	2,260	24	1.8
S2 Pro	4,900	48	3.4

