

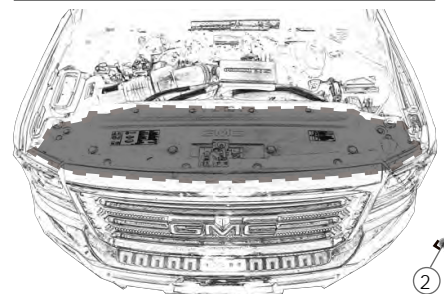

BEHIND THE GRILLE INSTALLATION

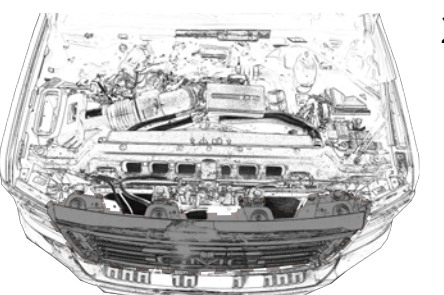

FRONT OF TRUCK



FRONT OF TRUCK

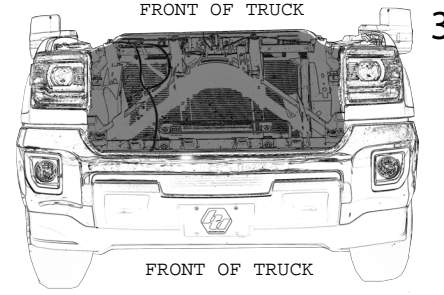

FRONT OF TRUCK

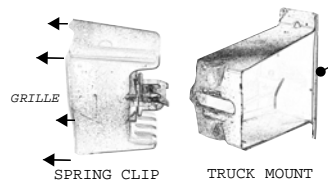

GRILLE
SPRING CLIP
TRUCK MOUNT

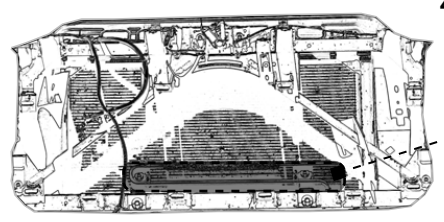

PASSENGER SIDE DRIVER SIDE

1. Put vehicle in Park. Disconnect battery. Remove 12 plastic clips shaded in the image (to the left). Insert a flatblade screwdriver, or clip removal tool at this location and gently pry upward. Lift up and remove the plastic shroud.

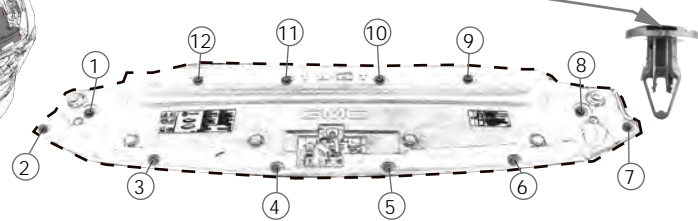

2. Use a 10mm socket and ratchet, remove 4 screws holding the grille in place.

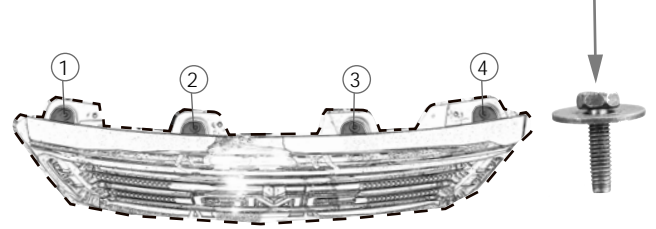

3. Apply constant force, outward, on the grille in the 10 shaded regions shown below to release the spring clips. Start from one side and work across the vehicle.

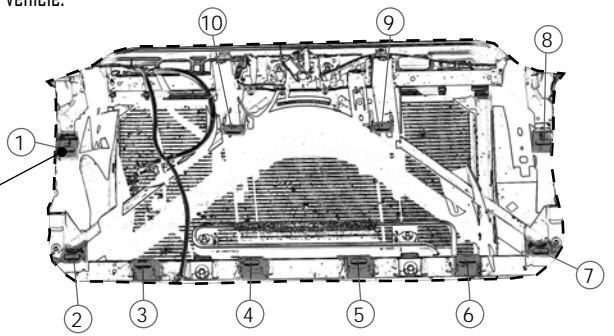

4. Locate the oil cooler fins in the shaded region. Gently push down on the fins until the cross-section below is achieved. This will make room for the lightbar.

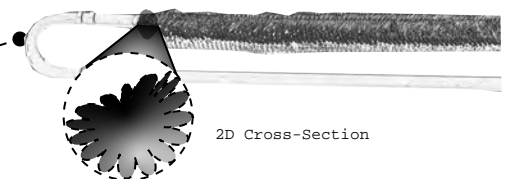

2D Cross-Section

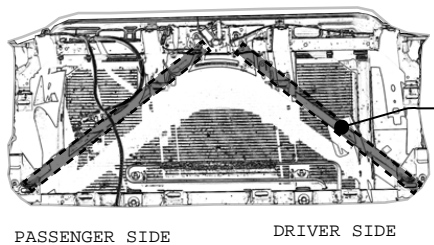
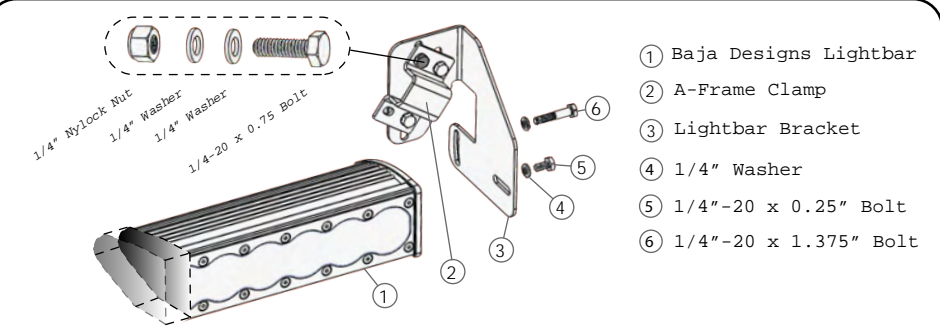

PASSENGER SIDE DRIVER SIDE

5. Place item 3 (Lightbar Bracket) on the Driver Side A-frame in the area shaded.

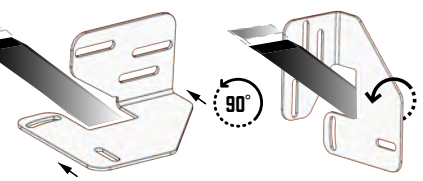

Assemble as shown above with a 7/16" ratchet and wrench. Add anti-seize to bolts for best results. The S8 does not have item 6.

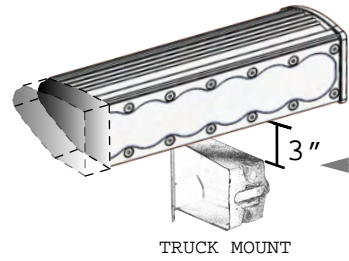

TRUCK MOUNT

The bottom of the lightbar should sit around 3" above the truck mount for the OnX6 and sit slightly above 2 3/8" for S8. Refer to points 3 & 6 in Step 3.

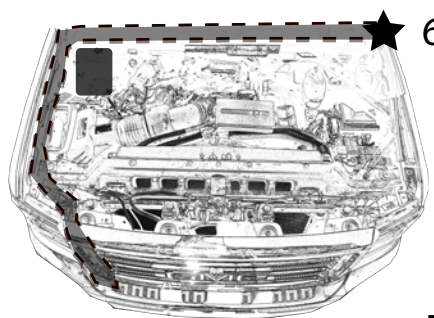

FRONT OF TRUCK

6. Route the wiring harness in the dashed region to the left. Remove the battery cover located in the shaded rectangle to the left. With a 10mm, deep socket and ratchet, undo a positive and negative terminal. Attach the proper colored leads, red (positive) & black (negative), to the terminals. Secure with the 10mm ratchet or wrench. Remove connectors from the switches on the harness.

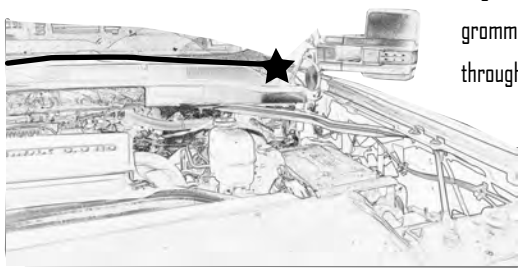

7. Route the harness to the star in the image to the bottom left. Open the Driver Side door, to reveal an opening to the engine bay where the fender and body meet, and a rubber grommet right below the top door hinge. Route wires through the engine bay opening.

Push the grommet out from the interior of the Driver Side, under the dash, and cut an "X" into it to feed wires through. Re-attach connectors to switches. Thank you for choosing Baja Designs.



bajadesigns®

THE SCIENTISTS OF LIGHTING

LIMITED LIFETIME WARRANTY

Baja Designs proudly offers a LIFETIME WARRANTY against manufacturer's defect on all of the products that we manufacture.

These are comprehensive warranties; other than the exclusions below - you're covered. If your LED or HID bulb burns out, you're covered. Additionally, cutting off our connector or changing your lenses does not automatically void your warranty.

Exclusions:

Installation errors, abuse, misuse or crash damage. You must be the original owner of the product and can supply proof of purchase.

Baja Designs manufactures its own products as well as resells products manufactured by others. Baja Designs makes no express or implied warranties on products not manufactured by Baja Designs including without limitation any warranties or merchantability and fitness for a particular purpose. We will however, pass on all warranties made by the manufacturer, who has sole responsibility for performing such warranties.

Baja Designs will pay the freight if your product is less than 90 days old, otherwise defective products must be returned to Baja Designs, Inc., freight prepaid. At our option, we will repair or replace items in question and return them at no charge. If the identical product is no longer available, we will replace with a similar product of equal value. Baja Designs Inc. will not be responsible for any indirect or consequential damages in connection with defective merchandise.

Items purchased through a Baja Designs authorized dealer must be returned through the dealer. Only available on LED auxiliary lights and product must be in sellable condition at MSRP. Product that has been damaged in any way after the original purchase date will be excluded from this guarantee

Indemnification:

Buyer hereby acknowledges off-roading, racing and driving at night are dangerous activities and that the products and/or supplies purchased from Baja Designs are used in an inherently dangerous activity that may endanger life and limb; and in no event shall the seller, or seller's heirs and assigns, be held liable for consequential damages, nor shall seller's liability on any claim for damages arising out of or connected with the sale, delivery, or use of purchased products and/or supplies exceed the purchase price of the products and/or supplies.