



350 S. St. Charles St. Jasper, In. 47546
Ph. 812.482.2932 Fax 812.634.6632

www.ridetech.com

Part # 11320298
78-88 GM "G" Body Air Suspension System

Front Components:

1	11323001	HQ Series Front Shockwaves for Strong Arms
1	11329599	Front Tru-Turn Suspension Package
1	11329120	Front MuscleBar

Rear Components:

1	11325401	HQ Series Rear Shockwaves
1	11227299	Axle R-Joint Kit & Installation Tool
1	11324499	Rear Lower Strong Arms
1	11329122	Rear MuscleBar



Part # 11323001 - 78-88 GM G-Body Front HQ Series Shockwave

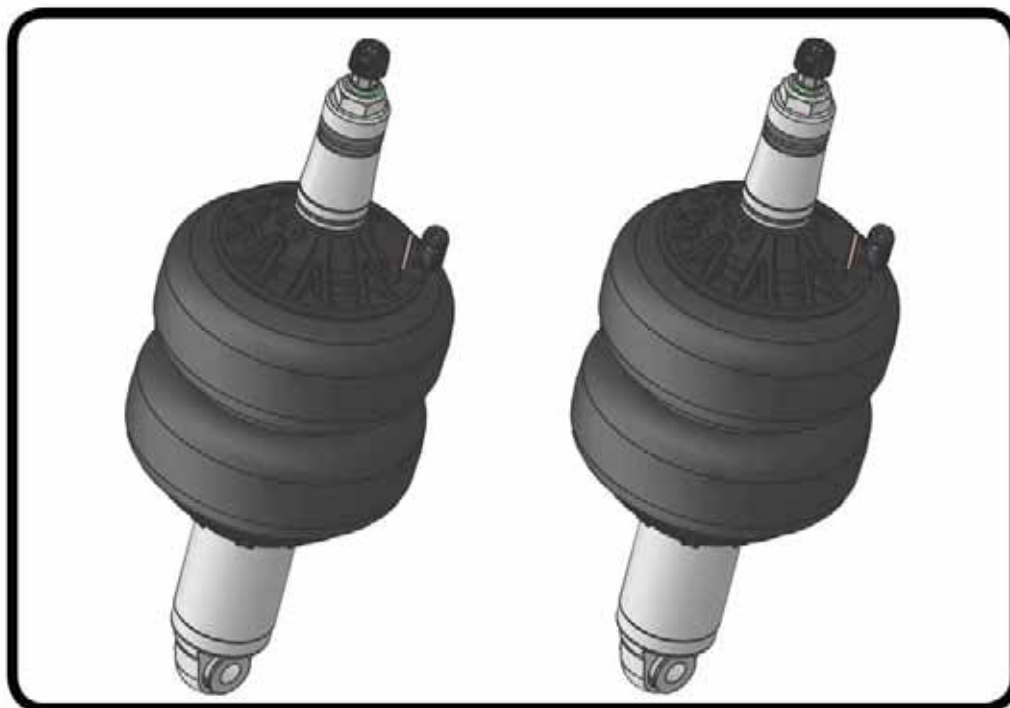

Recommended Tools



1000 Series Bellow, 2.00" Stud/Eye 3.6" Shock Installation Instructions

Table of contents

Page 2..... Included components

Page 3..... Notes and Care of Your Shockwave

Page 4..... Shock Adjustment

ShockWave Dimensions:

Center of bearing to Center of bearing:

Compressed: 10.30"

Ride Height: 12.13"

Extended: 13.32"

THE DELRIN BALL REQUIRES A 3/4" HOLE FOR THE FLANGE TO GO THROUGH. THIS CAN BE DRILLED WITH A UNIBIT.

www.ridetech.com
812-482-2932





Major ComponentsIn the box

Item #	Part #	Description	QTY
1	982-10-803	3.6" Stroke HQ Series Shock	2
2	90009988	2.00" Stud Top (Installed on Shock) - Includes Adjuster Knob & Screw	2
3	24090199	1000 Series 6.5" Double Convoluted AirSpring	2
4	803-00-199	AirSpring Locking Ring (Installed on shock)	2
5	99055000	Locking Ring Set Screw (Installed on shock)	2
6	90002062	Spacers - INCLUDED WITH STRONGARMS	4
7	90002312	2.00" Aluminum Stud Top Base	2
8	90001904	Bottom Delrin Ball	2
9	90001903	Top Delrin Ball	2
10	90001902	Delrin Ball Aluminum Top Cap	2
11	99562003	9/16"-18 Thin Nylok Nut	2
12	210-35-120-0	Adjuster Knob - (90009988 assembly)	2
13	90009969	#4-40 X 1/4" SS, 18-8 Pan Head Torx Cap - (90009988 assembly)	2
	70012160	2.00" Stud Top Metering Rod (installed in stud top)	2
	90001994	5/8" ID Bearing (installed in shock and eyelet)	4
	90001995	Bearing Snap Ring (installed in shock and eyelet)	8

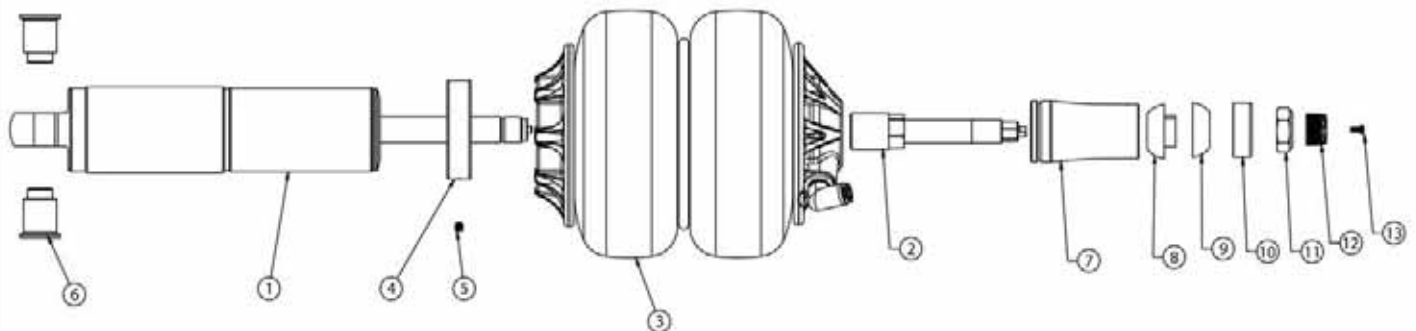

THE DELRIN BALL REQUIRES A 3/4" HOLE FOR THE FLANGE TO GO THROUGH. THIS CAN BE DRILLED WITH A UNIBIT.

WARNING: ATTEMPTING TO REMOVE THE AIR FITTING WILL DAMAGE IT AND VOID THE WARRANTY.



ShockWave Installation



1. Drill the OEM shock hole out to 3/4". This can be done with a Unibit. The Shockwave top can come in contact with the coil spring retaining fingers. Test fit the ShockWave to determine if they need cut off. A die grinder works well here.



2. For air spring clearance some trimming must be done on the outer portion of the coil spring pocket. The amount of trimming necessary will vary from one car to another, it is best to install the Shockwave onto the lower arm and inflate the bellows. Check clearance throughout full suspension travel. **(Inflated diameter of this Shockwave is approximately 6.5")** This is best done with a cut off wheel or plasma cutter. Make the cuts round, square corners will create a fracture point.



3. To allow clearance for the Shockwave, some trimming may need to be done on the inside of the coil spring pocket as shown by the white line in the picture. This is best done with either a cut off wheel or plasma cutter. Grind all cuts smooth when finished.

Note: It may be helpful to go ahead and install the lower StrongArms and Shockwaves to determine exactly what needs to be removed.



ShockWave Installation

4.

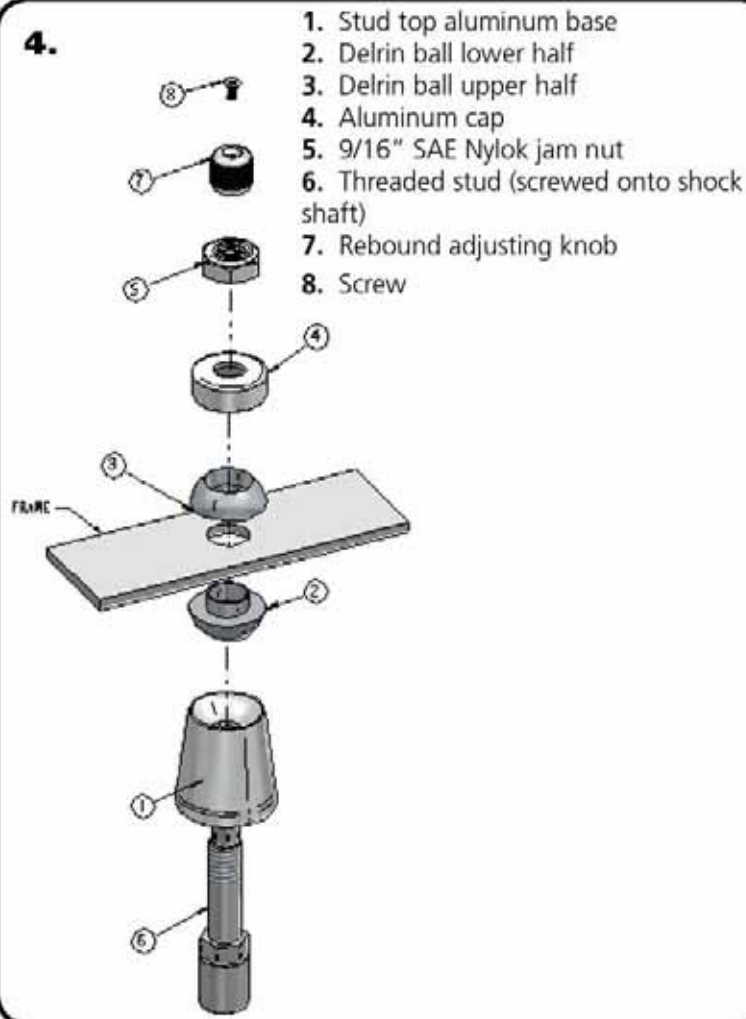

1. Stud top aluminum base
2. Delrin ball lower half
3. Delrin ball upper half
4. Aluminum cap
5. 9/16" SAE Nylok jam nut
6. Threaded stud (screwed onto shock shaft)
7. Rebound adjusting knob
8. Screw

Note: The airline must also be routed at this time. It can be ran through the subframe toward the rear of the vehicle.

4. The air fitting location can be rotated by twisting the bellow assembly separate of the shock. Place the Shockwave into the coil spring pocket with the stud sticking through the OEM shock hole. See assembly **Diagram 4**. OEM Shock hole **must** be drilled out to $\frac{3}{4}$ "

1. Stud top aluminum base
2. Delrin ball lower half
3. Delrin ball upper half
4. Aluminum cap
5. 9/16" SAE Nylok jam nut
6. Threaded stud (screwed onto shock shaft)
7. Rebound adjusting knob
8. Screw

5.

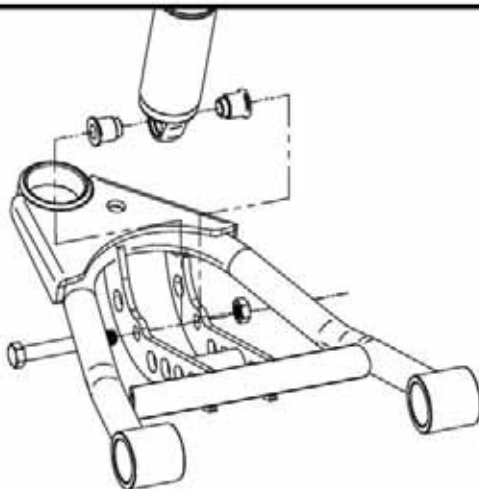

5. Raise the lower arm up to the Shockwave and bolt them together using the $\frac{1}{2}$ " x $3\frac{1}{4}$ " bolt and Nylok supplied w/ the lower arms. An aluminum spacer will be on each side of the bearing. Torque to 75 ftbs.

6. Raise the lower control arm to full compression and double-check to make sure the Shockwave does not rub on anything at any-time. Allowing the Shockwave to rub on anything will cause failure and is not a warrantable situation.

7. The best ride quality will occur around 50-60% suspension travel; depending on vehicle weight this typically occurs around 85-100 psi.



Notes and Care of your Shockwaves

NOTES:

WARNING: ATTEMPTING TO REMOVE THE AIR FITTING WILL DAMAGE IT AND VOID THE WARRANTY.

TIGHTENING THE TOP 9/16"-18 NUT: SNUG THE NUT DOWN AGAINST THE TOP CAP. YOU NEED TO BE ABLE TO ARTICULATE THE SHOCK BY HAND.

You can clock the airfitting location on the ShockWave by turning the AirSpring assembly of the shock. Make sure the fitting doesn't contact the frame.

When cutting the airline, use a razor blade. The cut needs to be a clean cut and square for the airline to seal properly.

The Locking ring on the shock is **NOT** adjustable. These rings are set at the factory to optimize the AirSpring stroke with the shock stroke.

The care and feeding of your new ShockWaves

1. Although the ShockWave has an internal bumpstop, **DO NOT DRIVE THE VEHICLE DEFLATED RESTING ON THIS BUMPSTOP. DAMAGE WILL RESULT.** The internal bumpstop will be damaged, the shock bushings will be damaged, and the vehicle shock mounting points may be damaged to the point of failure. This is a non warrantable situation.
2. Do not drive the vehicle overinflated or "topped out". Over a period of time the shock valving will be damaged, possibly to the point of failure. This is a non warrantable situation! If you need to raise your vehicle higher than the ShockWave allows, you will need a longer unit.
3. The ShockWave is designed to give a great ride quality and to raise and lower the vehicle. **IT IS NOT MADE TO HOP OR JUMP!** If you want to hop or jump, hydraulics are a better choice. This abuse will result in bent piston rods, broken shock mounts, and destroyed bushings. This is a non warrantable situation.
4. Do not let the ShockWave bellows rub on anything. Failure will result. This is a non warrantable situation.
5. The ShockWave product has been field tested on numerous vehicles as well as subjected to many different stress tests to ensure that there are no leakage or durability problems. Failures have been nearly nonexistent unless abused as described above. If the Shockwave units are installed properly and are not abused, they will last many, many years. ShockWave units that are returned with broken mounts, bent piston rods, destroyed bumpstops or bushings, or abrasions on the bellows will not be warrantied.

ridetech



350 S. St. Charles St. Jasper, In. 47546
Ph. 812.482.2932 Fax 812.634.6632

www.ridetech.com



Part # 11329599 – G Body /11399599 – S10 78-88 GM “G” Body/82-03 S10 Tru-Turn Suspension Package

Front Components:

1	11323695	Upper Strong Arms
1	11322895	Lower Strong Arms
1	11329595/11399595	Tru Turn System

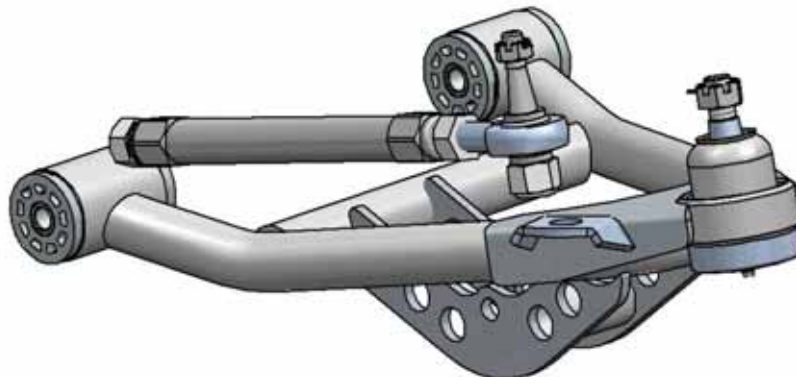
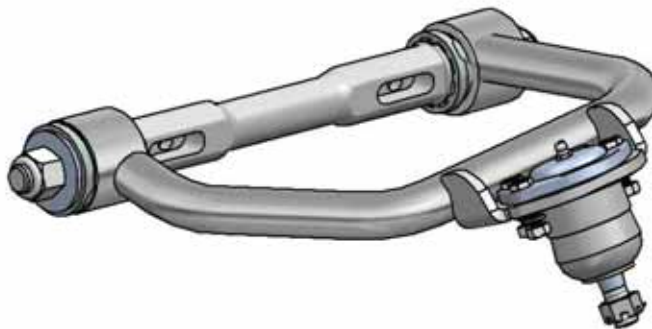



350 S. St. Charles St. Jasper, In. 47546
Ph. 812.482.2932 Fax 812.634.6632

www.ridetech.com

Part # 11323695
78-88 GM "G" Body/82-03 S10 Upper StrongArms

Components:

1	90002379	Drivers side arm
1	90002380	Passenger side arm
2	90000913	Upper ball joint – Proforged # 101-10020
2	90003375	Caster Adjustable Cross shaft
2	70010826	Delrin Bushing – no ledge
2	70010827	Delrin Bushing – small ledge
4	70010759	Delrin Bushing – outer
4	90002737	Cross shaft T-washer
4	70011955	Zero Offset Caster Slugs
2	99753007	¾" x 1 ¾" Flat Washer
2	99753005	¾" SAE Flat Washer
4	99622005	5/8"-18 Lock Nut

Hardware:

4	99433004	7/16" USS Flatwasher	Cross shaft to Frame
4	99431009	7/16"-14 x 2 ½" Bolt	Cross shaft to Frame
4	99432001	7/16"-14 Nylok Nut	Cross shaft to Frame

DUE TO THE SHANK OF THE BALL JOINT BEING LONGER, THE BALL JOINT BOOT IS DESIGNED TO SEAL ON THE BALL JOINT SHANK. IT DOES NOT SEAL AGAINST THE SPINDLE.

STRONGARMS



1. Fasten the upper arm to the frame using the supplied 7/16" hardware. Reinstall the current alignment shims, but **vehicle must be realigned**. Torque to 55 ft-lbs.

2. Drop ball joint down through upper arm. Slide ball joint boot over stud, then place boot retainer over the boot.

Torque Specs:

Upper Ball joint - 61 ftlbs and tighten to line up cotter pin.

3. Fasten the ball joint to the spindle w/ the new castle nut and cotter pin supplied.

4. Tighten the cross shaft nuts enough to create drag on the delrin bushings, the arm should still move.

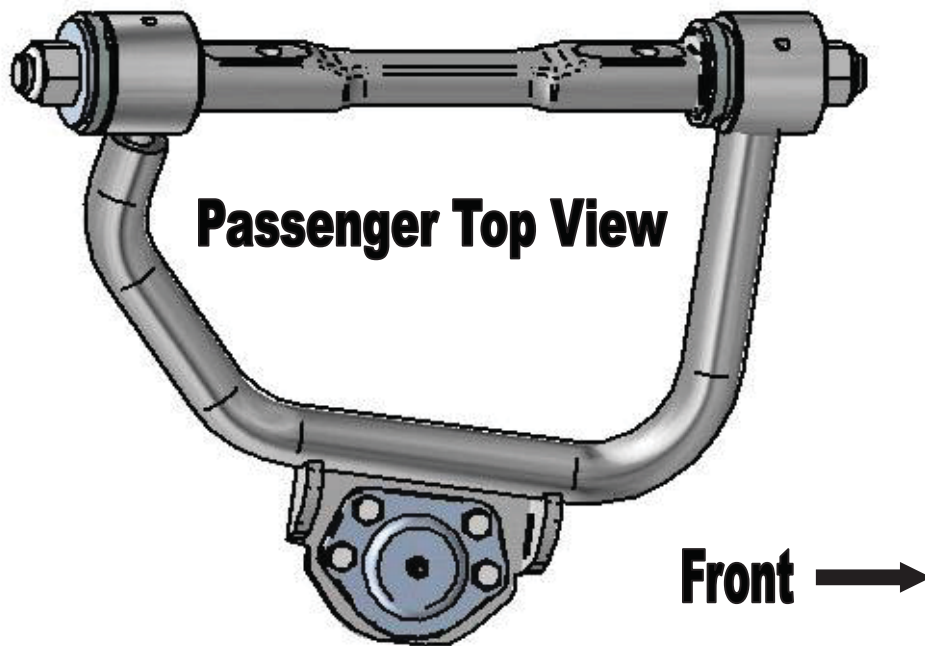

STRONGARMS

Driver Side – Top View

Item #	Part #	Description	Qty.
1a.	90002379	Driver Upper Control Arm - SHOWN	1
1b.	90002380	Passenger Upper Control Arm - SHOWN	1
2	90000913	Upper Ball Joint	2
3.	70010759	Delrin Bushing – 2" OD Ledge	4
4.	70010826	Delrin Bushing – no ledge	2
5.	70010827	Delrin Busing – 1/5" PD Ledge	2
6.	90003375	Caster Adjustable Cross shaft	2
7.	70011955	Caster Slug	4
8.	90002737	T-Washer	4
9.	99622005	5/8 – 18 Toplock Jam Nut	4
10.	99753007	3/4" x 1 3/4" Flat Washer	2
11.	99753005	3/4" SAE Flat Washer	2

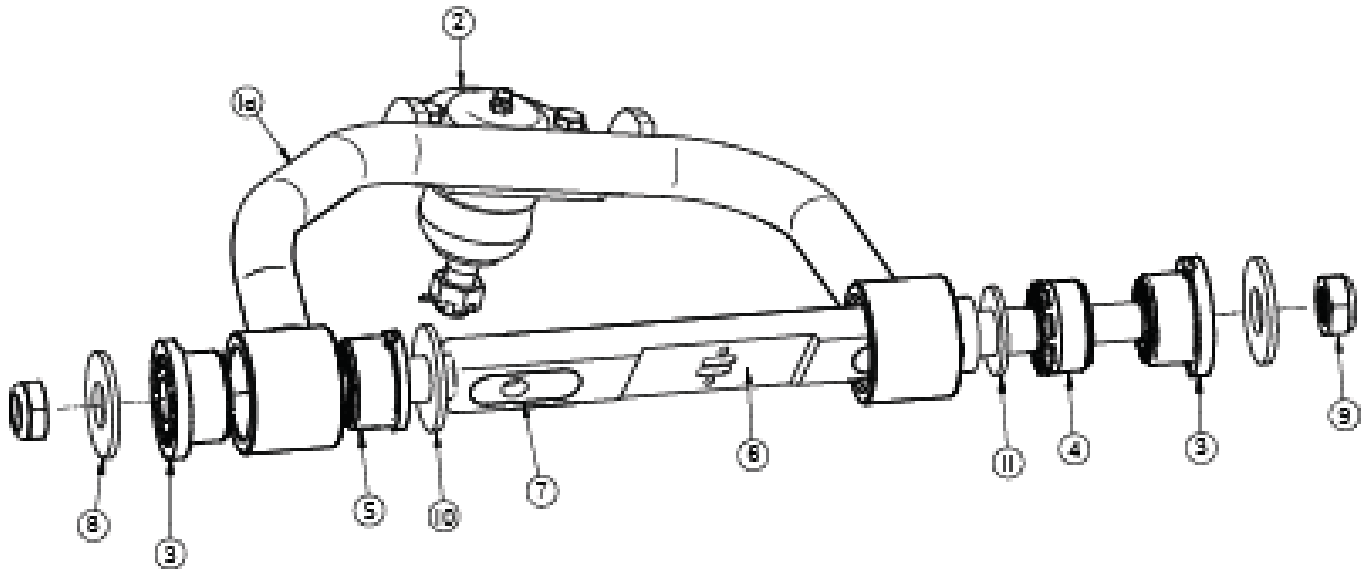

STRONGARMS

FRONT
→

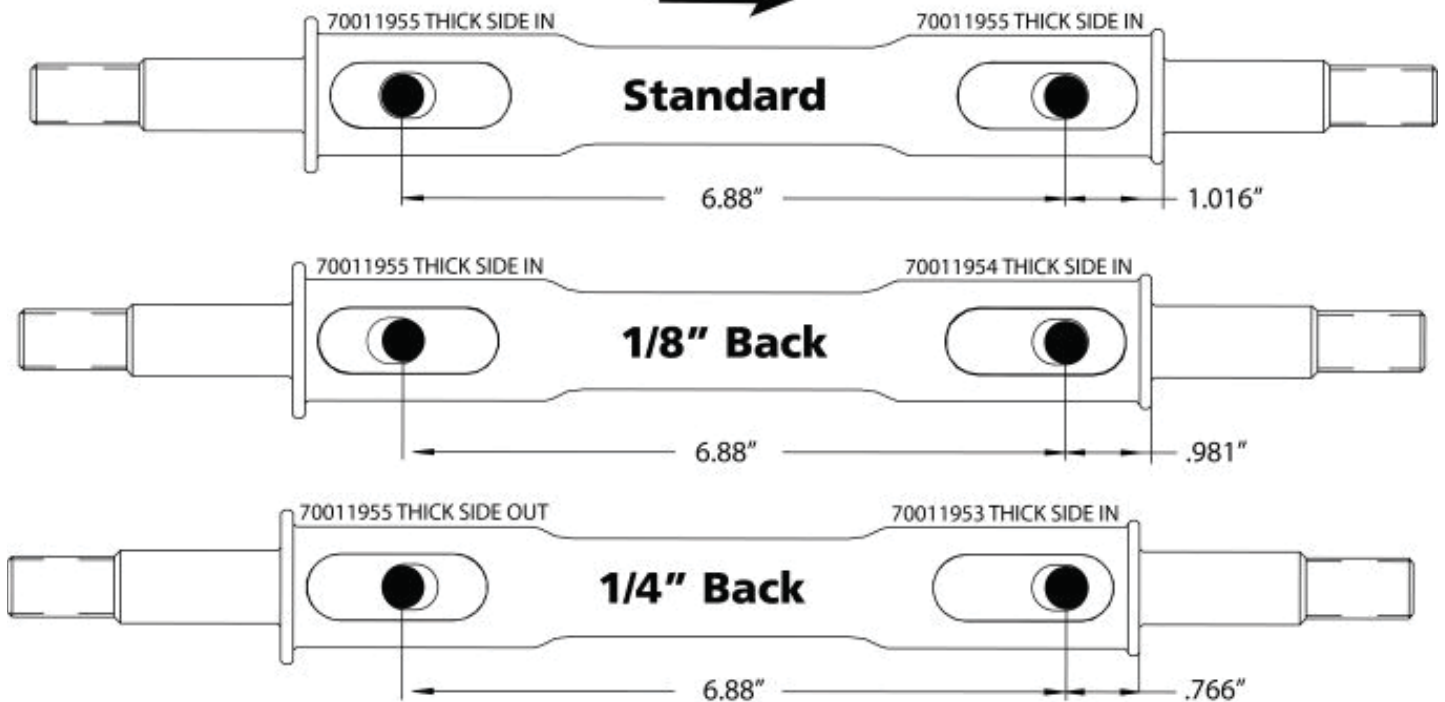

These StrongArms come equipped with a changeable caster slug setup. This allows you to add or remove caster from the front suspension, if desired. The caster slugs that come supplied in the kit are setup to be centered. The caster slugs allow you to add or remove caster without having to use a stack of shims. If more or less caster is desired, optional slugs can be purchased from Ridetech or your Ridetech dealer. The diagram above will help you determine what caster slug you may need if trying to achieve more caster. It will also show you how to position the caster slug.

STANDARD CAATER SKUGS INCLUDED IN KIT = 4 OF 70011955

CASTER SLUGS REQUIRED TO GET MORE CASTER

1/8" BACK = REQUIRES 2 OF 70011954

1/4" BACK = REQUIRES 2 OF 70011953

Caster Explained:

To understand caster you need to picture an imaginary line that runs through the upper ball joint and extends through the lower ball joint. From the side view the imaginary line will tilt forward or backward. The tilting of this imaginary line is defined as caster.

Caster is measured in degrees by using a caster camber gauge. If the imaginary line described above tilts towards the back of the car, at the top, then you will have positive caster. If the imaginary line tilts forward then you would have negative caster.

Positive caster provides the directional stability in your car. Too much positive caster will make the steering effort difficult. Power steering will allow you to run more positive caster. Negative caster requires less steering effort but can cause the car to wander down the highway.

STRONGARMS

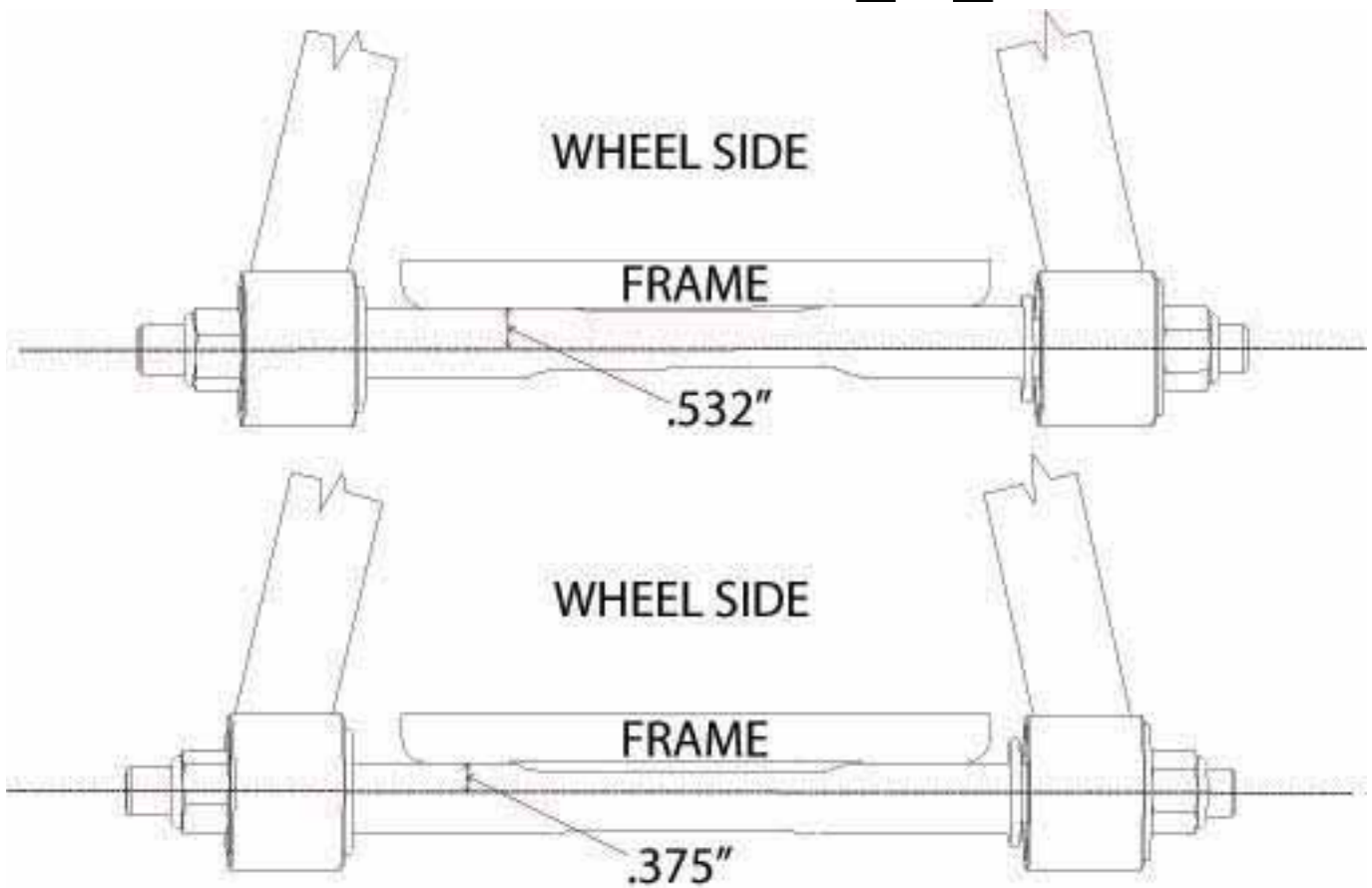

Offset Upper Cross Shaft

The cross shaft that is used in the upper control arm is offset. The offset combined with the caster slug option allows you to achieve the alignment setting you desire with minimal shims. To change the direction that the Icon faces, simply spin the cross shaft in the control arm.

If you are after an aggressive **Track or Autocross Alignment**, bolt the control arm to the frame bracket with the arm offset to the inside of the car (like the top illustration). The Ridetech Icon will be facing the engine.

If a **Street Alignment** is desired, bolt the control to the frame bracket with the arm offset to the outside of the car (like the bottom illustration). The Ridetech Icon will be facing the wheel.



350 S. St. Charles St. Jasper, In. 47546
Ph. 812.482.2932 Fax 812.634.6632

www.ridetech.com

Part # 11322895
78-88 GM "G" Body/82-03 S10 Lower StrongArms
For Use w/ Shockwaves or CoilOvers

Components:

1	90002377	Driver side lower arm
1	90002378	Passenger side lower arm
2	90000896	Ball joint – Proforged # 101-10049
2	90000572	Inner bushing sleeve -12mm x 2.375" - <i>installed in control arm</i>
2	90000573	Inner bushing sleeve -12 mm x 3.00"
2	90001094	Inner bushing sleeve – 14mm x 3.00" - <i>installed in control arm</i>
8	70010759	Delrin bushing half
4	90002062	Aluminum spacer – Shock to lower arm

Hardware: The hardware kit includes hardware for both the G-Body and the S10, be sure to use the correct hardware for your application.

2	99501005	½"-13 x 3 1/2" Gr.8 bolt	Shockwave to lower arm - BOTH
2	99502009	½"-13 Nylok nut	Shockwave to lower arm - BOTH
4	99503014	½" SAE Flat Washer	Shockwave to lower arm - BOTH
2	99121001	M12-1.75 X 90mm Bolt	StrongArm to Frame - BOTH
2	99121002	M12-1.75 X 110mm Bolt	StrongArm to Frame – G-BODY
4	99122001	M12-1.75 Nylok nut	StrongArm to Frame – (4) G-BODY/ (2)2 S10
4	99123002	M12 Flat Washer	StrongArm to Frame – (4) G-BODY/ (2)2 S10
2	99141003	M14-2.0 x 100mm Hex Bolt	StrongArm to Frame – S10
2	99142002	M14-2.0 Nylok Nut	StrongArm to Frame – S10
2	99143001	M14 Flat Washer	StrongArm to Frame – S10

STRONGARMS

Installation Instructions



1. After removing the factory lower control arm, clean the bushing mounting surfaces on the frame to make sure they are fairly smooth.

NOTE: IF YOU ARE INSTALLING THESE CONTROLS ARMS ON A G-BODY, THE 3" LONG SLEEVE IN THE CONTROL ARM WILL NEED TO BE CHANGED TO THE 3" SLEEVE THAT IS INCLUDED SEPERATELY IN THE KIT.

2. Fasten the lower arm to the frame using the correct hardware that is supplied in the kit. G-Body uses (2) 12 mm bolts. S10 uses a 12mm and 14mm bolt to attach the control arm. Torque to 75 ft-lbs.

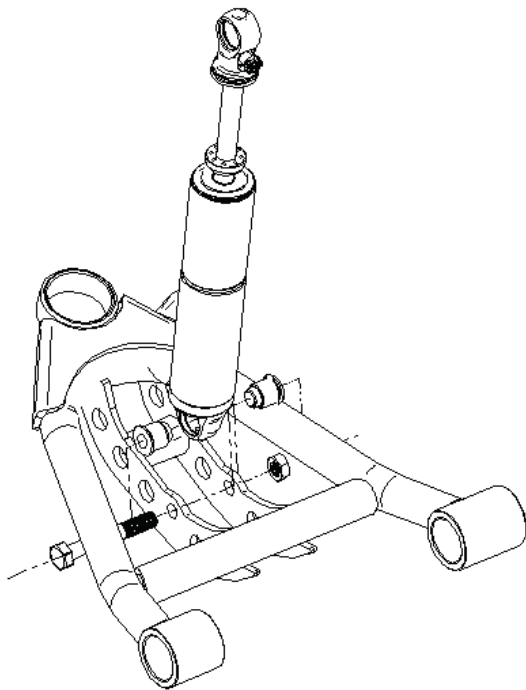

3. Swing the lower StrongArm up to the shock and secure with the $\frac{1}{2}$ " x 3 $\frac{1}{2}$ " bolt, flat washers, and Nylok nut. An aluminum spacer must be installed in each side of the bearing. The small diameter of the spacer will get inserted into the shock bearing. Torque to 75 ft-lbs.

4. Slide the ball joint boot over the stud, then push the stud up through the spindle.

Torque Specs:

Lower Ball joint - 79 ftlbs and tighten to line up cotter pin

5. Grease the ball joints.

STRONGARMS

Item #	Part #	Description	Qty.
1.	90002377	Driver side arm – SHOWN	1
	90002378	Passenger side arm	1
2.	9000896	Ball Joint	2
3.	90000572	Inner bushing sleeve – narrow	2
4.	90002672	Inner bushing sleeve – wide	2
5.	70010759	Delrin bushing half	2
6.	70010759	Delrin bushing half	2
7.	90002062	Aluminum bearing spacer	4
8.	99501005	1/2"-13 x 3 1/2" bolt	2
9.	99502009	1/2"-13 Nylok nut	2
	99503014	1/2" SAE Flat Washer not shown	4

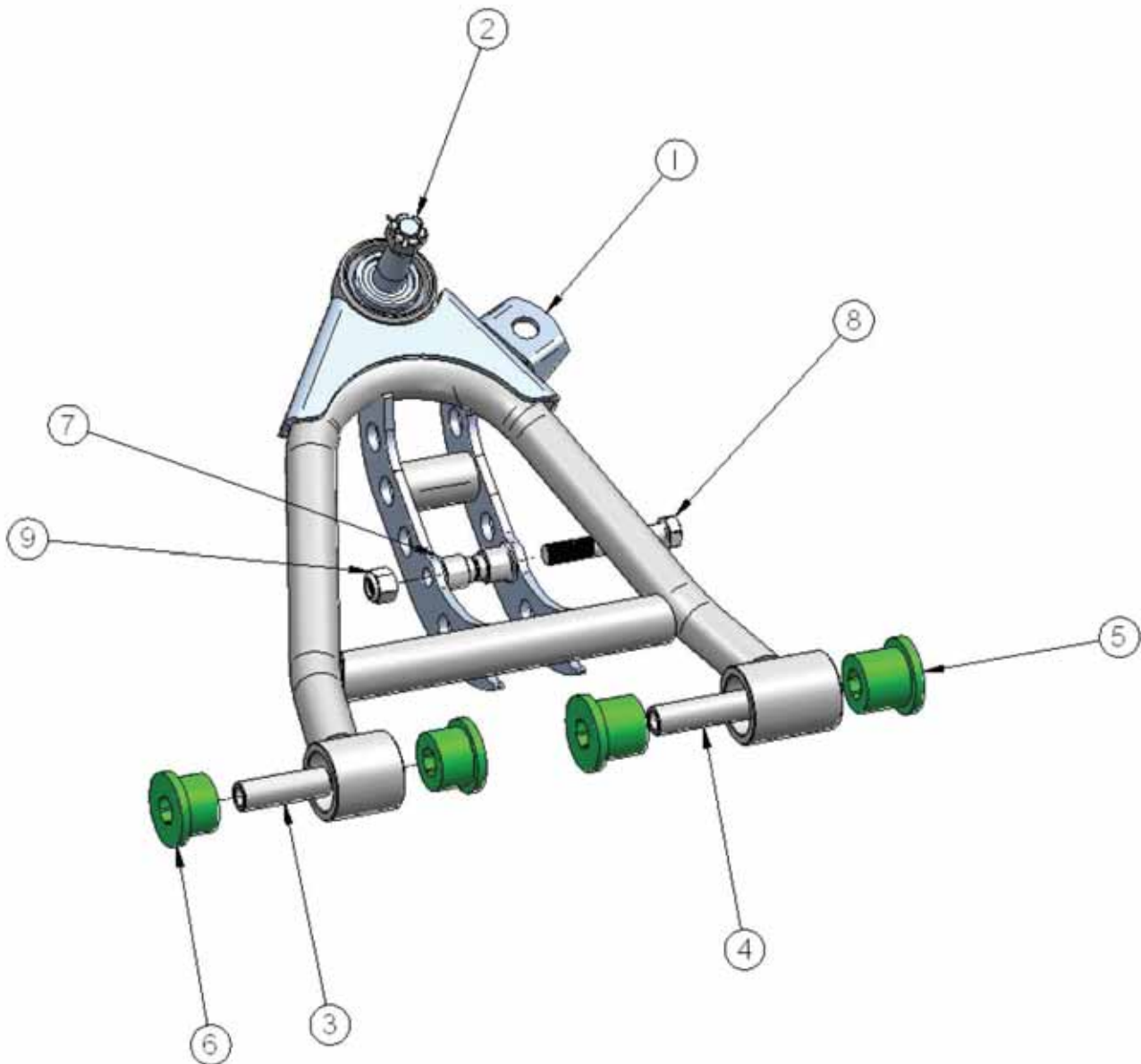



350 S. St. Charles St. Jasper, In. 47546
 Ph. 812.482.2932 Fax 812.634.6632
www.ridetech.com

Part # 11329595/11399595
78-88 G-Body/82-03 S10 TruTurn System without Spindles



Item #	Part #	Description-Specification	Qty.
1.	90001590	Heim end	2
2.	99800002	5/8"-18 RH jam nut	2
3.	90002676	Heim End Spacer	6
4.	99622003	5/8"-18 Lock Nut-35 ft lbs	2
5.	90002374	Tie Rod Stud	2
6.	99432005	7/16"-20 castle nut-35 ft lbs	2
7.	90002375	Adjusting sleeve	2
8.	99952002	3/32" cotter pin	2
9.	99800003	5/8"-18 LH jam nut	2
	90003058	Inner Tie Rod -S10 ONLY(not shown)	2

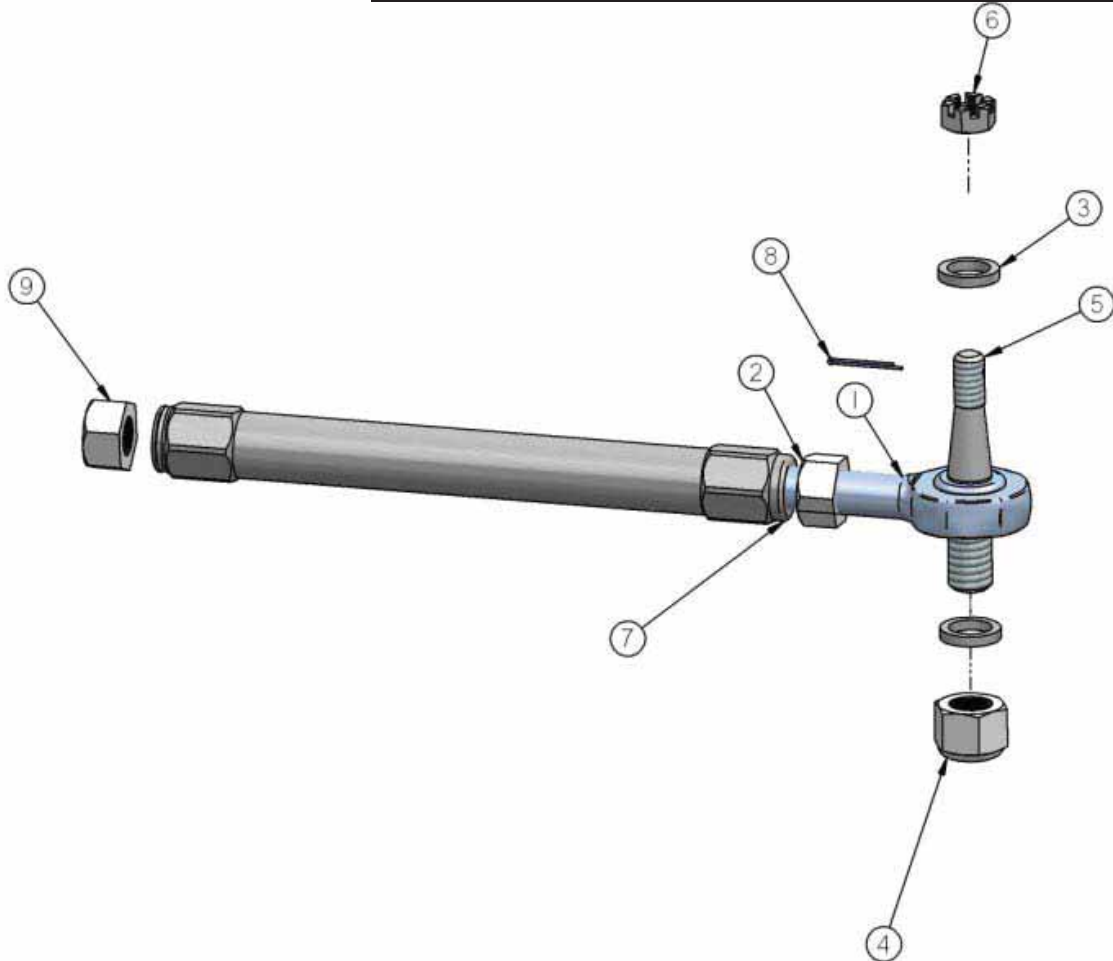



350 S. St. Charles Street Jasper, In. 47546 www.ridetech.com

Installation instructions:

IF INSTALLING A S10 KIT, IT WILL COME WITH NEW INNER TIE RODS!

NOTE: The number in (#) is the number of the part in the drawing on the previous page.

1. Raise and safely support the front of your vehicle at a comfortable working level
2. Remove existing outer tie rod and adjuster leaving the inner tie rod.
3. Install the (5) Tie Rod Stud into your factory spindle using the (6)7/16" castle nut. Torque the nut to 35 ft lbs and install (8) cotter pin. **NOTE:** If none of the holes line up tighten the nut until you can get the hole to line up with a slot.
4. Install the (7) Right Hand thread nut onto the (1) heim end and (9) Left hand nut onto the factory tie rod.
5. Antiseize the threads on the factory tie rod and heim end to prevent the threads from galling.
6. The left hand threaded side of the (7) adjuster goes onto the factory tie rod; it has a groove cut into the end of the adjuster. You will want the thread engagement the same on the tie rod end and the heim, the easy way to do this is set then nut on the tie rod 1 1/4" from the end of the tie rod and thread the adjuster on so that it touches the nut.
7. Install the heim end into the other end of the adjuster. Start by threading the lock nut all the way on the heim end and thread the heim end into the adjuster so that it touches the nut.
8. Install the heim end side of the tie rod onto the tie rod stud using the (3) aluminum spacer on top and bottom of the heim end and then install the (4)5/8" lock nut. **Depending on spindle manufacture, a 2nd spacer made need to be installed on the bottom side of the heim end.** Torque nut to 35 ft lbs.
9. Set the center to center length of the tie rod assembly to 17 3/4" by turning the adjuster out. This will get you close on the toe setting but it will need to be aligned. **USE THE SIGHT HOLES IN THE SIDE OF THE TIE ROD ADJUSTER TO ENSURE PROPER THREAD ENGAGEMENT.**
10. Adjust the camber and toe roughly until you can get the vehicle to a proper alignment shop. The recommended alignment settings are:

Camber - -.5 to -1.5 [within .3 from side to side]

Caster – 4 to 7 degrees positive

Toe - 1/16" to 1/8" toe in

Feel free to experiment with alternative alignment settings that may be more appropriate for your particular driving style.

Installation notes:

- A. **MAKE SURE** that the cotter pins are properly installed in all appropriate places [C] to ensure that the castle nuts do not become loose and fail. These are VERY important connections!



Part # 11329120 - 1978-1988 GM G-Body Front SwayBar



Recommended Tools



1978-1988 GM G-Body Front SwayBar Installation Instructions

Table of contents

- Page 2..... Included Components and Hardware List
- Page 3-4..... SwayBar Installation

Hardware Torque Specifications

- M10-1.5..... 37 ftlbs
- 3/8"-16..... 30 ftlbs

www.ridetech.com 

REV2 5/22

Major ComponentsIn the box

Part #	Description	QTY
90001227	Front SwayBar	1
90002936	End Link Kit	1
90002513	Bushing Strap	2
70015015	Lined Sway Bar Bushing	2
90001254	Bushing Mount Adapter	2
70014210	Frame Brace Spacers	4

HARDWARE KIT.....99010085

QTY	Part Number	Description
ADAPTER PLATE		
2	99111001	M10-1.5 X 30MM Flat Head Bolt
2	99111002	M10-1.5 X 30MM Hex Head Bolt
2	99113001	M10 Split Lock Washer
2	99433002	7/16" SAE Flat Washer
1	90002263	Red Loctite

QTY	Part Number	Description
FRAME BRACE SPACERS		
4	99111004	M10-1.5 X 60MM Hex Head Bolt
2	99112002	M10-1.5 Nylok Nut
2	99113001	M10-1.5 X Split Lock Washer
6	99433002	7/16" SAE Flat Washer
BUSHING STRAP		
4	99371065	3/8"-16 x 3/4" Hex Bolt
4	99373002	3/8" Flat Washer
4	99373006	3/8" Split Lock Washer

Getting Started.....

Note: This sway bar kit utilizes a anti-friction lining in the sway bar bushing. The lining allows the sway bar to move freely and quietly in the bushing. No lubrication is required.

1. Jack the vehicle up to a safe working height and support with jack stands. Make sure the jack stands are stable before working under the car.
2. Remove the stock sway bar.
3. After removing the stock sway bar, determine what size hardware the frame will require.



4. If your car is equipped with front frame braces, remove them for now. They will get reinstalled later in the instructions.



5. Open the sway bar bushing at the split and slip it **OVER** the sway bar. Do this for both bushings.



6.

6. Slip the Bushing Straps over the SwayBar Bushings.



7.

FRONT
←

FLAT HEAD
SOCKET CAP
SCREW

7. Hold the Frame Plate up to the OEM holes, the Counter Sunk hole will be positioned over the front hole with the slot to the rear. Apply Red Loctite to the Flat Head Bolt. The rear 30mm long bolt uses a Split Washer and Flat Washer. Torque Hardware.



8.

8. Slide the SwayBar into position on the car with the SwayBar arms above the tie rods. Install a 3/8" Lock Washer & 3/8" Flat Washer on the 3/8"x 3/4" Hex Bolts. Do **NOT** Complete tighten the Hardware, it will be left partially loose until the End Links are installed.

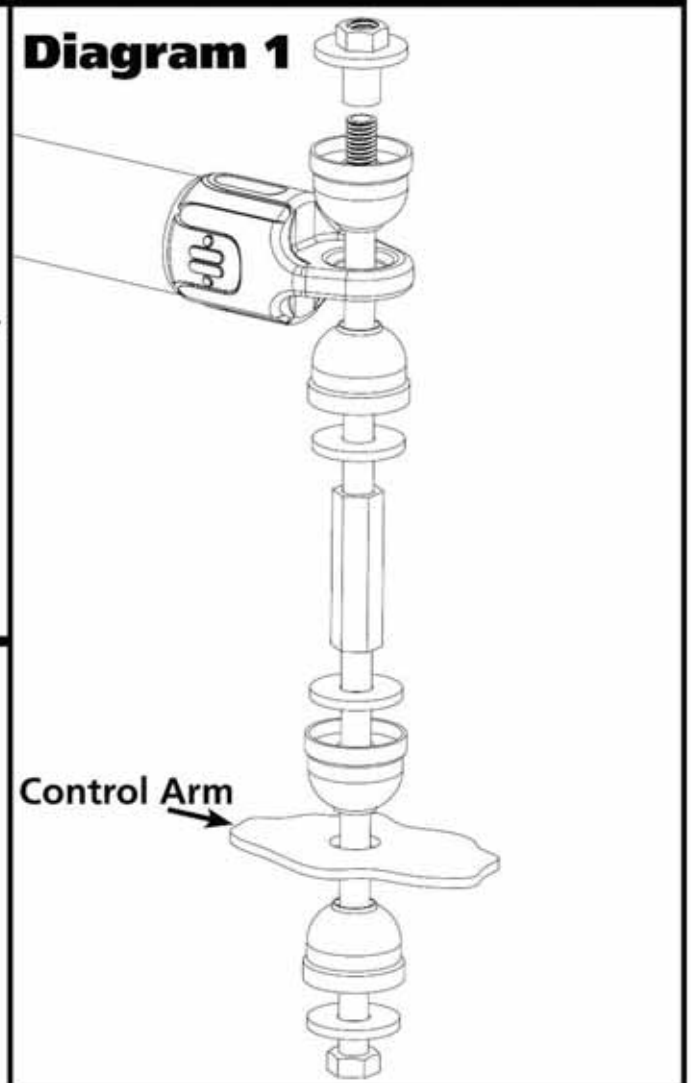

Diagram 1

Control Arm
→



9

9. Install the End Links using **Diagram 1** as a reference. Install both end links before tightening the end link hardware. Tighten the end link barrel nut until it is flush with the end of the bolt, and then tighten it 2 more complete rounds.

10. Torque the SwayBar mounting hardware.



11.

11. This swaybar requires the frame brace to be spaced down for clearance. Starting with the rear, install a flat washer, and lock washer on each of (2)M10-1.5 x 60mm bolts and insert them into the holes of the frame brace. Slide the Spacer onto the bolt with the SMALL diameter against the brace.

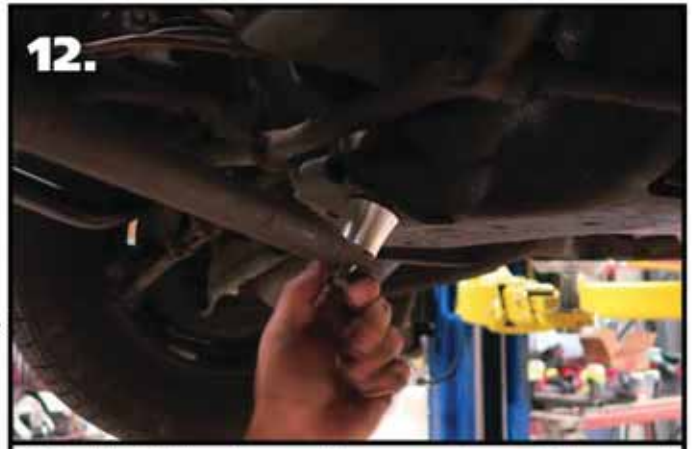

12.

12. Hold the Frame Brace up in position and thread the bolts into the OEM threaded holes. Leave them loose for now.



13.

13. Install a Flat Washer onto each of the (2) remaining M10-1.5 x 60mm bolts and insert them into the holes of the frame brace. Slide the Spacer onto the bolt with the SMALL diameter against the brace.



14.

14. Push the Brace up and line up the bolt with the OEM mounting holes. While holding the bolt in position, install a Flat Washer & M10-1.5 Nylok Nut on the bolt. You will have to insert them through the large hole in the bottom of the frame. Torque the frame brace hardware.



Part # 11227299 - GM A-Body & G-Body Differential R-Joint Bushing Removal/Installation



Recommended Tools



GM A-Body & G-Body Differential R-Joint Bushing Removal/Installation

Installation Instructions

Table of Contents

Page 2..... Included Components and Getting Started

Page 3-4..... Bushing Housing Installation

New R-Joints will be quite stiff (75-90 in/lbs breakaway torque) until they “break in” after a few miles of use. After the break in period they will move much more freely. Because the composite bearing race contains self lubricating ingredients, no additional lubrication is needed or desired. Any additional lubrication will only serve to attract more dirt and debris to the R-Joint and actually shorten its life.





Major ComponentsIn the box

Part #	Description	QTY
R-Joint Housing Components		
90002122	R-Joint Bushing Housing with R-Joint Components installed	2
70013784	R-Joint Spacers	4
R-Joint Components Installed In Housing		
70013275	R-Joint Center Ball	
70013276	R-Joint Composite Center Ball Cage	
70013279	Retaining Ring	
70013280	Wavo Wave Spring	
Bushing Removal & Installation Tool Components		
90002912	1.875" ID x 1.00" Long Notched Sleeve	1
90002880	1.825" OD Washer	1
90002913	2.625" OD Washer with Flat	1
90002559	2.375" ID x 2.375" Long Sleeve	1
99505003	1/2"-10 x 8" ACME Threaded Rod	1
99502013	1/2"-10 ACME Hex Nut	2
99503003	1/2" Flat Washer	2

Getting Started.....

This kit is designed to aid in the removal of the OEM bushings and installation of the Delrin R-Joint Axle Housing Bushing. This guide will show you how the kit is to be used. It is important to not get the bushings crooked on installation.

2.

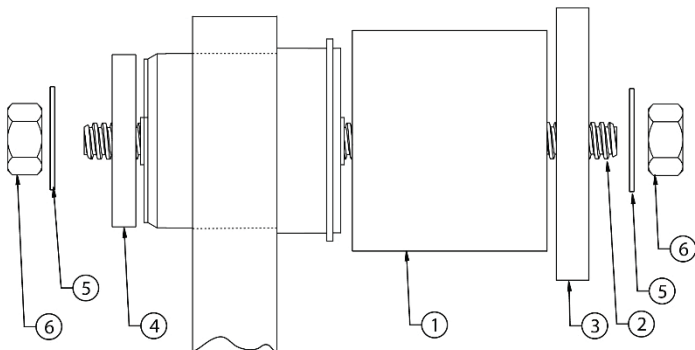

1. Start by sticking the 2 3/8" Sleeve(1) over the OEM bushing. Insert the 1/2"-10 x 8" Threaded Rod(2) into the OEM bushing. Install the Large 2 5/8" Diameter Flat Sided Washer(3) onto the threaded rod on the Sleeve side. Install the Small 1.825" Washer(4) on the threaded rod (on the side with the bushing sticking through the housing). Install a 1/2" washer(5) and nut(6) on each end of the threaded rod. Use **Images 1 & 2** as a reference.



Bushing Housing Installation

2.

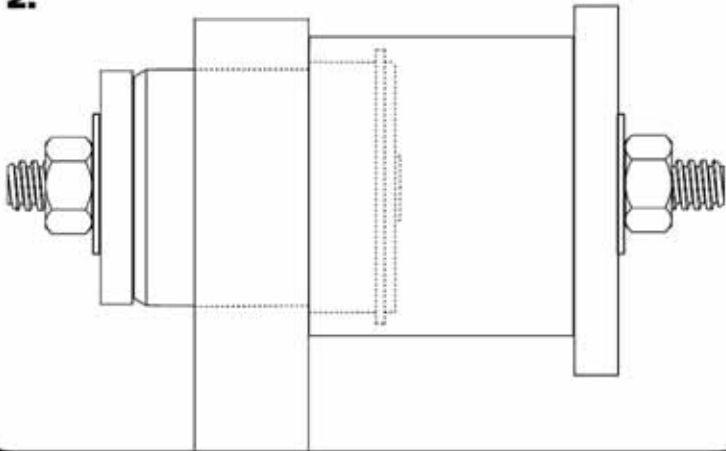

2. Tighten the 1/2" nuts, pushing the bushing out of the mount.

3.

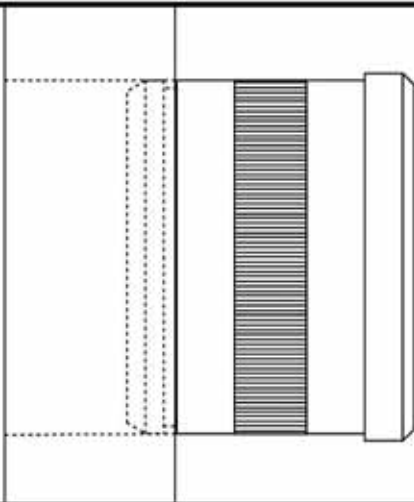

3. Start the R-Joint Housing into the OEM bushing hole by hand.

4.

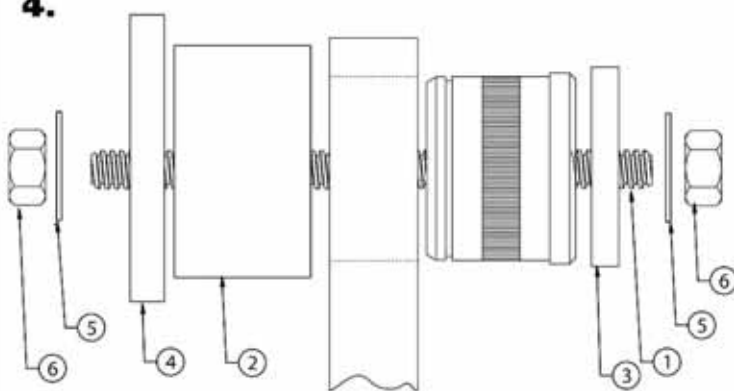

4. Insert the 1/2"-10 x 8" Threaded Rod(1) into the bushing. Install the 1 7/8" ID x 1" Long Sleeve(2) on the opposite side of the bushing. This sleeve will be centered over the bushing hole. Install the 1.825" Washer(3) on the stud (on the bushing side). Install the 2 5/8" Flat Sided Washer(4) on the 1 7/8" Sleeve side. Install a 1/2" washer(5) and nut(6) on each end of the threaded rod. Use **Images 4-7** as a reference. **12 BOLT DIFFERENTIALS REQUIRE A SPECIFIC ORIENTATION OF THE 1" LONG SLEEVE AND THE FLAT SIDED 2 5/8" WASHER. IMAGES 5 & 6 ILLUSTRATE THE ORIENTATION.**



Bushing Housing Installation



5. 12 BOLT ONLY When installing the R-joint in a 12 bolt, the orientation of some components of the installation tool is important. **Image 5** is of the 1 7/8" ID x 1" Long Sleeve. The sleeve has a notch cut in each side of it. One side has a wide, shallow notch. The other side has a narrow, deep notch. A 12 bolt requires the wide, shallow notch to be up against the bushing ear of the axle. The narrow, deep notch is for clearance of the axle housing. The deep notch will need to be positioned so that the housing isn't pushing against the sleeve, causing it to not sit flat against the ear of the axle.



6. 12 BOLT ONLY The 2 5/8" Flat Sided Washer is made with a FLAT in it to clear the axle housing while installing the r-joint housing. You will need to position the Flat Sided Washer so it isn't hitting against the axle housing.

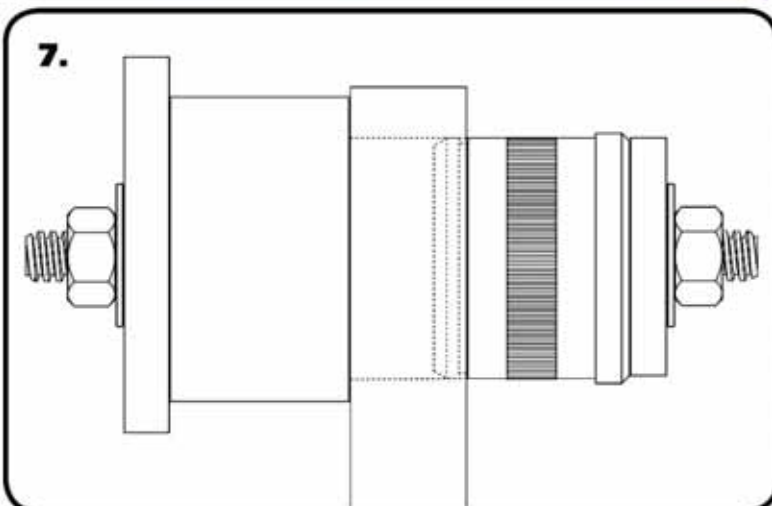

7. Snug down the nuts enough to hold the sleeve and washers in place. Check to make sure the sleeve is centered over the hole and the 1.825" washer is center on the bushing housing. If installing in a 12 Bolt Housing, refer to **Steps 5 & 6** for proper orientation of the installation tool. Tighten the nuts to press the bushing housing into the axle housing. Tighten the nuts until the housing bottoms in the axle mount.



Bushing Housing Installation

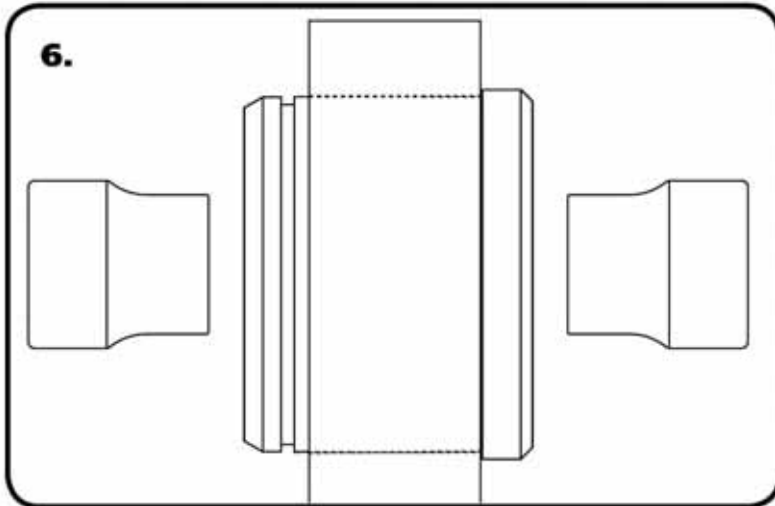

8. Install the Spacers by inserting the SMALL side of the SPACER into the Center Pivot Ball. Push them in until they bottom out and stop.

9. Install your Ridetech StrongArms. Refer to the instructions supplied with the StrongArms.



Part # 11326699 - 1978-1988 GM "G"-Body Rear Upper StrongArm Kit



Recommended Tools



1978-1988 GM "G"-Body Rear Upper StrongArms Installation Instructions

Table of contents

Page 2..... Included Components
Page 3..... StrongArm Installation

WE RECOMMEND REPLACING THE BUSHINGS IN YOUR AXLE HOUSING WITH THE RIDETECH AXLE HOUSING R-JOINTS, PART NUMBER 11227298.



www.ridetech.com



REV2 5/5/20



Included ComponentsIn the box

Part Number	Description	QTY
90001118	Upper Control Arms (Set to 11.125")	2
90001318	RH R-Joint Threaded Housing Assembly (Installed in bars)	2
99752004	3/4" -16 Jam Nut (Installed on R-Joint End	2
70013784	R-Joint Spacers	4
R-Joint Components - (Installed in R-Joint ends)		
70013275	R-Joint Center Ball	2
70013276	R-Joint Composite Center Ball Cage	2
70013279	Retaining Ring	2
70013280	Wavo Wave Spring	2

Hardware Kit# - 99010096

99501005	1/2" -13 x 3 1/2" Hex Bolt	Upper StrongArm	4
99502009	1/2" -13 Nylok Nut	Upper StrongArm	4
99503014	1/2" SAE Flat Washer	Upper StrongArm	4

R-JOINT SPACER INSTALLATION

Install the Spacers by inserting the SMALL side of the SPACER into the Center Pivot Ball. Push them in until bottom out and stop.

UPPER R-JOINTS

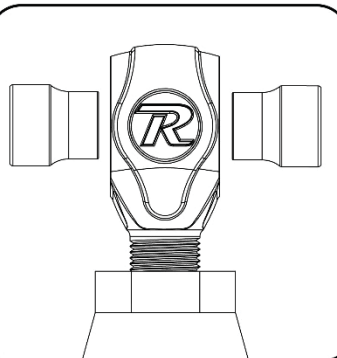

New R-Joints will be quite stiff (75-90 in/lbs breakaway torque) until they "break in" after a few miles of use. After the break in period they will move much more freely. Because the composite bearing race contains self lubricating ingredients, no additional lubrication is needed or desired. Any additional lubrication will only serve to attract more dirt and debris to the R-Joint and actually shorten its life.

STRONGARM ORIENTATION

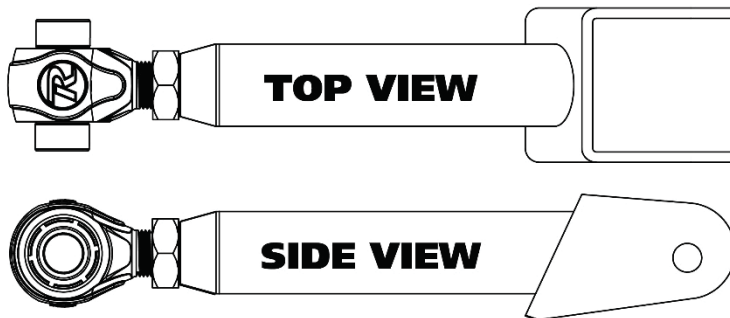

THIS ILLUSTRATION SHOWS HOW THE UPPER STRONGARM IS TO BE INSTALLED IN YOUR G-BODY.



StrongArm Installation

1.

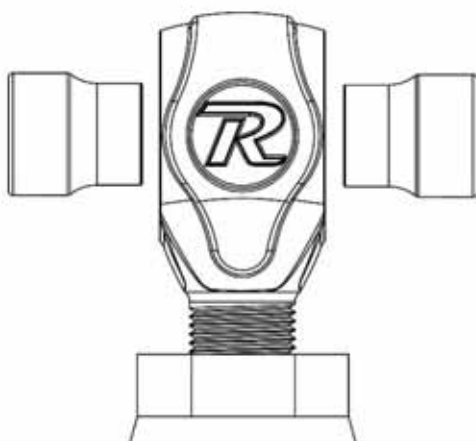

1. Remove the OEM upper control arm. Inspect the condition of the bushings in the axle housing. We recommend the Ridetech Axle Housing R-joints #11227298 for bind free suspension movement. If you are also installing the Axle Housing R-Joints, install them before installing the new upper StrongArms. Check the length of the upper StrongArm, it should be set at 11.125". Ensure that the jam nut is tight. Insert the R-Joint Spacers into the R-Joint by installing the small end of the spacers into the R-Joint. Push them in until they bottom out and stop.

2.



2. Insert the R-Joint end of the upper StrongArm into the OEM location, making sure the StrongArm is positioned correctly. Use the illustration on **Page 2** to help determine the correct orientation. Line up the through hole of the R-joint with the upper control arm mounting holes. Insert a 1/2"-13 x 3 1/2" hex bolt through the holes. Install a 1/2" flat washer and 1/2"-13 nylok nut on the threads of the bolt sticking through the frame. Torque to 75 ftlbs.

3.



3. Slip the end of the upper Strongarm over the axle housing bushing. Line up the holes of the StrongArm with the through hole of the bushing. Insert a 1/2"-13 x 3 1/2" hex bolt through the holes. Install a 1/2" flat washer and 1/2"-13 nylok nut on the threads of the bolt sticking through the frame. If you are reusing the OEM rubber bushing, do not tighten until the car is sitting at ride height. If you have the axle housing R-Joint installed, you can tighten the hardware with the suspension hanging. Torque the hardware to 75 ftlbs.



Part # 11324499 - 1978-1988 GM "G"-Body Rear Lower StrongArm Kit

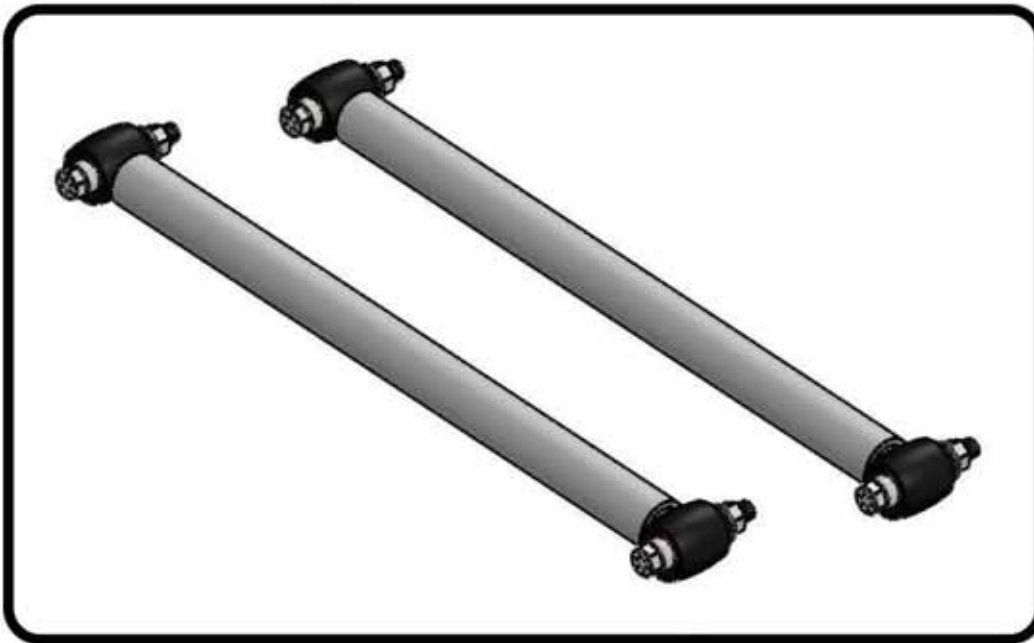

Recommended Tools



1978-1988 GM "G"-Body Rear Lower StrongArms Installation Instructions

Table of contents

Page 2..... Included Components & Hardware
Page 3..... Installation





Included ComponentsIn the box

Item #	Part Number	Description	QTY
1	90002858	Lower Control Arms	2
2	70013784	1/2" ID R-Joint Spacer	8
R-Joint Components - (Installed in bar ends)			
	70013275	R-Joint Center Ball	4
	70013276	R-Joint Composite Center Ball Cage	4
	70013279	Retaining Ring	4
	70013280	Wavo Wave Spring	4
Hardware Kit #99010096			
3	99501005	1/2"-13 x 3 1/2" Hex Bolt	4
4	99502009	1/2"-13 Nylok Nut	4
5	99503014	1/2" SAE flat Washer	4

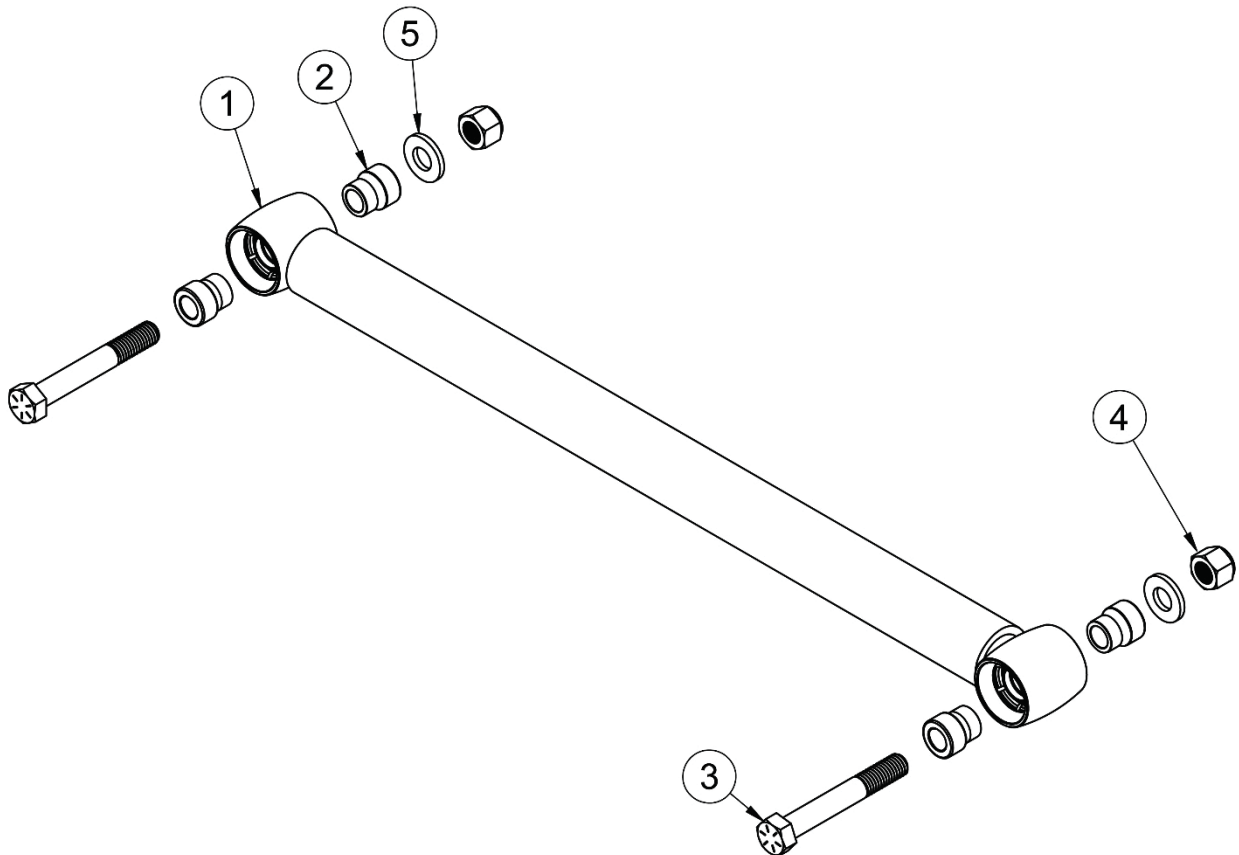



StrongArm Installation

R-JOINT SPACER INSTALLATION

Install the Spacers by inserting the SMALL side of the SPACER into the Center Pivot Ball. Push them in until they bottom out and stop.

UPPER R-JOINTS

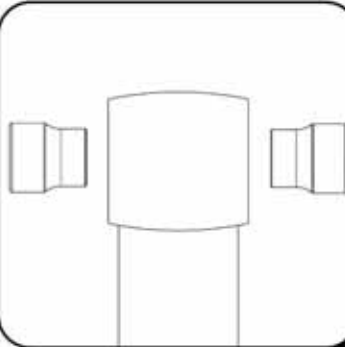

New R-Joints will be quite stiff (75-90 in/lbs breakaway torque) until they "break in" after a few miles of use. After the break in period they will move much more freely. Because the composite bearing race contains self lubricating ingredients, no additional lubrication is needed or desired. Any additional lubrication will only serve to attract more dirt and debris to the R-Joint and actually shorten its life.

1. Remove the factory lower trailing arm. Do one side at a time to keep the axle from rotating.



2. Insert the Spacers into the R-Joints. Refer to the above diagram.

3. Attach to front on the lower StrongArm to the frame using the 1/2" x 3 1/2" bolts and Nylok nuts supplied.



4. Attach to rear of the lower StrongArm to the frame using the 1/2" x 3 1/2" bolts and Nylok nuts supplied.

Note: Tighten the hardware to 75 ft-lbs.



350 S. St. Charles St. Jasper, In. 47546
Ph. 812.482.2932 Fax 812.634.6632

www.ridetech.com

Part # 11325401
78-88 GM "G" Body Rear ShockWave Kit
Single Adjustable

Shockwave Assembly:

2	982-10-802	5" stroke single adjustable shock
2	24090799	7000 Series sleeve assembly
2	234-00-153	Locking ring for bellow
2	815-05-022	1.7" Eyelet –adjustable
4	90001994	.625" bearing
8	90001995	Bearing snap ring

Components:

8	90002043	Aluminum spacer - .5" I.D.
2	90002327	Upper shock bracket
1	90002325	Driver side lower shock bracket
1	90002326	Passenger side lower shock bracket
2	90002158	Lower Shock Bracket

Hardware:

4	99311001	5/16"-18 x 1" Gr. 5 bolt	Upper bracket to frame
4	99312003	5/16"-18 Nylok nut	Upper bracket to frame
8	99313002	5/16" SAE flat washer	Upper bracket to frame
2	99501027	1/2"-13 x 3 3/4" Gr. 5 bolt	Shock bracket to trailing arm bracket
6	99501002	1/2"-13 x 1 1/2" Gr.5 bolt	Shock bracket
4	99501003	1/2"-13 x 2 1/2" Gr. 5 bolt	Shock to upper & lower brackets
12	99502001	1/2"-13 Nylok nut	Lower shock bracket
8	99503001	1/2" SAE flat washer	Lower shock bracket

SHOCKwave®

Installation Instructions

1. Raise and safely support the vehicle by the frame rails.
2. Using a jack, slightly raise the axle approximately 1". Remove the shock absorbers.
3. Lower the axle down enough to remove the coil springs.
4. The exhaust tail pipes may need to be removed and/or modified for Shockwave installation.



5. Fasten the new upper shock bracket into the factory shock location using the 5/16" x 1" bolts, flat washers and Nylok nuts supplied.

Note: Position the bracket to offset the shock toward the center of the car.



6. Remove the lower trailing arm mounting bolt. (Do one side at a time to keep the axle from rotating).

7. Place the new lower shock bracket up against the factory lower shock bracket. Use a 1/2" x 1 1/2" bolt, Nylok nut and flat washers to fasten the new bracket to the factory bracket. Install the longer 1/2" x 3 3/4" bolt through the lower trailing arm mount, secure w/ the supplied flat washers and Nylok nuts.

SHOCKwave®

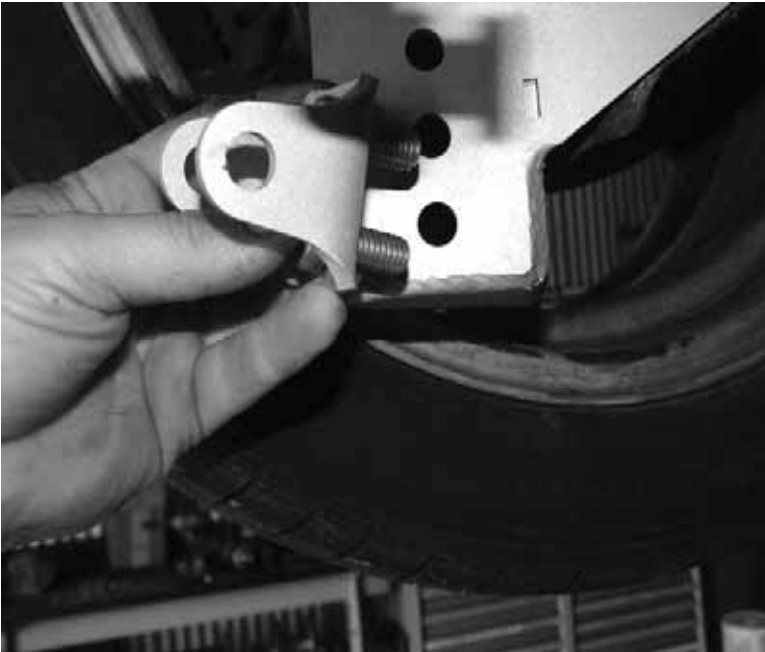

8. Install the Lower Bolt on Shock Bracket in the top 2 holes using (2) $\frac{1}{2}$ " x $1\frac{1}{2}$ " Hex Bolts, and (2) $\frac{1}{2}$ " Nylok Nuts.

The lower Bracket has 3 holes. The top 2 holes are the holes that the kit will normally use. If a lower ride height is desired, the bottom 2 holes can be used.



9. Install the aluminum spacers into the upper and lower eyes of the shock.



10. The air fitting location can be rotated by twisting the bellow separate of the shock.

11. Fasten the ShockWave to the upper bracket using a ½" x 2 ½" bolt and Nylok nut.

12. Fasten the ShockWave to the lower bracket using a ½" x 2 ½" bolt and Nylok nut.

13. Double check air spring clearances throughout full suspension travel.

14. Ride height on this ShockWave is 14.5" from center eye to center eye.

Shock adjustment 101- Single Adjustable

Rebound Adjustment:

How to adjust your new shocks.

The rebound adjustment knob is located on the top of the shock absorber protruding from the eyelet.

You must first begin at the ZERO setting, then set the shock to a soft setting of 20.



-Begin with the shocks adjusted to the ZERO rebound position (full stiff). Do this by rotating the rebound adjuster knob clockwise until it stops.

-Now turn the rebound adjuster knob counter clock wise 20 clicks. This sets the shock at 20. (settings 21-24 are typically too soft for street use).

Take the vehicle for a test drive.



-if you are satisfied with the ride quality, do not do anything, you are set!

-if the ride quality is too soft increase the damping effect by rotating the rebound knob clock wise 3 clicks.

Take the vehicle for another test drive.



if the vehicle is too soft increase the damping effect by rotating the rebound knob clock wise 3 additional clicks.

-if the vehicle is too stiff rotate the rebound adjustment knob counter clock wise 2 clicks and you are set!

Take the vehicle for another test drive and repeat the above steps until the ride quality is satisfactory.

Note:

One end of the vehicle will likely reach the desired setting before the other end. If this happens stop adjusting the satisfied end and keep adjusting the unsatisfied end until the overall ride quality is satisfactory.



Part # 11329122 - 1978-1988 GM G-Body Rear SwayBar

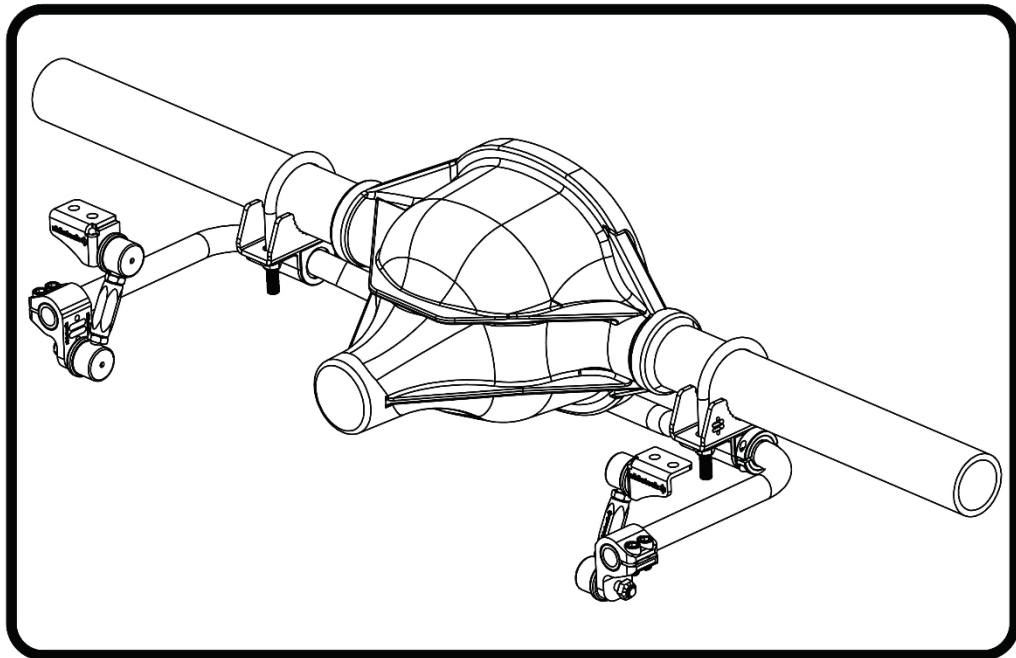

Recommended Tools

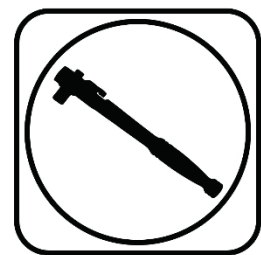

1978-1988 GM G-Body Rear SwayBar Installation Instructions

Table of contents
Page 2..... Included Components and Hardware List
Page 3-4..... SwayBar Installation

Hardware Torque Specifications

3/8"-16.....	30 ftlbs
7/16"-20.....	55 ftlbs
M10-1.5.....	37 ftlbs



Major ComponentsIn the box

Part #	Description	QTY
90001237	Rear SwayBar	1
90001261	Axle Bracket, 2.5" Axle Tube	2
90001250	Bushing Strap	2
70015012	Lined Sway Bar Bushing	2
90001251	Frame Tab, Driver	1
90001252	Frame Tab, Passenger	1
70014301	Clamp Ring	2
70014207	Clamp On SwayBar End	2
90002571	10mm 90 Degree End Links	4
90001262	SwayBar End Link Spacer, 2 1/8"	2
99436003	7/16" U-bolt, 2 1/2" Axle Tube	2

HARDWARE KIT99010084

QTY	Part Number	Description
SWAYBAR TO AXLE		
4	99433002	7/16" SAE Flat Washer
4	99432002	7/16"-20 Nylok Nut
SWAYBAR END CLAMP		
4	99371054	3/8"-16 x 7/8" Socket Head Bolt

QTY	Part Number	Description
TAB TO FRAME		
4	99371005	3/8"-16 x 1 1/4" Hex Bolt
4	99373002	3/8" Flat Washer
4	99372001	3/8"-16 Nylok Nut

3" AXLE TUBE NOTE:

The stock differential has 2 1/2" axle tubes. If you have an aftermarket differential you will need:

- (2) 90001249 Axle Bracket, 3.0" Axle Tube
- (2) 90000088 7/16" U-bolt, 3" Axle Tube

Getting Started.....

This sway bar kit utilizes a anti-friction lining in the sway bar bushing. The lining allows the sway bar to move freely and quietly in the bushing. No lubrication is required.

THIS SWAYBAR ATTACHES TO THE AXLE AND FRAME.

1. Jack the vehicle up to a safe working height and support with jack stands. Make sure the jack stands are stable before working under the car.
2. Remove the stock sway bar if the car is equipped with one.



3. Open the sway bar bushing at the split and slip it **OVER** the sway bar. Do this for both bushings.



4. Install the bushing straps over the sway bar bushings.



5. Install the u-bolts onto the axle tube with the threads pointing down. You may need to raise the brake lines in the area of the u-bolts. The u-bolts will be approximately 23 1/2" apart and equal distance on each side from the brake backing plates.



6. Install an axle bracket onto each u-bolt with the flat side to toward the ground. The "teeth" of the mount should touch the axle tube.

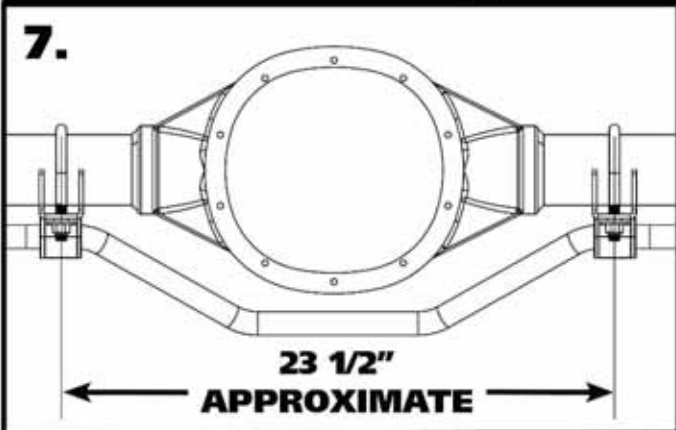

7. Diagram 7 illustrates the correct installation of the sway bar. Again, the axle brackets will be approximately 23 1/2" from center to center. The mounts should be spaced equal amounts from the brake backing plates, centering the sway bar on the axle.



8. Hold the sway bar in position on the car with the center bend toward the ground. Install a 7/16" flat washer & 7/16"-20 nylok nut on the threads of the u-bolts. Snug the hardware down and verify that it is centered and the axle mounts are level. Torque the u-bolt hardware.



9. Thread (2) 3/8"-16 x 7/8" Socket Head Cap Screws into each of the Clamp-On Ends. Install a clamp-on end on each end of the bar. The End Link mounting hole should be mounted to the inside of the bar and pointing down. Start with the mount flush with the end of the bar.

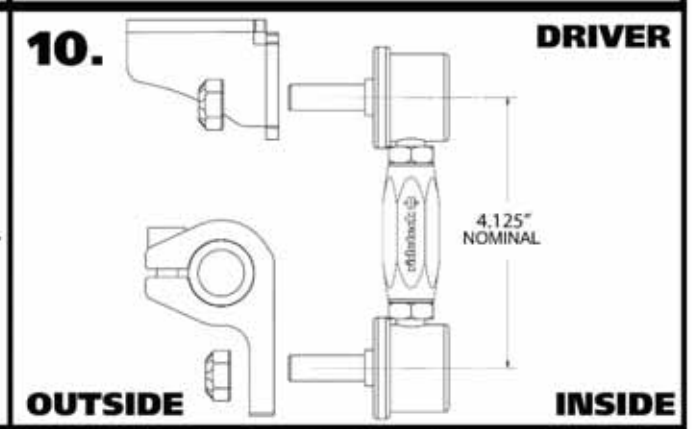

10. Set the Linkage to 4 1/8" center to center with the threaded studs pointed the same direction. Snug the jam nuts against the center adapter. Attach the SwayBar Linkage to the Clamp-On Mount using the hardware on the linkage. Attach the correct tab to the top of the linkage with the gusset to the front. Use Diagram 10 as a reference. Attach the linkages and tab to both sides.

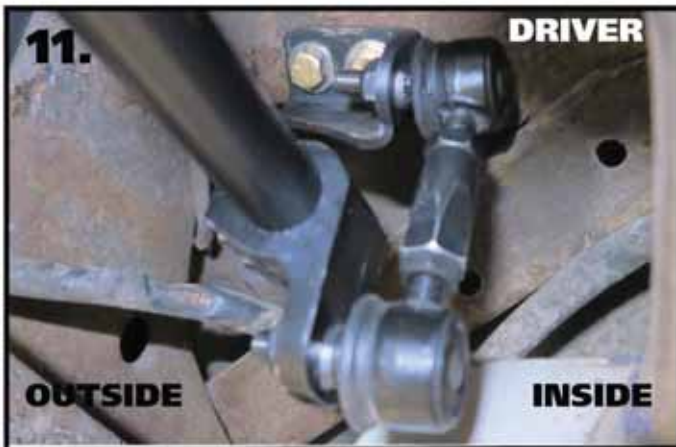

11. Swing the tab up to the frame, keeping the linkage straight from side to side. Use the tab to mark the location of the holes that will need to be drilled. Drill the holes with a 3/8" drill bit. Install a 3/8" flat washer on each of (2) 3/8"-16 x 1 1/4" hex bolts and install them through the bracket and drilled holes. Install a 3/8" flat washer & 3/8"-16 nylok nut on each bolts sticking through the frame. Torque the hardware and repeat on the other side.



12. Install the locking rings on the outside of each bushing assembly. Use a hex key to take the locking ring apart. Reassemble it on the bar positioned next to the outside of the bushing assembly. Push the locking ring up against the bushing assembly and tighten.

13. MINIMUM RATE 200 LB/INCH

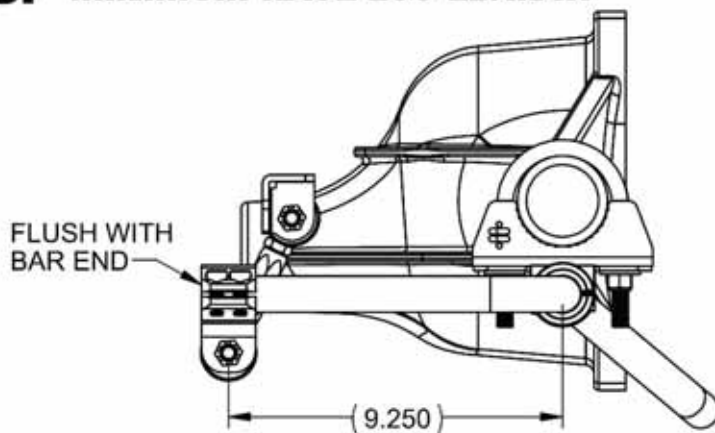

HIGH RATE 350 LB/INCH

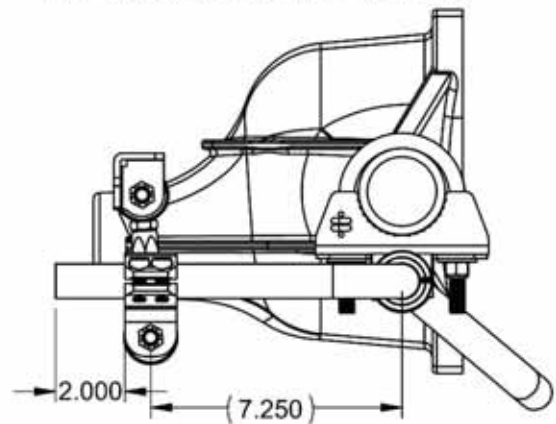

13. We recommend getting the swaybar as level as possible at ride height and with no preload. Both of these steps are done by adjusting the end links. These end links can be adjusted from 4 1/8" to 4 7/8". Disconnect the end links from the swaybar and adjust one side to get the swaybar level. Reattach the end link to the swaybar and adjust the 2nd end link so that it goes in and out of the clamp-on mount with ease. This will be zero preload.

The rate of this sway bar is also adjustable. This is possible by changing the position of the clamp-on ends on the bar. The standard setting is with the clamp-on mounts even with the end of the bar, stiffest is with the clamp-on end positioned 3" from the end of the swaybar. The Diagram above shows the clamp-on mount in the softest and stiffest settings. The position of the mounts will be determined by several factors; spring rate, front bar size, and even tire size. We recommend running this rear sway bar with Ridetech's front sway bar (11329120) for the best performance.