



# INSTALLATION GUIDE

**PART NUMBER: 25021**  
**FRONT LOWERING STRUT**  
**FORD RANGER 2WD / 4WD | 2019+**

-1" TO -2.75" HEIGHT ADJUSTABLE LOWERING

300 W. PONTIAC WAY. CLOVIS, CA 93612  
PHONE: 800-445-3767 | EMAIL: [INFO@BELLTECH.COM](mailto:INFO@BELLTECH.COM)

# THANK YOU

Thank you for choosing our high quality Belltech product. We have spent a great deal of time developing our line of products so that you will receive maximum performance with minimal difficulty during installation. Soon your vehicle will be on the road looking and feeling much improved.

**Please take a moment to read all instructions and warnings prior to installation of your new Belltech product and before operating your vehicle. If you have any questions or concerns regarding any step in the installation process, please do not hesitate to call or email our customer support specialists who are trained to help you through any portion of this process.**

## Before You Begin:

**It is of the utmost importance that you confirm all of the components listed on the parts list is in the kit. You can find this list located on the last page(s) of your instructions. Do not begin installation if any part is missing. Instead, please call our Belltech customer service specialists.**

### **Belltech Customer Support:**

**Phone: 1-800-445-3767**

**Email: [info@belltech.com](mailto:info@belltech.com)**

## Safety Information:

**Warning:** Do not work under a vehicle supported only by a jack. Place support stands securely under the vehicle in the manufacturer's specified locations unless otherwise instructed.

Proper use of safety equipment and eye/face/hand protection is absolutely necessary when performing any of the following instructions.

We strive for an exceptional experience for all our valued customers. If for any reason you need assistance with your Belltech products, please do not return the product to the store you purchased from, but rather call our dedicated customer service experts, from 7am to 5pm PST.

We recommend that a qualified mechanic, at a properly equipped facility, perform this installation.

It is very helpful to have an assistant available during installation.

## Before Driving Your Vehicle:

It is important to double check all brake hoses, cables, and other components to be sure there is no interference. You must also check for wheel/tire to chassis/body interference. If any issues are found, review your installation instructions to be sure no steps were missed and any problems are corrected.

Make sure your vehicle is aligned immediately following installation.

Check all hardware and re-torque at intervals for the first 10, 100, and 1000 miles.

Some of Belltech's products are designed to improve your vehicle's off-road performance. Leveling/lifting your vehicle may result in an altered center of gravity. It is crucial to use extreme care when operating your vehicle to prevent rollover and/or loss of control.

Any changes in your vehicle's suspension may result in transformed handleability. Please test-drive your vehicle in a remote location so you can become accustomed to the revised driving characteristics.

Perform headlight check and adjustment.

Failure to drive any modified vehicle in a safe manner may result in harm or death.

Never operate your modified vehicle under the influence of drugs, alcohol, or lack of adequate sleep.

Always wear your seatbelt.



**DIFFICULTY:**

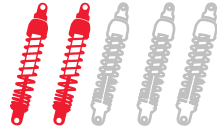

**INSTALLATION TIME:**

2-4 Hours + Alignment

## RECOMMENDED TOOLS:

- Properly rated floor jack
- Support stands
- Wheel chocks
- Metric socket wrench set
- Metric wrench set
- Tape measure
- Marking Pen

## SPECIALTY TOOLS:

- High quality spring compressor
- Torque wrench up to 150 ft lbs.

## FITMENT NOTE:

There will be mild vibrations starting at 70 MPH for 4WD applications.

There will be an increase in wear and tear on the front drivetrain in 4WD applications; KW North America is not liable wear and tear on the drivetrain.

**DO NOT** drive your 4WD vehicle over 50 mph / 80 km/h while in 4H Auto/ 4H.

## INSTALLATION PREPARATION:

Before beginning the installation process, measure the hub to fender heights for your vehicle and record them in the “Before” section. After your vehicle has been modified, record the new measurements in the, “After” section. This way, you can compare the resulting height to the original. When taking the measurements, measure vertically from the center of the wheel to the inner edge of the fender.

**Before:**

LF: \_\_\_\_\_

RF: \_\_\_\_\_

LR: \_\_\_\_\_

RR: \_\_\_\_\_

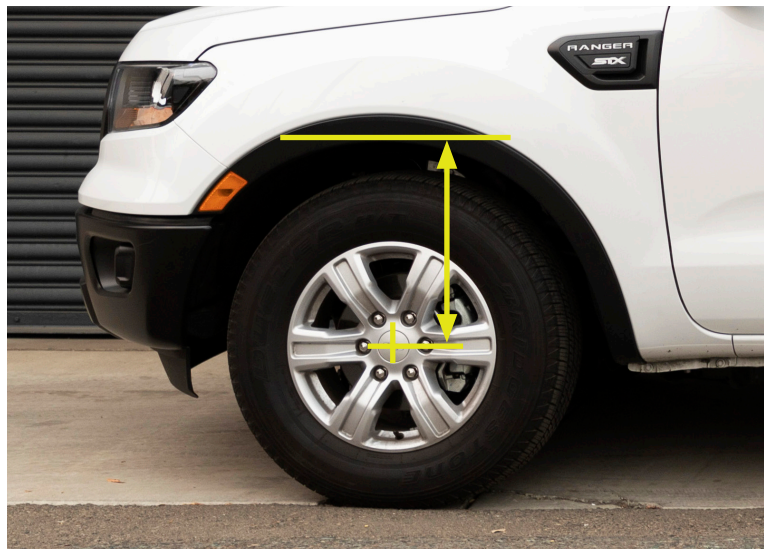

**After:**

LF: \_\_\_\_\_

RF: \_\_\_\_\_

LR: \_\_\_\_\_

RR: \_\_\_\_\_

# JACKING, SUPPORTING, AND PREPARING THE VEHICLE

1. Park your vehicle on a smooth, level, concrete or seasoned asphalt surface.
2. Block the rear wheels of the vehicle using wheel chocks. Make sure the vehicle's transmission is in "PARK" (automatic) or 1st gear (manual).
3. Activate the parking brake.
4. Break loose, but do not spin the wheel lug nuts to ease in removal when the wheels are in the air.
5. Lift the front of the vehicle off the ground using a properly rated floor jack. Lift the vehicle so the front tires are approximately 6-8 inches off the ground.
6. Place support stands rated for the vehicles weight. The stands should be positioned in the factory specified locations (Refer to the owners manual). Prior to lowering the vehicle onto stands, make sure the support stands will contact the chassis. It is very important that the vehicle is properly supported to prevent any harm to ones self or to the vehicle.
7. Lower the vehicle slowly onto the stands.
8. Remove the front wheels.



## Technician reminder:

Never work under a vehicle supported only by a jack. It is necessary to place support stands securely under the vehicle in the manufacturer's specified locations unless otherwise instructed.

## OEM STRUT REMOVAL

9. Before removing any component, use a marking pen mark the alignment cams to reference placement later.



10. Using a hex key and a 18mm wrench, remove the upper nuts to dismount the end links from the spindles to allow articulation while working on the suspension.



11. Disconnect the brackets holding the brake lines and ABS sensors to the spindle and detach the clips holding the lines to the control arms.

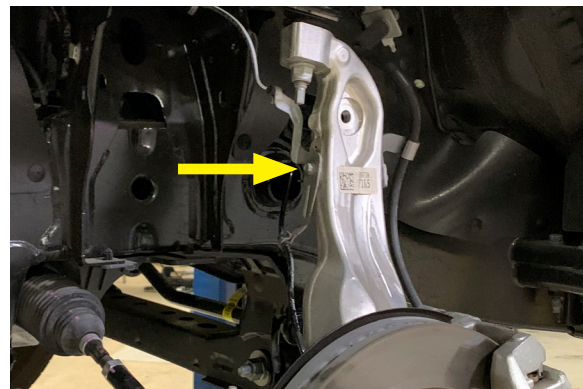

### Technician reminder:

Before removing or drooping any suspension components ensure no wires, ABS lines, or brake hoses are damaged from being overstretched. Please ensure there is enough slack during installation.

## OEM STRUT REMOVAL CONTINUED

12. Working on one side at a time, loosen and remove the lower control arm bolt with a 21mm wrench and a 24mm wrench.



13. Remove the 18mm nuts securing the lower strut mount to the lower control arm.



14. Push the spindle and lower control arm down and away until the lower shock studs are clear of the control arm.



## OEM STRUT REMOVAL CONTINUED

15. Remove the three 15mm nuts securing the top of the strut to the chassis and remove the strut assembly from the vehicle.



## OEM STRUT DISASSEMBLY

16. Using a proper spring compressor, mount the strut assembly and ensure it is secured before proceeding. To ease the installation of the new strut, mark the position of the top mount in relationship to the upper spring isolator and strut body. Compress the spring until tension is relieved from the strut.



### Technician note:

The coil spring is held in place under extreme compression. **Belltech** recommends the use of a heavy-duty spring compressor suitable for truck springs to perform the following steps. If unsure of your spring compressor capabilities, please take your struts to a professional installer. Use caution during the following steps to avoid personal injury and/or damage to the vehicle.

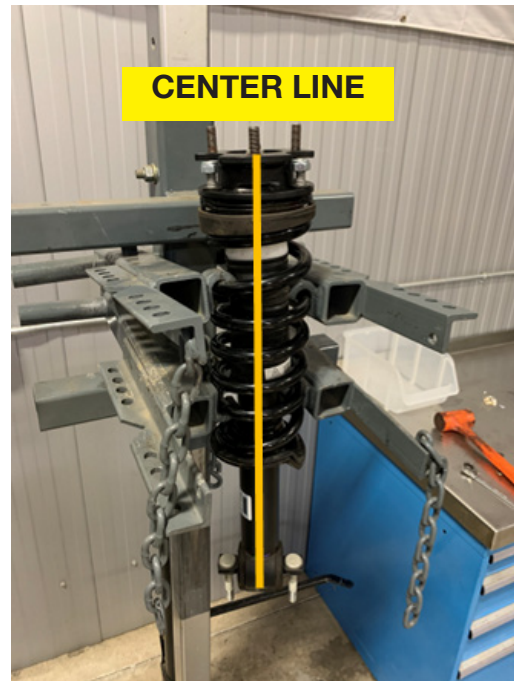

17. Compress the spring until tension is relieved from the strut. Remove top nut, top mount, both spring isolators, and strut. You will use the top mount and both spring isolators with your new Belltech strut.
18. Do not remove the original spring from the compressed spring fixture.



# BELLTECH STRUT ASSEMBLY

19. The strut is delivered as shown below. Remove the Nyloc nut from the top of the Belltech strut to proceed.



## Technician note:

When raising your vehicle more than 1", OE camber may not be achievable. Ensure proper toe alignment to minimize tire wear.

20. Using the tables below as reference, remove the main spring and slide the required packers onto the strut rod.

2019+ Ford Ranger 2WD / 4WD			
Drop (Inches)	7.5mm Ring Spacer	15mm Ring Spacer	15mm Packer
1"	1	2	1
2"	0	1	0
2.75"	0	0	0

21. Transfer the plastic lower spring isolator from original perch to the new Belltech perch. Install the spring perch over the lift rings onto the strut. Do not install the spring perch upside down.





## BELLTECH STRUT ASSEMBLY CONTINUED



### Ventilation Disk Installation Warning:

When assembling the Belltech shock/strut, make note of the orientation of the supplied Belltech ventilation disk. It has two sides: a flat side and an air-channeled side. The air-channeled side **MUST** be facing downward toward the shock/strut and the flat side toward the bump stop (See figures 1A and 1B).

Failure to do this, will result in shock/strut damage.

22. Slide the vent disk on the strut rod. Ensure the air-channeled side facing down as shown in the images below.

**Air-channels face down toward strut**

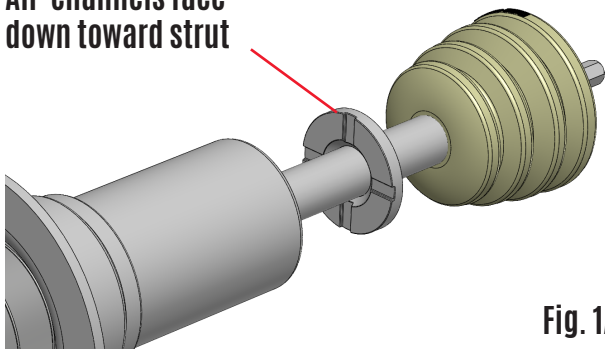

Fig. 1A

**Flat surface faces up toward bump stop**

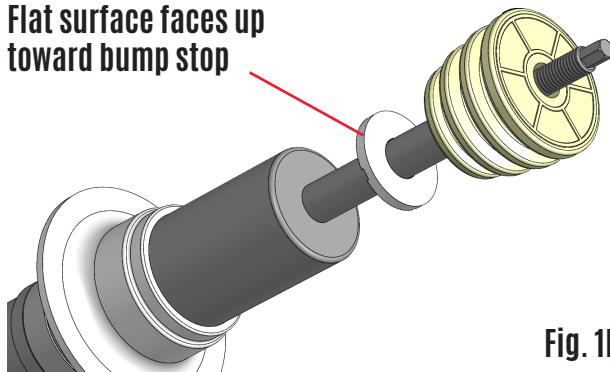

Fig. 1B

23. Slide the required packers onto the strut rod.



### Technician note:

Belltech uses packers to maintain the correct bump stop engagement at various height ranges. Using the appropriate packer will prevent excessive body roll. If a packer is needed, according to the chart on the page 4, please place the packer on top of the vent disc, channel side down, as shown by the image to the right of this text box.

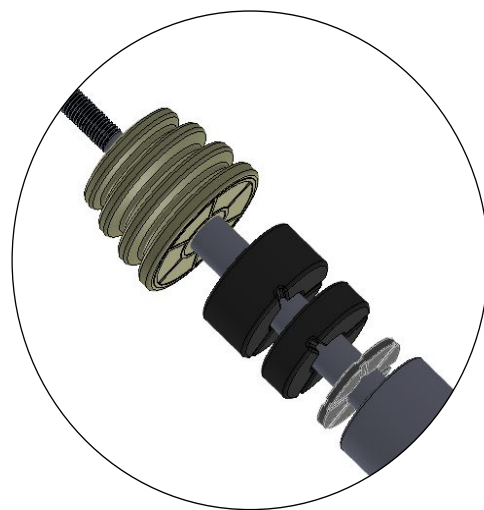

24. With the OEM spring still compressed, slide the new Belltech strut into the OEM spring and install Belltech bump stop on the strut rod.
25. Complete the assembly using the OEM top spring isolator, top mount, and supplied Nyloc nut.
26. Align the top mount with the spring using the original marking made in step 16. Torque the strut rod nut to 41 ft lbs.

## BELLTECH STRUT INSTALLATION

27. Install the top mount into the chassis and secure the strut assembly with the three OE nuts. Torque to 41 ft lbs.



28. Attach the lower strut mount to the lower control arm using the supplied flanged nuts and bolts. Torque to 66 ft lbs.

29. Attach the lower control arm to the chassis using the OE alignment hardware. Do not tighten or torque until your vehicle is back on the ground or the suspension is loaded.

30. Attach the ABS line to the spindle, torque to 53 *in lbs*. Attach the brake hose brackets to the spindle, torque to 159 *in lbs*.

31. Using a hex key and a 18mm wrench, attach the upper end link nuts to the spindles, torque to 85 ft lbs.

32. Set the alignment settings to the markings made before installation and torque to 195 ft lbs.



# FINALIZING THE INSTALLATION

32. Mount the wheels and tighten the lug nuts.
33. Lift the vehicle and remove the support stands.
34. Carefully lower the vehicle onto the flat ground.
35. Torque the lug nuts to 100 ft lbs.
36. Check that all components and fasteners have been properly installed and torqued.
37. Re-read and perform all tasks in the “Before Driving Your Vehicle” section of page 1 of your instructions.

## THANK YOU FOR CHOOSING BELLTECH.

You are now a part of the Belltech family and we are eager to catch a glimpse of your newly modified vehicle. Give us a shout out and let us know how much you love our product. Don't forget, we offer other Belltech related merchandise for you and your vehicle on our website [www.belltech.com](http://www.belltech.com)

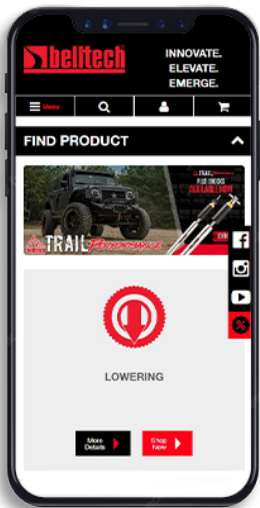

belltechsuspension



Belltech Suspension



@belltechsuspension

If you have any questions, concerns, or warranty related issues regarding your Belltech product, please call or email our experienced customer service specialists.

### Belltech Customer Support:

Phone: 1-800-445-3767

Email: [info@belltech.com](mailto:info@belltech.com)

# KIT CONTENTS



25021		
Part number	Description	Qty
26021-200	BELLTECH LEVELING STRUT	1
25003-015	15MM SPACER	2
25003-075	7.5MM SPACER	1
26021-003	SPRING PERCH	1
65210031	VENT DISK	1
4935-001	15MM PACKER	1
4926-001	BUMP STOP	1
NUT	NYLOC NUT M12 X 1.5	1
25007-777	HARDWARE KIT	1