



300 HUEY LENARD LOOP | WEST MONROE | LA 71292
 OFFICE: 318-397-3000 | FAX: 318-397-3040
 SERVICE & TECH SUPPORT: 800-551-4955
 SUPERLIFT.COM



2019 FORD RANGER 4WD 2 Inch Leveling Kit INSTALLATION INSTRUCTIONS

Engineered for 4WD Models ONLY.
 Fits: 2019 FORD RANGER 4WD



CAUTION: MAKE SURE YOU HAVE THE CORRECT LIFT FOR YOUR VEHICLE:
 Double check the Year, Make, Model, Lift Height and KIT Part Numbers.

NOTE: Prior to beginning the installation, OPEN the Boxes and CHECK the Included Components Compared to the Parts Breakdown. Check all parts and hardware in the box with the parts list below. Be sure you have all needed parts and know where they install.

IF you find a packaging error, contact SUPERLIFT directly. Do not contact the dealer where the system was originally purchased. You will need the control number from each box when calling; this number is located at the bottom of the part number label and to the right of the bar code.

- ① 55-01-40050- Strut Spacers - DR & PA Side
- ② 3/8" Flange Nuts, Coarse Thread, Grade 5
- ③ 10mm Push Nuts
- ④ 3/8" X 1" Carriage Bolts, Coarse Thread, Grade 5



How to Read the Kit Breakdown Charts:

The 'K KIT BREAKDOWN' lists the Part Numbers, Quantities & Part Description of the Boxes that are included in the K KIT. The 'KIT BREAKDOWN' lists Part Numbers, Quantities & Part Description of the Individual Components & Hardware Bags that are included in Each Box. The 'HARDWARE BREAKDOWN' lists the Part Numbers, Quantities & Part Description of the Individual Components.

KIT BREAKDOWN		
Kit Part Number	40050	
Part Number	Qty.	Description
55-01-40050	2	Strut Spacers, 2019+ Ford Ranger
77-40050	1	Hardware Bag

HARDWARE BAG BREAKDOWN		
Kit Part Number	77-40050	
Part Number	Qty.	Part Description
38x1C5CB	6	3/8" X 1" Carriage Bolts, Coarse Thread, Grade 5
10MPN	6	10mm Push Nuts
38C5FN	6	3/8" Flange Nuts, Coarse Thread, Grade 5

THANK YOU FOR CHOOSING SUPERLIFT FOR ALL YOUR SUSPENSION NEEDS!!

INTRODUCTION BEFORE INSTALLATION...

Installation requires a professional mechanic. In addition to these instructions, professional knowledge of disassembly / reassembly procedures and post installation checks must be known.

PRIOR to beginning, inspect the vehicles steering, driveline, and brake systems, paying close attention to the suspension link arms and bushings, sway bars and bushings, tie rod ends, pitman arm, idler arm, ball joints and wheel bearings. Also check the steering sector-to-frame and all suspension-to-frame attaching points for stress cracks. The overall vehicle must be in excellent working condition; repair or replace all worn parts.

Read instructions several times before starting. Read each step completely as you go.

Be sure you have all needed parts and know where they install.

⚠ NOTES:

- Do NOT install this suspension system in conjunction with any other type of aftermarket or fabricated components to gain additional suspension height.
- Do not fabricate any components to gain additional suspension height.
- Prior to attaching components, be sure all mating surfaces are free of grit, grime, grease, undercoating, etc.
- Front end alignment is necessary.
- Tool and Wrench/Socket size is given in brackets [] after each appropriate step.
- A foot-pound torque reading is given in parenthesis () after each appropriate fastener.
- Always wear safety glasses when using power tools.
- A factory service manual should be on hand for reference.
- Due to payload options and initial ride height variances, the amount of lift is a 'base figure'. Final ride height dimensions may vary in accordance to original vehicle stance.

BEFORE YOU DRIVE...

Check all fasteners for proper torque. Check to ensure for adequate clearance between all rotating, mobile, fixed, and heated members. Verify clearance between exhaust and brake lines, fuel lines, fuel tank, floor boards and wiring harness. Check steering components for clearance.

Test and inspect brake system. Perform steering sweep to ensure front brake hoses have adequate slack and do not contact any rotating, mobile or heated members. Inspect rear brake hoses at full extension for adequate slack. Failure to perform hose check/replacement may result in component failure.

Perform head light check and adjustment.

⚠ WARNING: It is ultimately the buyer's responsibility to have all bolts / nuts checked for tightness after the first 100 miles and then every 1000 miles. The steering, suspension and driveline systems, plus wheel alignment should be inspected by a qualified professional mechanic at least every 3000 miles.

TIRES & WHEELS...

Larger rim and tire combinations may increase leverage on suspension, steering, and related components. When selecting combinations larger than OE, consider the additional stress you could be inducing on the OE and related components.

⚠ NOTE: Stock 17" & 18" Wheels WILL Fit back on the vehicle once this suspension system is installed.

TIRE SIZE SPECIFICATIONS			
Tire Size	Wheel	Backspacing (INCH)	Offset (MM)
265/70 R17	Factory	-	-
255/75 R17	Factory	-	-
265/65 R18	Factory	-	-
285/55 R20	20x9	5.00	+30mm

⚠ WARNING: Aftermarket Wheels MUST have a Minimum of 93.1mm Center Bore and Maximum 6.5" Back Spacing. Wheels with Less Than 6.5" of Back Spacing May Require Slight Trimming. ANY larger or wider tire & wheel combination other than listed Will Require Vehicle Trimming.

NOTE: **ALL Tire & Wheel Combinations Should Be Test Fit Prior to Installation. * Some Minor Trimming Maybe Required.** Some minor trimming will be required with certain wheel/tire combinations. This is normal with most aftermarket tire/wheel fitments on GM trucks. Trimming will normally include the bottom edge of the inner fender shrouds and/or lower corner of front bumper valance. As a rule of thumb, deeper backspacing and shorter/narrower tires will reduce/eliminate trimming required.

IMPORTANT DISCLAIMER: The provided tire/wheel fitments are approximate. Actual dimensions of a given tire size can vary considerably from one brand to another. Manufacturers' wheel offset and backspacing measurement points are not always consistent. Backspacing greatly impacts tire-to-fender clearance when turning. Wheel width and backspacing influence whether the tires protrude past the fenders, and to what extent. Considering these important factors, we recommend that you fit-check your tire/wheel selection prior to purchasing. The provided tire/wheel fitments are approximate.

TOOLS & TECH...

The chart is a listing of the main tools need to install this lift kit system.

We have also included a **Tech Tip** noted by this icon  **TECH TIP** to help if we have found a quicker or easier way to accomplish a task in the steps.

Tools			
Miscellaneous Tools	Wrench / Socket Sizes		
Floor Jacks	Standard	Metric	
Jack Stands	9/16"	15mm	22mm
Torque Wrench		18mm	24mm
		19mm	22mm

Torque Specifications					
STANDARD			METRIC		
Size	Grade 5	Grade 8	Size	Grade 8.8	Grade 10.9
5/16"	15 ft/lbs.	20 ft/lbs.	6mm	5 ft/lbs.	9 ft/lbs.
3/8"	30 ft/lbs.	35 ft/lbs.	8mm	18 ft/lbs.	23 ft/lbs.
7/16"	45 ft/lbs.	60 ft/lbs.	10mm	32 ft/lbs.	45 ft/lbs.
1/2"	65 ft/lbs.	90 ft/lbs.	12mm	55 ft/lbs.	75 ft/lbs.
9/16"	95 ft/lbs.	130 ft/lbs.	14mm	85 ft/lbs.	12 ft/lbs.
5/8"	135 ft/lbs.	175 ft/lbs.	16mm	130 ft/lbs.	165 ft/lbs.
3/4"	185 ft/lbs.	280 ft/lbs.	18mm	170 ft/lbs.	240 ft/lbs.

NOTE: Use the check-off box found at each step to help you keep your place. Two denotes that one check-off box is for the Driver Side (Left) and one is for the Passenger Side (Right). Unless otherwise noted, always start with the Driver Side.

FRONT DISASSEMBLY

NOTE: Save all factory components and hardware for reuse, unless noted.

1) PREPARE VEHICLE...

Chock rear tires and place transmission in neutral. Raise front of vehicle with a jack and secure a jack stand beneath each frame rail behind the lower control arms. Ease the frame down onto the stands and place transmission in park. Chock the rear tires.

Remove front tires and wheels. [Lug Nuts 19mm]

NOTE: **Perform Steps 2-6 One Side At A Time. Start on the Driver Side & Complete Steps 2-6. THEN Go to the Passenger Side & Complete Steps 2-6.**

2) DISCONNECT SWAY BAR LINK...

[Illustration 1] Disconnect sway bar end link from knuckle. [18mm]

3) LOOSEN UPPER BALL JOINT...

[Illustration 2] Loosen the upper control arm ball joint from the knuckle, but Do NOT Remove. [18mm]

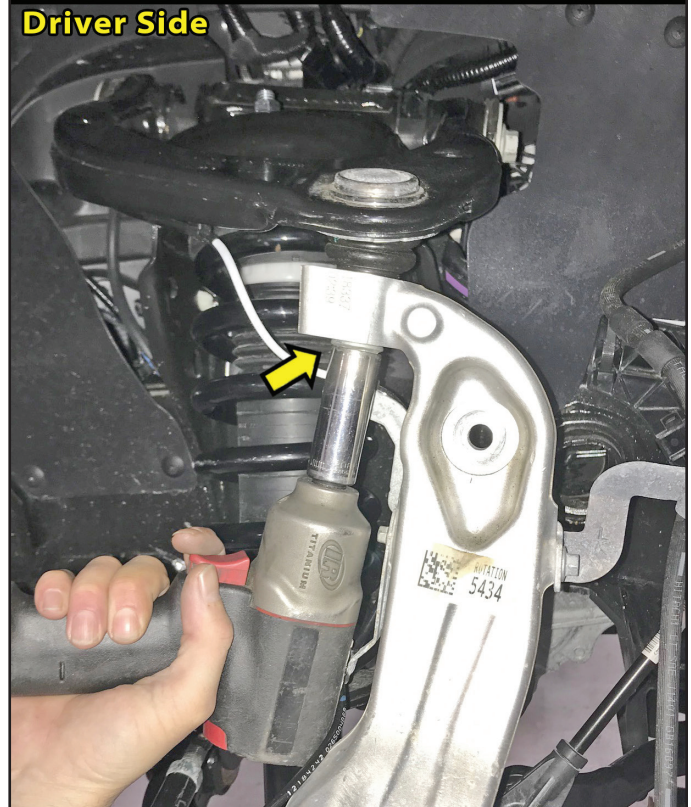
Illustration 1**Disconnect Sway Bar Link from Knuckle...****Driver Side****Illustration 2****Loosen Upper Ball Joint from Knuckle...****Driver Side****4) LOOSEN UPPER STRUT MOUNTS...**

[Illustration 3] Remove two (2) of the upper strut nuts and loosen the third (3rd), but leave this nut attached to hold the strut in place. [15mm]

5) DISCONNECT LOWER STRUT MOUNT...

[Illustration 4] Remove the two (2) nuts holding the strut to the lower control arm. [18mm]

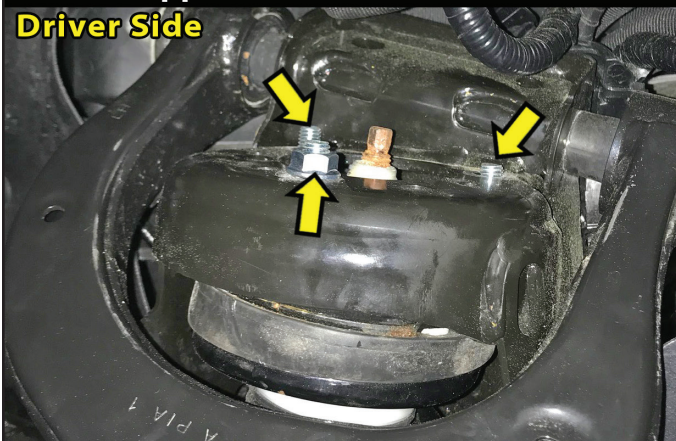
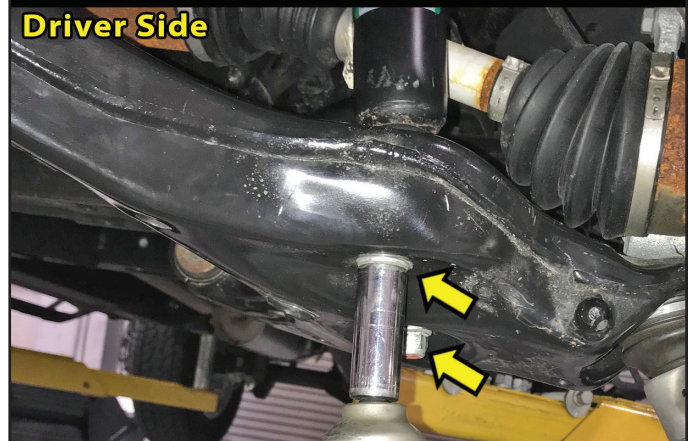
Illustration 3**Loosen Upper Strut Mount...****Driver Side****Illustration 4****Disconect Lower Strut Mount...****Driver Side**

6) STRUT REMOVAL...

- [Illustration 5-A] Mark the position of the alignment cams attaching the lower control arm to the frame.
- [Illustration 5-B] Remove the lower control arm bolts from the frame. [24mm & 22mm]
- [Illustration 5-C] Lower the control arm down far enough to remove the strut.
- [Illustration 5-D] Remove the still attached nut from the upper strut mount. Remove the strut from the vehicle.

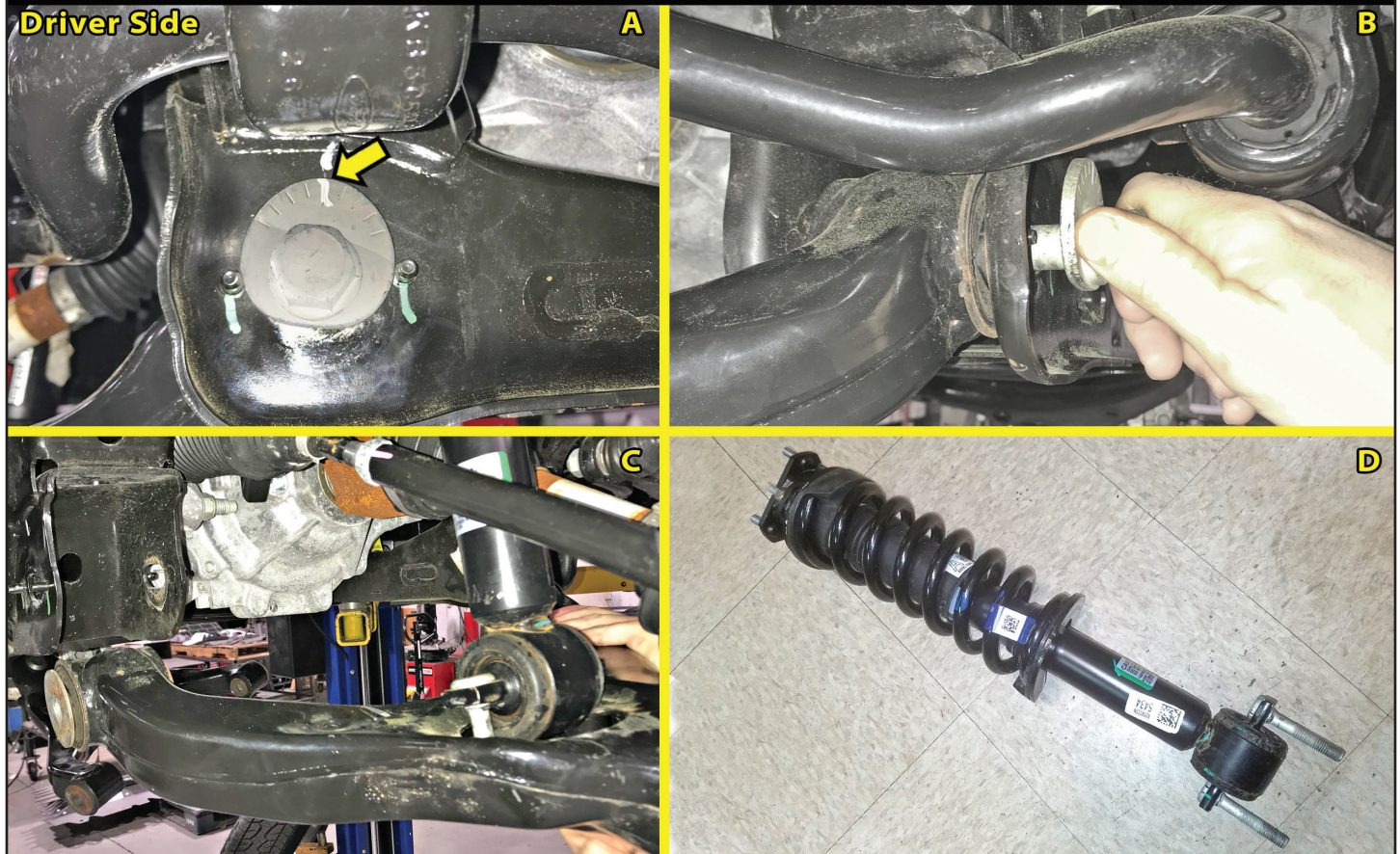
Illustration 5**Mark & Remove Lower Control Arm Bolts, Lower the Control Arm & Remove Strut...**

⚠ NOTE: Repeat steps 2 through 6 on the Passenger Side.

7) ASSEMBLE AND INSTALL STRUT SPACERS...

Locate the (2) SUPERLIFT strut spacers (#55-01-40050) - for Driver & Passenger. Strut Spacers Are NOT Side Specific. Locate Hardware Bag #77-40050. Hardware PER Side: (3) 3/8" X 1" Carriage Bolts, Coarse Thread, Grade 5, (3) 10mm Push Nuts & (3) 3/8" Flange Nuts, Coarse Thread, Grade 5.

- [Illustration 6-A] Using a cutoff wheel or similar tool, trim the (3) OE Strut studs down to the top most thread.
- [Illustration 6-B] Insert 3/8" X 1" carriage bolts into the top of the strut spacer (#55-01-40050). Slide push nut onto the carriage bolts to hold bolts in place for installation.
- [Illustration 6-C & 6-D] Attach the strut spacer assembly onto the top of the strut by aligning the strut spacer assembly onto the factory strut dowel pin and three (3) factory studs. Secure using the OE hardware. [15mm] (40)

Illustration 6

Assemble & Install Strut Spacers...

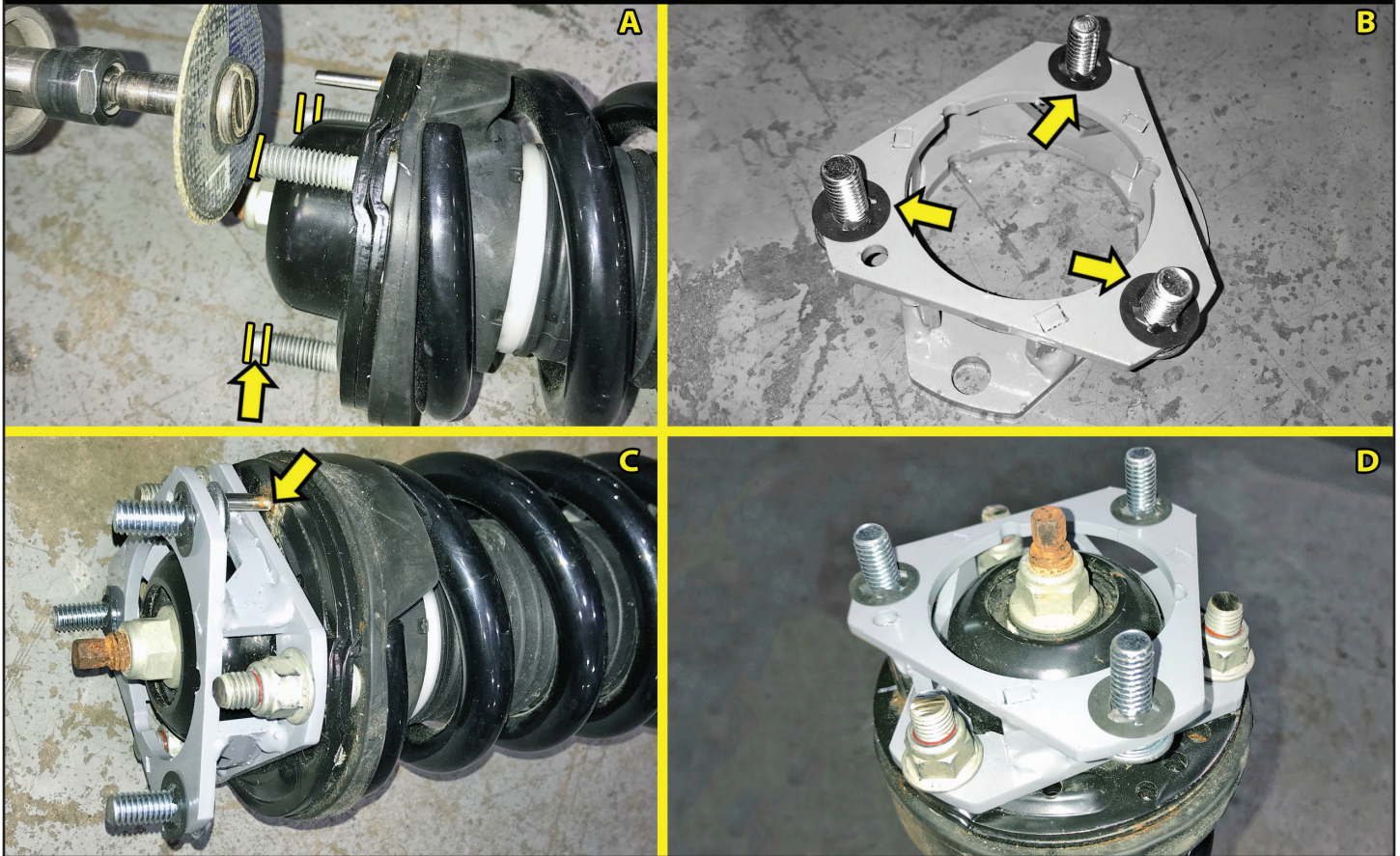

⚠ NOTE: Perform Steps 8-10 One Side At A Time. Start on the Driver Side & Complete Steps 8-10. THEN Go to the Passenger Side & Complete Steps 8-10.

8) INSTALL STRUT ASSEMBLY...

- [Illustration 7-A] Reinstall the strut assembly onto the vehicle and loosely attach to the strut tower using the 3/8 flange nuts provided. [9/16]
- [Illustration 7-B] Raise the lower control arm into position being sure to insert the lower strut studs into the arm. Secure the strut to the lower control arm using the OE hardware. [18mm]
- [Illustration 7-C] Tighten the three (3) upper strut bolts. [9/16]
- [Illustration 7-D] Secure the lower control arm to the frame using the OE hardware. Do not fully tighten at this time. [24mm & 21mm] **⚠ NOTE:** Re-align the alignment cams to the marks you made.

Illustration 7

Install Strut Assembly...

Driver Side

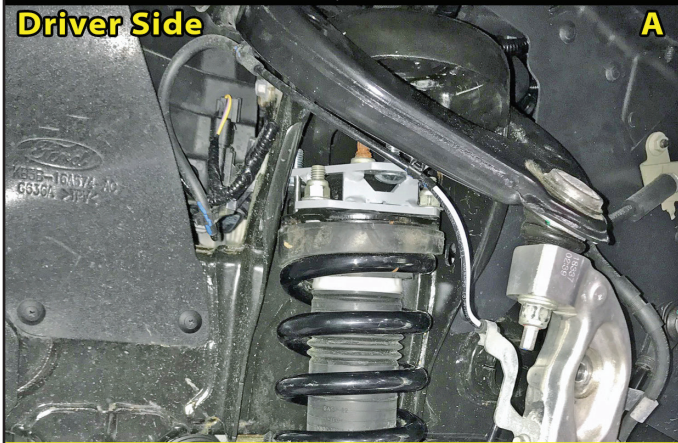

A



B



C

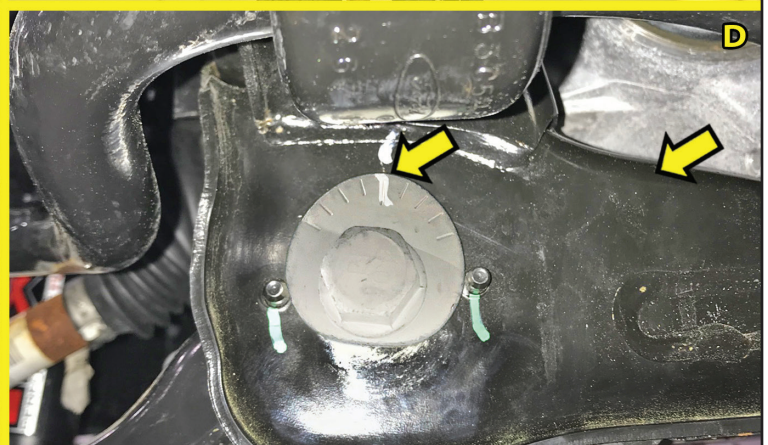

D

9) UPPER BALL JOINT...

[Illustration 8] Tighten the upper ball joint. [18mm]

10) SWAY BAR LINK...

[Illustration 9] Reattach the sway bar link to the knuckle. [18mm]

Illustration 8

Tighten Upper Ball Joint to Knuckle...

Driver Side

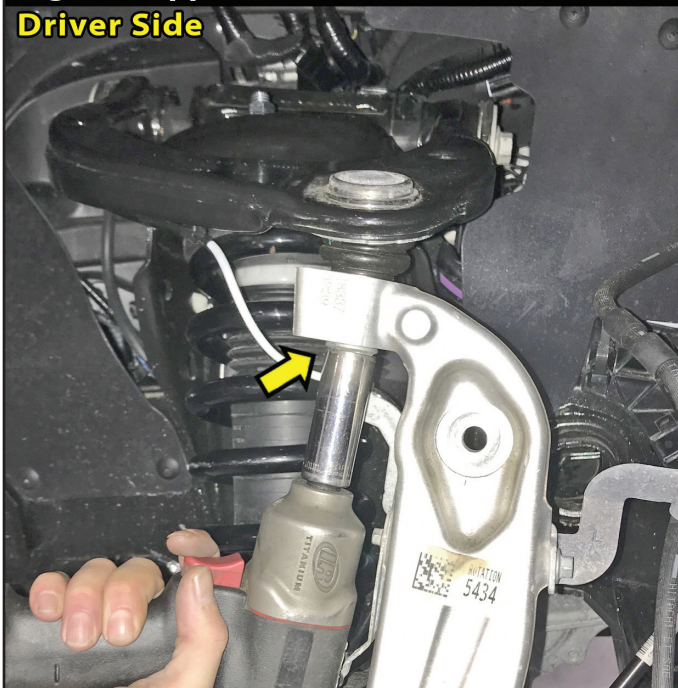
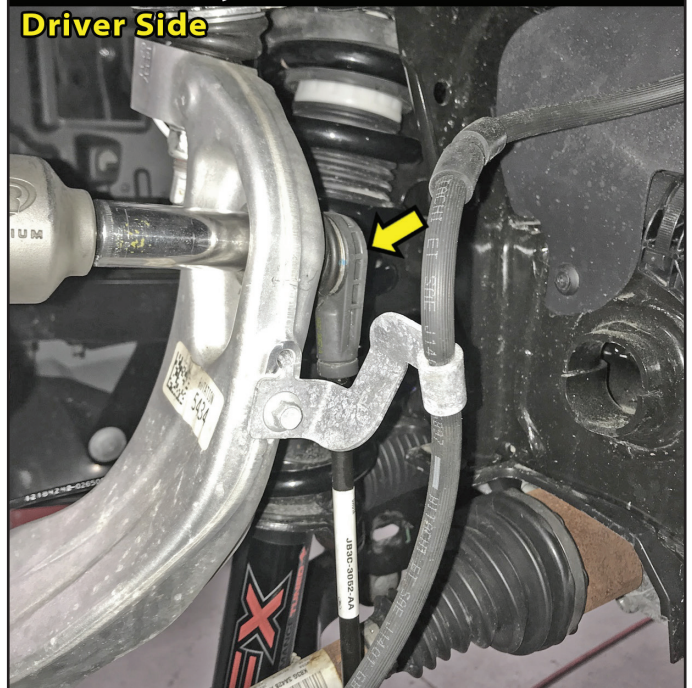

Illustration 9

Connect Sway Bar Link to Knuckle...

Driver Side



NOTE: Repeat steps 8 through 10 on the Passenger Side.

11) TIRES / WHEELS...

[Illustration 10] Reinstall tires and wheels. Tighten the lug nuts in the sequence shown. (151) [22mm]

WARNING: When the tires / wheels are installed, always check for and remove any corrosion, dirt, or foreign material on the wheel mounting surface, or anything that contacts the wheel mounting surface (hub, rotor, etc.). Installing wheels without the proper metal-to-metal contact at the wheel mounting surfaces can cause the lug nuts to loosen and the wheel to come off while the vehicle is in motion.

WARNING: Retighten lug nuts at 500 miles after any wheel change, or anytime the lug nuts are loosened. Failure to do so could cause wheels to come off while vehicle is in motion.

Lower vehicle to the floor.

FINAL CHECKS

12) CLEARANCE CHECK...

Check all hardware for proper torque specifications.

With the vehicle on the ground, check all components for proper operation and clearances. Pay special attention to the clearance between the tires / wheels, brake hoses, wiring, etc. Check tire/wheel clearance with the fenders/bumper as well as with the steering knuckle.

13) WHEEL ALIGNMENT...

Realign vehicle to factory OEM specifications. It is necessary to have a proper and professional wheel alignment performed by a certified alignment technician. Align the vehicle to factory specifications. It is recommended that your vehicle alignment be checked after any off-road driving.

14) HEADLIGHTS...

Re-adjust headlights to proper setting. In addition to your vehicle alignment, for your safety and others, it is necessary to check and adjust your vehicle head lamps for proper aim and alignment.

15) FOUR WHEEL DRIVE...

Activate four wheel drive system and check for proper engagement.

16) SUPERLIFT WARNING DECAL...

Install the **Warning to Driver** decal on the inside of the windshield or dash within the Driver's view.

IMPORTANT MAINTENANCE INFORMATION

WARNING: It is the ultimate buyer's responsibility to have all bolts / nuts checked for tightness after the first 100 miles and then every 1000 miles. The steering, suspension and driveline systems, plus wheel alignment should be inspected by a qualified professional mechanic at least every 3000 miles.

LIMITED LIFETIME WARRANTY / WARNINGS

Your SUPERLIFT® product is covered by the Limited Warranty explained below that gives you specific legal rights. This limited warranty is the only warranty SUPERLIFT® makes in connection with your product purchase. SUPERLIFT® neither assumes nor authorizes any retailer or other person or entity to assume for it any other obligation or liability in connection with this product or limited warranty.

[Illustration 10

Lug Nut Torque Sequence...

Follow the Sequence Below to Torque the Lug Nuts

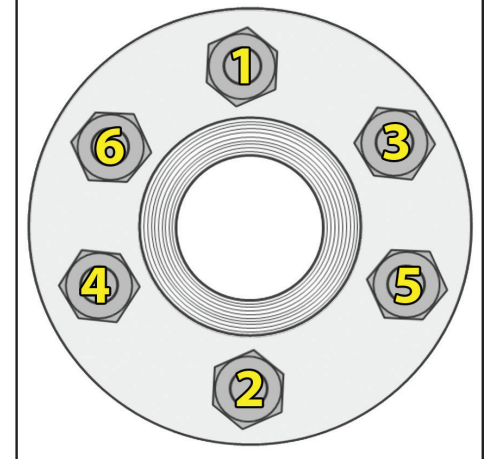

SUPERLIFT, LLC, LIMITED LIFETIME WARRANTY

What is covered? Subject to the terms below, SUPERLIFT® will repair or replace its products found defective in materials or workmanship for so long as the original purchaser owns the vehicle on which the product was originally installed. Your warranter is SUPERLIFT, LLC, doing business as SUPERLIFT® Suspension Systems ("SUPERLIFT®").

What is not covered? Your SUPERLIFT® Limited Warranty does not cover products SUPERLIFT® determines to have been damaged by or subjected to:

- Alteration, modification or failure to maintain.
- Normal wear and tear (bushings, rod ends, etc.). Scratches or defects in product finishes (powder coating, plating, etc.).
- Damage to, or resulting from, the vehicle's electronic stability system, related components or other vehicle systems.
- Racing or other vehicle competitions or contests. Accidents, impact by rocks, trees, obstacles or other aspects of the environment.
- Theft, vandalism or other intentional damage.

Remedy Limited to Repair or Replacement. The exclusive remedy provided hereunder shall, upon SUPERLIFT's inspection and at SUPERLIFT's option, be either repair or replacement of the product covered under this Limited Warranty. Customers requesting warranty consideration should contact SUPERLIFT® by phone (1-800-551-4955) to obtain a Returned Goods Authorization number. All removal, shipping and installation costs are customer's responsibility.

If a replacement part is needed before the SUPERLIFT® part in question can be returned, you must first purchase the replacement part. Then, if the part in question is deemed warrant-able, you will be credited / refunded.

OTHER LIMITATIONS - EXCLUSION OF DAMAGES - YOUR RIGHTS UNDER STATE LAW

- Neither SUPERLIFT® nor your independent SUPERLIFT® dealer are responsible for any time loss, rental costs, or for any incidental, consequential or other damages you may have.
- This Limited Warranty gives you specific rights, and this is the only warranty SUPERLIFT® makes in connection with your product purchase. You may also have other rights that vary from state to state. For example, while all implied warranties are disclaimed herein, any implied warranty required by law is limited to the terms of our Limited Lifetime Warranty as described above. Some states do not allow limitations of how long an implied warranty lasts and / or do not allow the exclusion or limitation of incidental or consequential damages, so the limitations and exclusions herein may not apply to you. SUPERLIFT® neither assumes nor authorizes any retailer or other person or entity to assume for it any other obligation or liability in connection with this product or Limited Warranty.

IMPORTANT PRODUCT USE AND SAFETY INFORMATION / WARNINGS

⚠️WARNING: As a general rule, the taller a vehicle is, the easier it will roll over. Offset, as much as possible, what is lost in rollover resistance by increasing tire track width. In other words, go "wide" as you go "tall"; always use as wide a tire and wheel combination as feasible to enhance vehicle stability. We strongly recommend, because of rollover possibility, that the vehicle be equipped with a functional roll bar and cage system. Seat belts and shoulder harnesses should be worn at all times. Avoid situations where a side rollover may occur.

Generally, braking performance and capabilities are decreased when significantly larger / heavier tires and wheels are used. Take this into consideration while driving. Also, changing axle gear ratios or using tires that are taller or shorter than factory height will cause an erroneous speedometer reading. On vehicles equipped with an electronic speedometer, the speed signal impacts other important functions as well. Speedometer recalibration for both mechanical and electronic types is highly recommended.

Do not add, alter, or fabricate any factory or aftermarket parts to increase vehicle height over the intended height of the SUPERLIFT® product purchased. Mixing component brands is not recommended.

WE WANT TO SEE YOUR RIDE...

Grab photos of your SUPERLIFT Equipped truck in various poses and in action.

Email pictures to us at sales@superlift.com

Tag us on **Facebook:** @superlift suspension systems

Tag us on **Instagram:** #superlift, #superliftsuspension, #superliftequipped

THANKS For Choosing SUPERLIFT...

For questions, technical support and warranty issues relating to this SUPERLIFT products, please contact SUPERLIFT directly.

**SUPERLIFT SUSPENSION
300 Huey Lenard Loop Rd.
West Monroe, Louisiana 71292
Phone: (318) 397-3000
Sales / Tech: (800) 551-4955
Fax: (318) 397-3040
SUPERLIFT.COM**