

INSTALLATION GUIDE

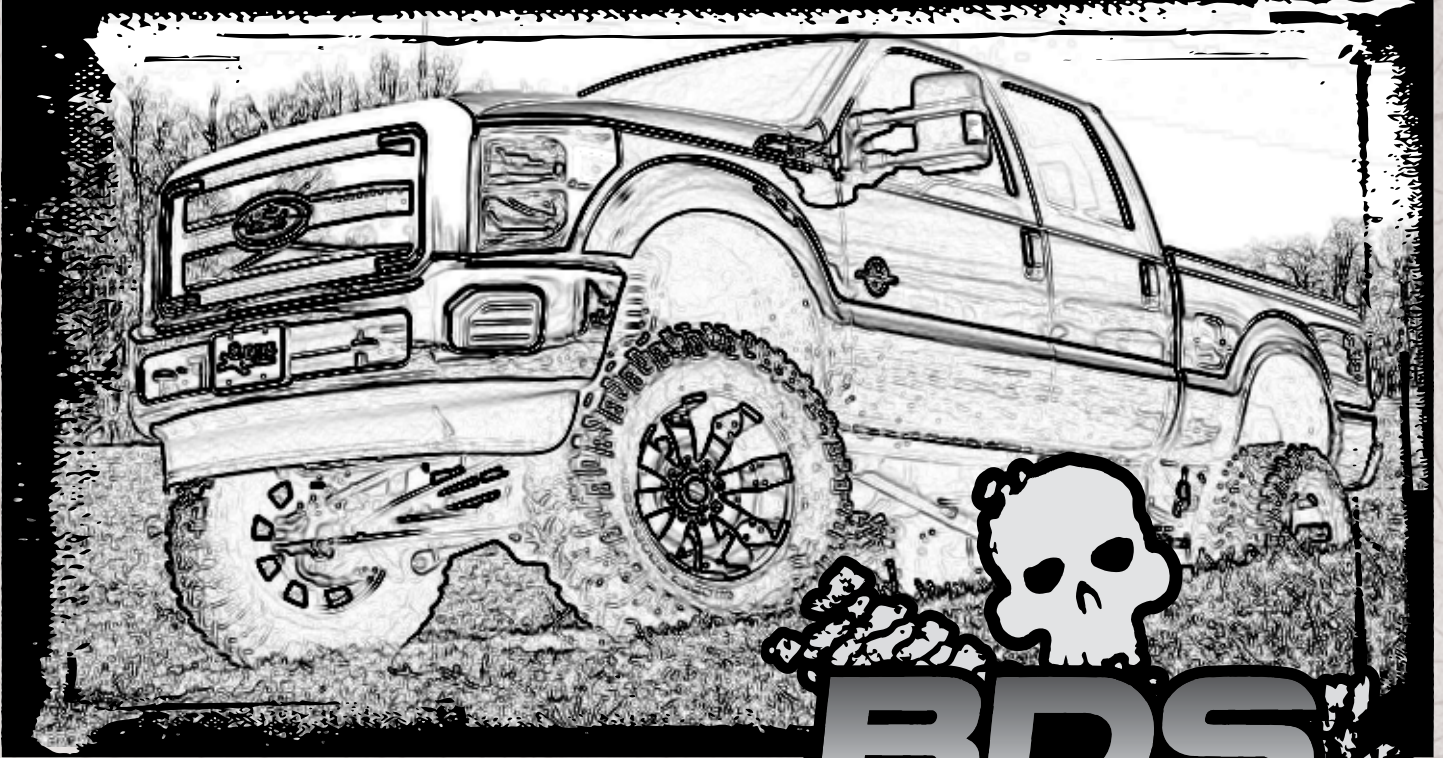

Part#: 123612



HARDCORE LIMITED LIFETIME WARRANTY

Superduty Coilover Conversion

Ford F-150/ F-350 Superduty 4WD | 2005-2016

Rev. 011018

491 W. Garfield Ave., Coldwater, MI 49036 • Phone: 517-279-2135

Web: www.bds-suspension.com • E-mail: tech-bds@sporttruckusainc.com

Read And Understand All Instructions And Warnings Prior To Installation Of System And Operation Of Vehicle.



THANK YOU

Your truck is about to be fitted with the best suspension system on the market today. That means you will be driving the baddest looking truck in the neighborhood, and you'll have the warranty to ensure that it stays that way for years to come.

Thank you for choosing BDS Suspension!

BEFORE YOU START

BDS Suspension Co. recommends this system be installed by a professional technician. In addition to these instructions, professional knowledge of disassembly/ reassembly procedures and post installation checks must be known.

FOR YOUR SAFETY

Certain BDS Suspension products are intended to improve off-road performance. Modifying your vehicle for off-road use may result in the vehicle handling differently than a factory equipped vehicle. Extreme care must be used to prevent loss of control or vehicle rollover. Failure to drive your modified vehicle safely may result in serious injury or death. BDS Suspension Co. does not recommend the combined use of suspension lifts, body lifts, or other lifting devices. You should never operate your modified vehicle under the influence of alcohol or drugs. Always drive your modified vehicle at reduced speeds to ensure your ability to control your vehicle under all driving conditions. Always wear your seat belt.

BEFORE INSTALLATION

- Special literature required: OE Service Manual for model/year of vehicle. Refer to manual for proper disassembly/reassembly procedures of OE and related components.
- Adhere to recommendations when replacement fasteners, retainers and keepers are called out in the OE manual.
- Larger rim and tire combinations may increase leverage on suspension, steering, and related components. When selecting combinations larger than OE, consider the additional stress you could be inducing on the OE and related components.
- Post suspension system vehicles may experience drive line vibrations. Angles may require tuning, slider on shaft may require replacement, shafts may need to be lengthened or trued, and U-joints may need to be replaced.
- Secure and properly block vehicle prior to installation of BDS Suspension components. Always wear safety glasses when using power tools.
- If installation is to be performed without a hoist, BDS Suspension Co. recommends rear alterations first.
- Due to payload options and initial ride height variances, the amount of lift is a base figure. Final ride height dimensions may vary in accordance to original vehicle attitude. Always measure the attitude prior to beginning installation.



Visit 560plus.com for more information.

TIRES AND WHEELS

See Lift Kit Specifications



BEFORE YOU DRIVE

Check all fasteners for proper torque. Check to ensure for adequate clearance between all rotating, mobile, fixed, and heated members. Verify clearance between exhaust and brake lines, fuel lines, fuel tank, floor boards and wiring harness. Check steering gear for clearance. Test and inspect brake system.

Perform steering sweep to ensure front brake hoses have adequate slack and do not contact any rotating, mobile or heated members. Inspect rear brake hoses at full extension for adequate slack. Failure to perform hose check/ replacement may result in component failure. Longer replacement hoses, if needed can be purchased from a local parts supplier.

Perform head light check and adjustment.

Re-torque all fasteners after 500 miles. Always inspect fasteners and components during routine servicing.

CONTENTS OF YOUR KIT

Box Kit 123612

Part #	Qty	Description
02714	1	05+ Ford Superduty Coilover Conversion Upper Brkt - DRV
02715	1	05+ Ford Superduty Coilover Conversion Upper Brkt - PASS
02716	2	05+ Ford Superduty Coilover Conversion - lower bracket
02856	2	Upper Reservoir Mounting Bracket
952	1	Bolt Pack - Mounting Brackets
953	1	Bolt Pack - Lower Hardware
	1	loc-tite
54314	2	5/8" x 1/2" ID x 1.47" Sleeve
54587	2	3/4" x 9/16" x 1.575" Sleeve
SB33BK	2	5/8" ID bushing - Upper
SB35BK	2	3/4" ID bushing - Lower
02906	2	Bump Stop Spacer Plate

Bolt Pack # 952

Part #	Qty	Description
	2	1/2"-13 x 6" Bolt - Grade 8 - Yellow Zinc
	2	1/2"-13 x 5" Bolt - Grade 8 - Yellow Zinc
	2	1/2"-13 x 3" Bolt - Grade 8 - Yellow Zinc
	14	1/2"-13 x 1-1/2" Bolt - Grade 8 - Yellow Zinc
	4	1/2"-13 x 5/8" Bolt - Grade 5 - Clear Zinc
	18	1/2"-13 Prevailing Torque Nut
	38	1/2" SAE Thru-Hardened Washer - Yellow Zinc
	4	1/2" SAE Washer - Clear Zinc

Bolt Pack # 953

Part #	Qty	Description
	2	14mm-2.00 x 30mm Bolt - Class 10.9 - Clear Zinc
	2	14mm Flat Washer - Clear Zinc
	2	7/16" Clamp w/ 0.281 Hole (Fastenal # 0708762)
	4	1/4"-20 x 3/4" Bolt - Grade 5 - Clear Zinc
	4	1/4"-20 Nylock Nut - Clear Zinc
	8	1/4" SAE Washer - Clear Zinc
	4	#10-24 x 3/4" #2 Drive Pan Head Phillips Machine Screw - Clear Zinc
	4	#10-24 Serrated Edge Flanged Nut - Clear Zinc
	4	#10 SAE Washer - Clear Zinc

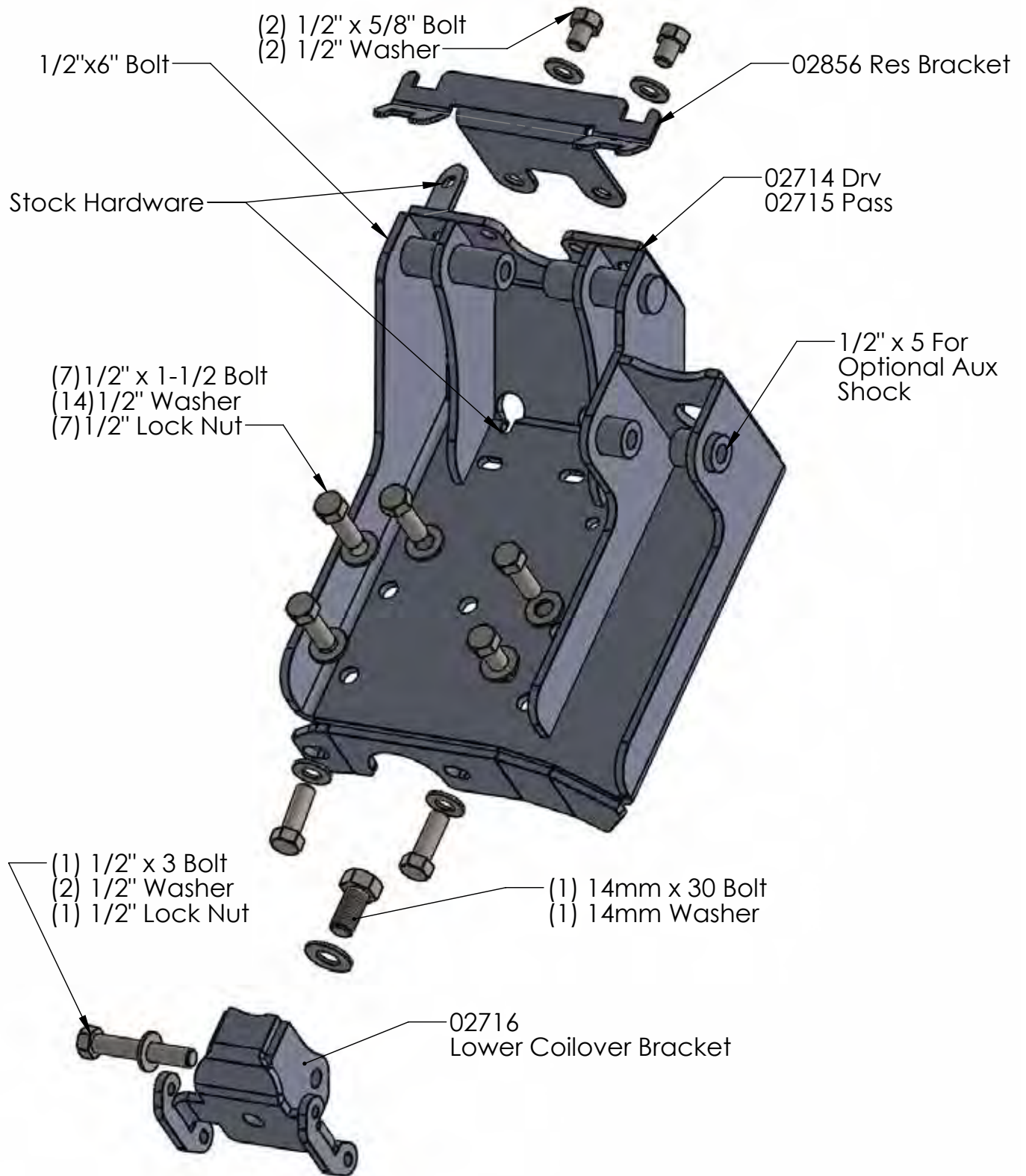

TROUBLESHOOTING INFORMATION FOR YOUR VEHICLE

1. Coilover mounting brackets are designed to replace the factory coil buckets and lower coil seat. Use care to not damage the frame or any electronic modules when performing the installation.

INSTALLATION INSTRUCTIONS

INSTALLATION INSTRUCTIONS

1. Park vehicle on clean, flat, and level surface. Block the rear wheels for safety.
2. Raise the front of the vehicle and support the frame rails with jackstands. Do not support the front of the vehicle on any suspension components.
3. Support the front axle with a hydraulic jack. Remove the front wheels.
4. Disconnect the modules on the side of the frame rail before beginning the installation. Vibration from an air hammer may damage the modules and are expensive to replace. Modules may not be present on earlier year / gas engine configuration trucks. Reattach at the end of the installation. (Fig 1a, 1b)

SPECIAL TOOLS

Drill, Grinder, & General Tools

FIG 1A



FIG 1B



5. Remove the front shocks from the vehicle, disconnect the ABS wire and brake line from the lower axle. (Fig 2)

FIG 2



6. Remove the coils from the vehicle.
7. Remove the factory lower coil perch, the hardware will not be reused.
8. Install the new lower bracket with 14mm hardware with loc-tite. Tighten bolt to 95 ft-lbs. (Fig 3)

FIG 3

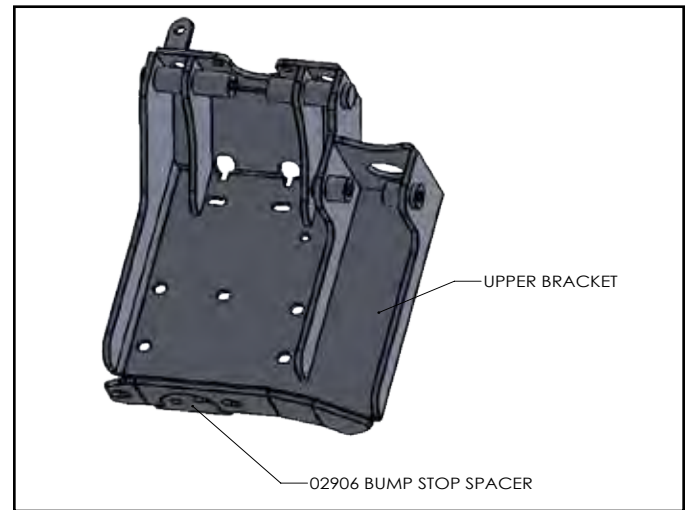

9. On the driver's side only, disconnect the ABS module above the coil bucket. Retain all of the hardware. Raise the module slightly so it is not contacting the coil bucket.
10. Remove the factory bump stops / bump stop brackets. Retain hardware.
11. Remove the 7 rivets that attach the coil bucket to the frame rails. Many methods can be used to remove the rivets. Remove the seven rivets with a grinder, or drill, or combination of these tools. Do not use a torch or air chisel. The undercoating used on the frame is highly flammable. Vibrations from air chisels may damage electronic modules.
12. Install the new coilover mounting bracket with $\frac{1}{2}$ " x 1-1/2" hardware (BP #952). Tighten to 65 ft-lbs. (Fig 4a, 4b) Install the bump stop spacer plate and install bumpstop brackets / bumpstops to the bottom side of the coilover bracket. These are included with the rest of the lift kit. Bump stops must be installed in conjunction with the kit.

FIG 4A**FIG 4B**

13. Reattach the ABS module with factory hardware to the driver's side coilover bracket.
14. Raise or lower the axle to attach the coilover to both brackets. Attach the upper mount with $\frac{1}{2}$ " x 6" bolt with loc-tite, and lower with $\frac{1}{2}$ " x 3" hardware. The reservoir hose will go out towards the front of the vehicle. Tighten the hardware to 65ft-lbs.
15. Attach the reservoir bracket to the coilover bracket with $\frac{1}{2}$ " x 5/8" hardware. Use loc-tite on threads.
16. Attach the reservoir to the bracket with the included hoseclamps.
17. If an auxiliary shock is going to be installed, use the included 1-1/2" wide upper mount bushing / sleeve combination with $\frac{1}{2}$ " x 5" hardware. Tighten to 65 ft-lbs. Attach the lower mount with factory hardware with wider bushing / sleeve setup.
18. Attach the ABS wire to the rear of the new lower coilover mount with #10 hardware (#953).
19. Attach the brake line bracket to the front side of the lower coilover mount. The stock brake line will use the factory bracket with $\frac{1}{4}$ " hardware (#953). Aftermarket brake lines may require part of the factory brake line bracket as shown. Attach with included clamp with $\frac{1}{4}$ " hardware, other variations may be required. Ensure there is adequate slack in the brake line at full droop and full steering sweep. Check again later in the installation at ride height, repeat full steering sweep. (Fig 5)

FIG 5

20. Reinstall wheels. Tighten lug nuts to factory specification. Lower vehicle to the ground.
21. Reattach modules to the side of the frame rails with factory hardware.
22. Recheck all hardware for proper torque. Recheck again after 500 miles.



WE WANT TO SEE YOUR RIDE!

Grab photos of your BDS-equipped truck in action and send them in for a chance to be featured. Send it in to our Bad Ass Rides customer gallery at bds-suspension.com/bar and post them on the BDS Fan Page on Facebook at facebook.com/BDSSuspensions. Don't forget about your BDS swag! BDS offers t-shirts, hoodies, decals and more available on the BDS website or through your local BDS distributor.

TIME TO HAVE SOME FUN

Thank you for choosing BDS Suspension.

For questions, technical support and warranty issues relating to this BDS Suspension product, please contact your distributor/installer before contacting BDS Suspension directly.