

## CAN-AM 2016-21 Defender Forward Offset Control Arms

**Thank you for choosing Rough Country for all your vehicle needs.**

Please read instructions before beginning installation. Check the kit hardware against the kit contents shown below. Be sure you have all needed parts and know where they go.

If question exist, please call us @1-800-222-7023. We will be happy to answer any questions concerning this product.

Check all fasteners for proper torque. Check to ensure for adequate clearance between all components.

Periodically check all hardware for tightness.

### KIT CONTENTS:

- Dr Upper Control Arm x1
- Pass Upper Control Arm x1
- Dr Lower Control Arm x1
- Pass Lower Control Arm x1
- Control arm Bushing x16
- Control arm Sleeve x8
- Grease Fittings x8

### TOOLS NEEDED:

- 15mm Socket/Wrench
- 19mm Socket/Wrench



### Torque Specs:

Size	Grade 5	Grade 8	Size	Class 8.8	Class 10.9
5/16"	15 ft/lbs	20ft/lbs	6MM	5ft/lbs	9ft/lbs
3/8"	30 ft/lbs	35ft/lbs	8MM	18ft/lbs	23ft/lbs
7/16"	45 ft/lbs	60ft/lbs	10MM	32ft/lbs	45ft/lbs
1/2"	65 ft/lbs	90ft/lbs	12MM	55ft/lbs	75ft/lbs
9/16"	95 ft/lbs	130ft/lbs	14MM	85ft/lbs	120ft/lbs
5/8"	135ft/lbs	175ft/lbs	16MM	130ft/lbs	165ft/lbs
3/4"	185ft/lbs	280ft/lbs	18MM	170ft/lbs	240ft/lbs



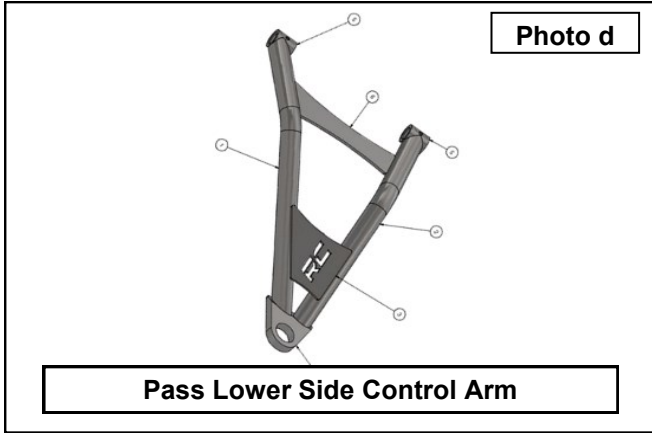
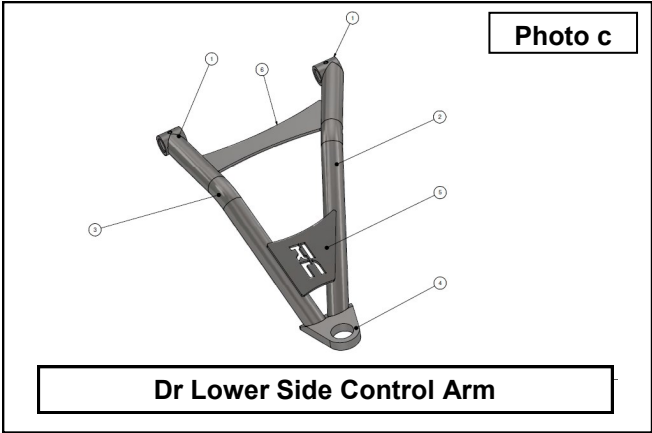
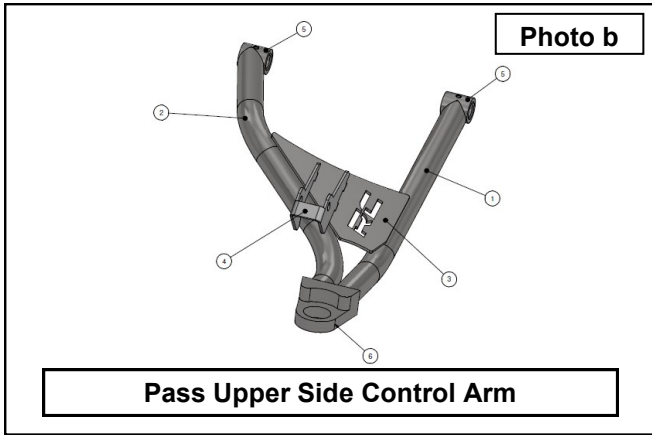
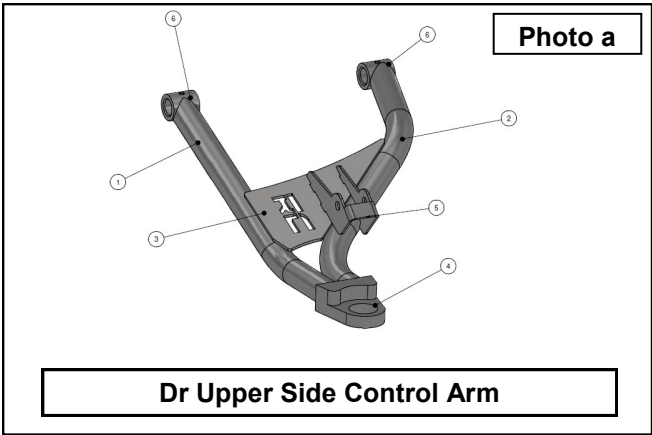

## INSTALLATION INSTRUCTIONS

1. Jack up the front of the vehicle and place on jack stands. Remove the front wheels.
2. Remove the bolt from knuckle at the control arms using a 19mm socket/wrench. **See Photo 1.**
3. Remove the lower strut bolt from the upper control arm using two 15mm socket/wrenches. **See Photo 2.**

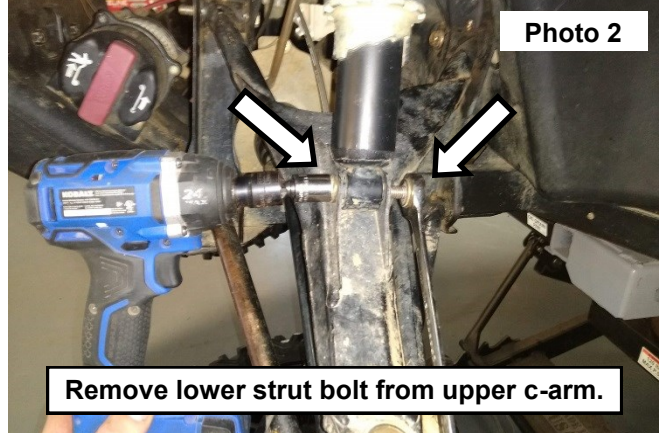
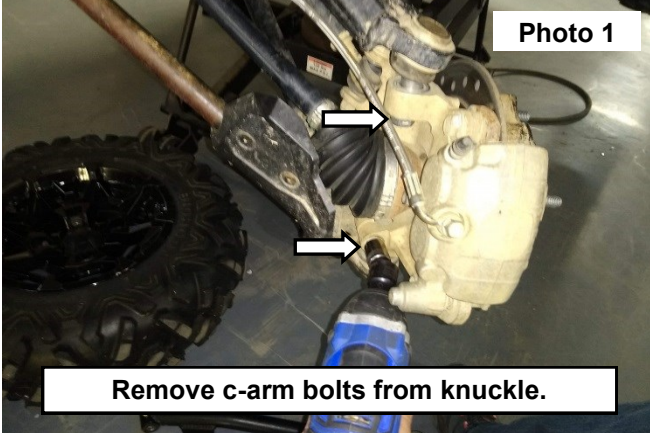

4. Remove the control arms from the frame using two 15mm socket/wrenches. **See Photo 3 and Photo 4.**

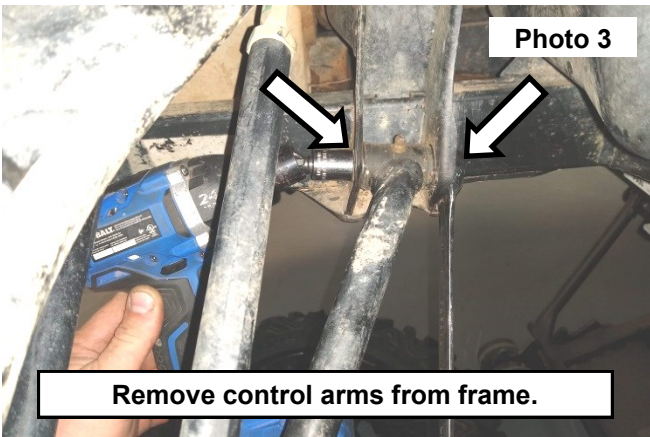

5. Install the bushings, sleeves, and grease fittings in each control arm eyelet and ball joint.
6. Install the lower control arm (Photos c or d from page 2) to the frame using the stock hardware. **See Photo 5.**
7. Install the upper control arm (Photos a or b from page 2) to the frame using the stock hardware. **See Photo 6.**

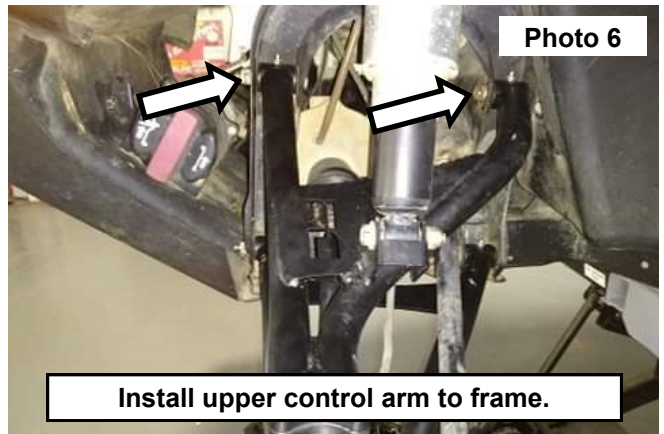
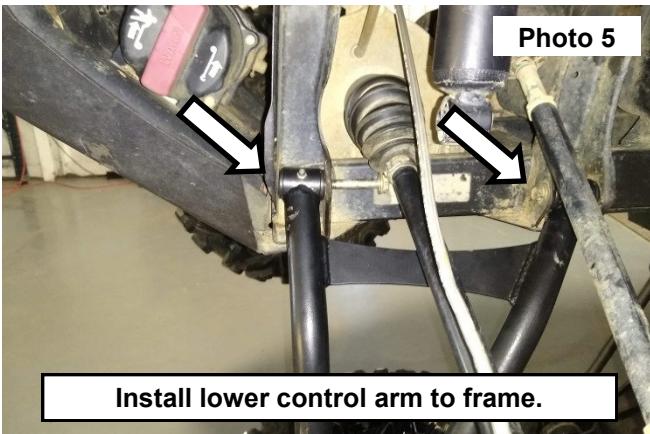



8. Install the lower and upper control arms to the knuckle using the stock hardware. See Photo 7 and Photo 8.

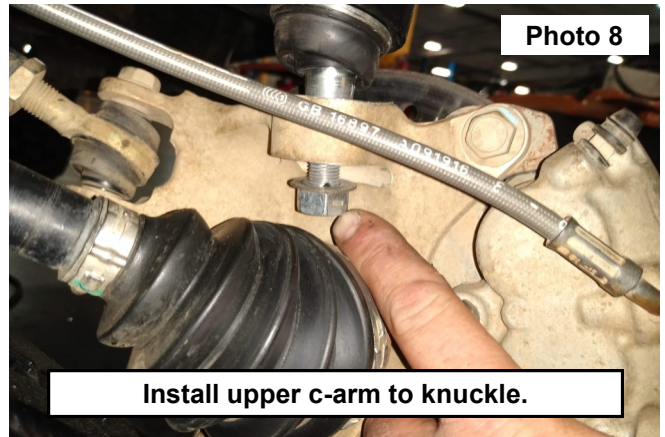
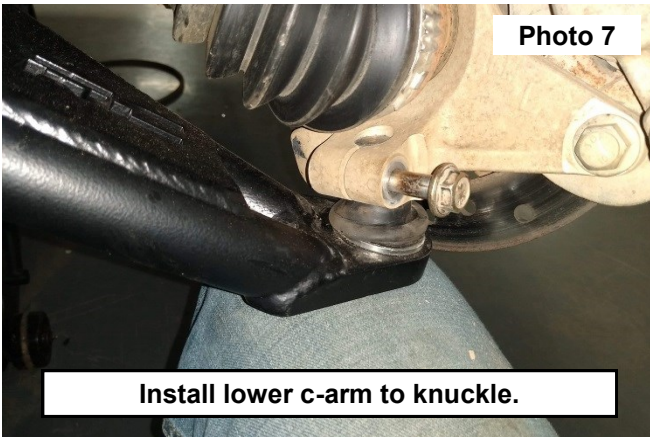

9. **NOTICE** Grease ball joints and control arm eyelets before use.

10. Put on wheels and lower.



By purchasing any item sold by Rough Country, LLC, the buyer expressly warrants that he/she is in compliance with all applicable, State, and Local laws and regulations regarding the purchase, ownership, and use of the item. It shall be the buyers responsibility to comply with all Federal, State and Local laws governing the sales of any items listed, illustrated or sold. The buyer expressly agrees to indemnify and hold harmless Rough Country, LLC for all claims resulting directly or indirectly from the purchase, ownership, or use of the items.

