

AIR LIFT
PERFORMANCE

INSTALLATION GUIDE



Kit 78105

Acura TLX

FRONT APPLICATION

For maximum effectiveness and safety, please read these instructions completely before proceeding with installation.

Failure to read these instructions can result in an incorrect installation which could result in damage to the vehicle, minor to severe personal injury or death.

Protect your Air Lift Performance Purchase by Completing your Warranty Registration



Thank you for purchasing an Air Lift Performance product!

Take a photo of your sales receipt and then scan the
QR code to complete your online warranty registration.

TABLE OF CONTENTS

P.02

Introduction

Notation Explanation

P.03

System Overview

P.04

Installing the System

Important Safety Notices

Section 1. Remove the Suspension

Section 2. Install the Air Suspension

Section 3. Route the Air Lines

After Initial Installation of Sleeve-Style Dampers

P.14

Finished Installation

P.15

Before Operating

Set the Ride Height

Torque Specifications

Suggested Driving Air Pressure

Maximum Air Pressure

Check for Binding

Installation Checklist

Damping Adjustment

P.17

Limited Warranty and Return Policy

Introduction

Air Lift Performance thanks you for purchasing the most complete, fully engineered high-performance air suspension made for the 2021+ Acura TLX FWD & AWD. Read these installation instructions to correctly and safely set up the vehicle for a #lifeonair.

Air Lift assumes that the installer has the mechanical knowledge and ability to work on vehicle suspension systems and has basic tools necessary to complete a suspension replacement project. Special tools needed to complete the installation are noted on the *System Overview* page.

Air Lift reserves the right to make changes and improvements to its products and publications at any time. For the latest version of this manual, contact Air Lift Performance at **(800) 248-0892** or visit **www.airliftperformance.com**.

An Air Lift Performance air management system is highly recommended for this product. Learn more at **air-lift.co/productlines**.

NOTATION EXPLANATION

Hazard notations appear in various locations in this publication. Information which is highlighted by one of these notations must be observed to help minimize risk of personal injury or possible improper installation which may render the vehicle unsafe. Notes are used to help emphasize areas of procedural importance and provide helpful suggestions. The following definitions explain the use of these notations as they appear throughout this guide.



DANGER

INDICATES IMMEDIATE HAZARDS WHICH WILL RESULT IN SEVERE PERSONAL INJURY OR DEATH.



WARNING

INDICATES HAZARDS OR UNSAFE PRACTICES WHICH COULD RESULT IN SEVERE PERSONAL INJURY OR DEATH.



CAUTION

INDICATES HAZARDS OR UNSAFE PRACTICES WHICH COULD RESULT IN DAMAGE TO THE VEHICLE OR MINOR PERSONAL INJURY.



NOTE

Used to help emphasize areas of procedural importance and provide helpful suggestions.

System Overview

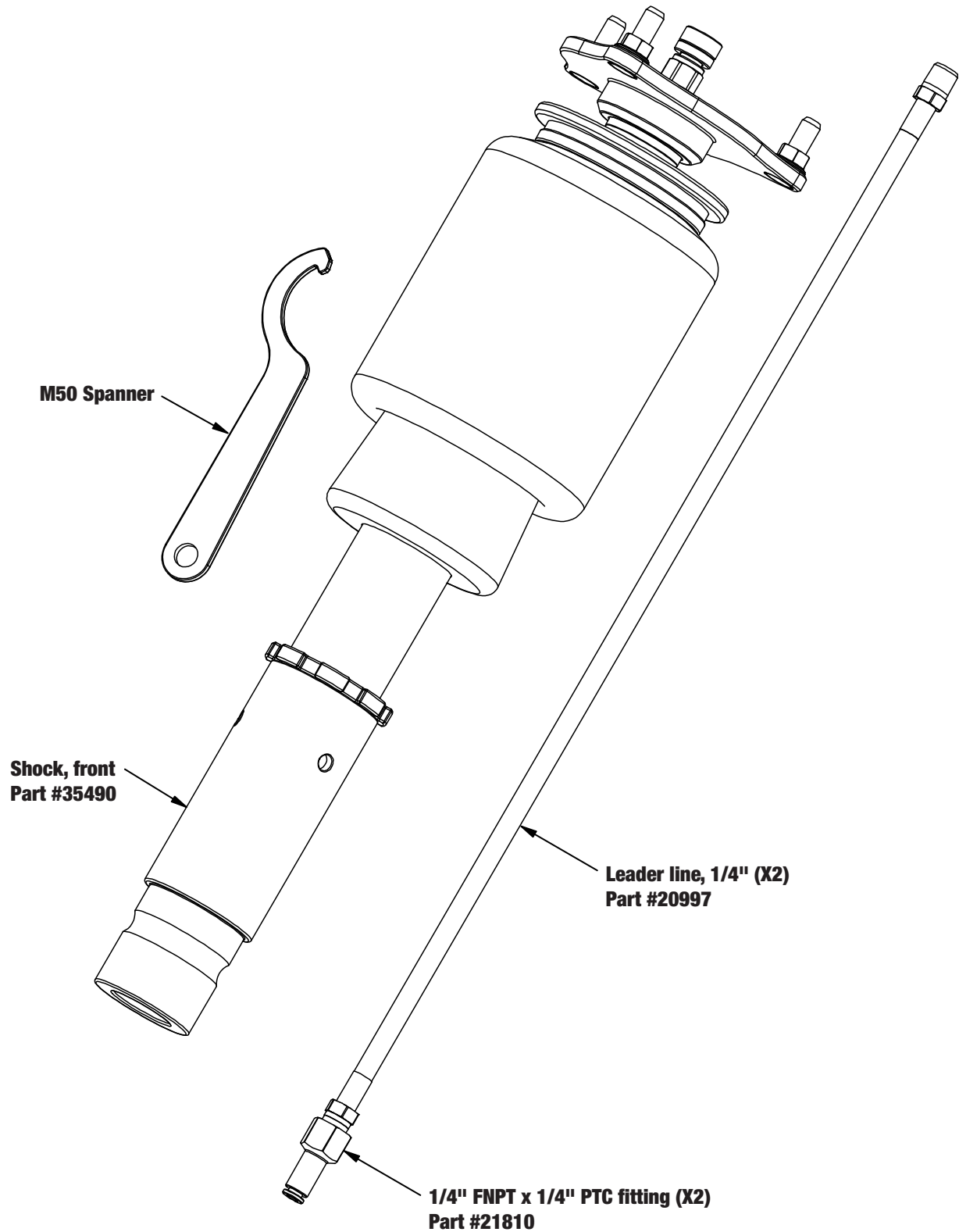

Missing or damaged parts? Call Air Lift customer service at (800) 248-0892 for a replacement part.

Installing the System

IMPORTANT SAFETY NOTICES



DO NOT INFLATE AIR SPRINGS WHILE OFF OF THE VEHICLE. DAMAGE TO ASSEMBLY MAY RESULT AND VOID WARRANTY.



DO NOT WELD TO OR MODIFY PERFORMANCE STRUTS/SHOCKS IN ANY WAY. DAMAGE TO UNIT MAY OCCUR AND WILL VOID WARRANTY.



AFTER INSTALLATION, ENSURE ALL ORIGINAL EQUIPMENT VEHICLE SAFETY FEATURES ARE PROPERLY CALIBRATED BY A QUALIFIED TECHNICIAN. CHANGING VEHICLE HEIGHT MAY AFFECT FUNCTIONING OF SAFETY SENSORS AND CAMERAS.

SECTION 1.

REMOVE THE SUSPENSION

1. Raise the vehicle and remove the wheel. Support the suspension with a jack.



2. Loosen and remove the sway bar end link nut. Detach the sway bar end link from the steering knuckle.



3. Loosen and remove the brake hose retainer bolt. Detach the brake hose from the steering knuckle.

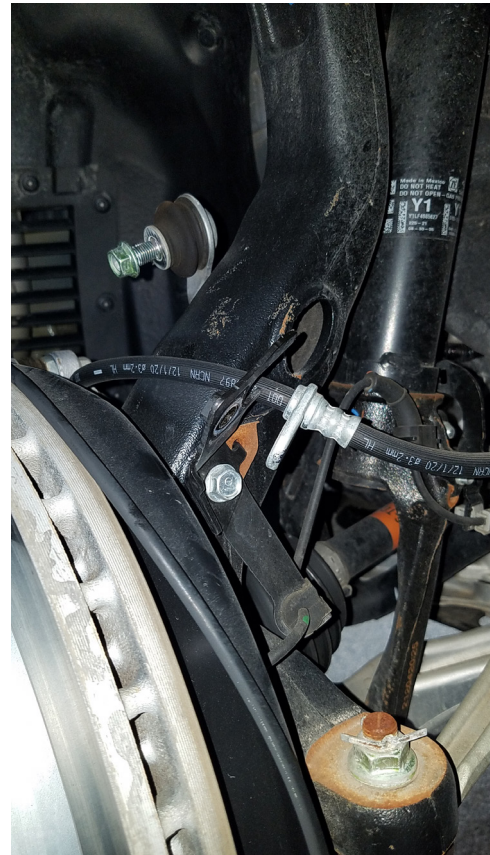

4. Loosen and remove the ABS sensor wire retainer bolt from the damper fork.

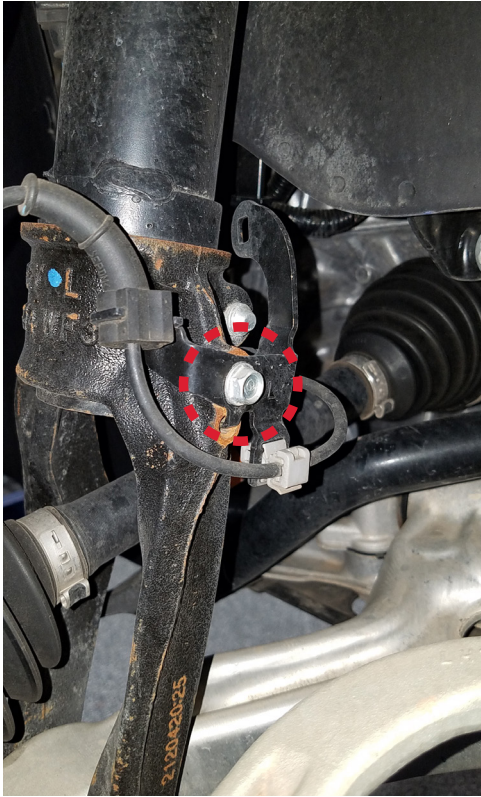

5. Remove the upper ball joint cotter pin. Loosen and remove the upper ball joint nut. Separate the upper ball joint from the steering knuckle.



6. Loosen and remove the damper fork upper and lower bolts.

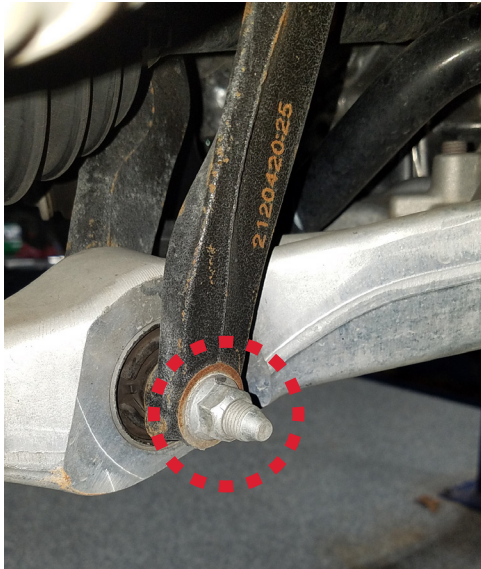

7. Slide the damper fork off the damper body and remove from the vehicle. Lower the jack if necessary to remove the damper fork.



8. Loosen and remove the damper upper mount nuts (3). Remove the damper from the vehicle.

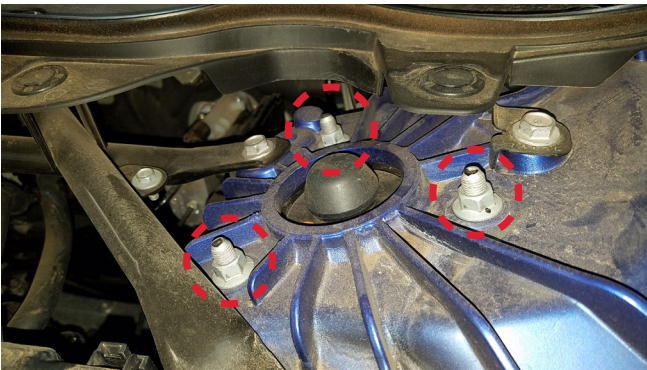

SECTION 2.**INSTALL THE AIR SUSPENSION**

1. Tighten the appropriate fitting to the air line one and three-quarter turns beyond hand-tight. Tighten the leader line into the air spring one and three-quarter turns beyond hand-tight.

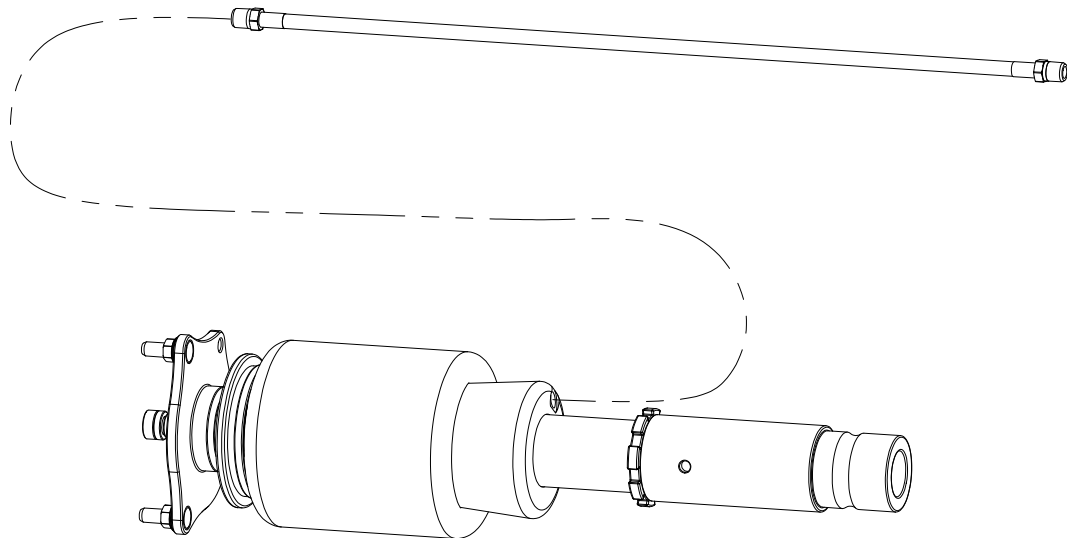

2. Insert the Air Lift Performance damper into the chassis and install the upper mount nuts. Torque the upper mount nuts (3) to 64Nm (47 lb.-ft.).



3. Reinstall the damper fork on the Air Lift Performance damper lower mount. Install the upper damper fork bolt and lower damper fork bolt and nut. Torque the upper damper fork bolt to 83Nm (61 lb.-ft.). Loosely install the lower damper fork nut but do not torque at this time.



4. Rejoin the upper ball joint with the steering knuckle. Reinstall the upper ball joint nut and torque to 39Nm (29 lb.-ft.). Align slot in upper ball joint nut with ball joint pin hole by tightening but do not exceed 49Nm (36 lb.-ft.). Never align by loosening the nut. Re-install the previously removed cotter pin or replace with a new cotter pin (not included).



5. Reinstall the ABS sensor wire retainer and bolt on the damper fork. Torque the ABS sensor wire retainer bolt to 22Nm (16 lb.-ft.).



6. Reinstall the brake hose retainer and bolt on the steering knuckle. Torque the brake hose retainer bolt to 9.5Nm (7 lb.-ft.).



7. Reinstall the sway bar end link and nut on the steering knuckle. Torque the sway bar end link nut to 59Nm (44 lb.-ft.).



SECTION 3. ROUTE THE AIR LINES



AFTER INSTALLATION, ENSURE ALL ORIGINAL EQUIPMENT VEHICLE SAFETY FEATURES ARE PROPERLY CALIBRATED BY A QUALIFIED TECHNICIAN. CHANGING VEHICLE HEIGHT MAY AFFECT FUNCTIONING OF SAFETY SENSORS AND CAMERAS.

1. Fully compress the suspension using a jack. With the suspension compressed, review the best routing for the air line that is clear of all suspension and steering components.
2. Routing should allow for the suspension to extend and steer without kinking, pulling the line tight or rubbing on other components. Following the brake line routing is often a good place to start. Check clearances to all other components.

AFTER INITIAL INSTALLATION OF SLEEVE-STYLE DAMPERS



DO NOT CYCLE THE SUSPENSION WITH THE AIR LINE CONNECTED TO THE LEADER LINE WITHOUT FIRST ADDING AIR SPRING PRESSURE. DOING SO MAY CAUSE THE AIR SPRING TO IMPROPERLY INFLATE (FIG. 1). IT IS SAFE TO CYCLE THE SUSPENSION TO CHECK FOR CLEARANCES ETC. WITH THE LEADER LINE OPEN TO ATMOSPHERE (DISCONNECTED FROM AIR LINE).



BEFORE SETTING VEHICLE ON THE GROUND FOR THE FIRST TIME, IT IS VERY IMPORTANT TO INFLATE THE AIR SPRINGS TO AT LEAST 3.5BAR (50 PSI). THIS WILL PREVENT ANY POSSIBILITY OF THE AIR SPRING KICKING OUT AND CAUSING A LEAK (FIGS. 1, 2 & 3).



Fig. 1

Caused by cycling with air line attached without pressure. Remove air-line from spring to release vacuum and re-attach. Inflate to more than 3.5BAR (50 PSI) before lowering car to ground.
Do NOT drive!



Fig. 2

Shows what spring looks like after lowering car to ground with less than 3.5BAR (50 PSI) and raising it with air pressure.
Do NOT drive!



Fig. 3

Shows what spring looks like when installed correctly.

1. Set the vehicle ride height and torque the lower damper fork bolt to 54Nm (40 lb.-ft.)

Finished Installation

The image shows the finished installation.



Congratulations!

You are now the proud owner of an industry leading Air Lift Performance air suspension system. Enjoy!

Before Operating

SET THE RIDE HEIGHT

1. Refer to the User Guide supplied with this kit to set up the suspension.

Torque Specifications		
Location	Nm	lb.-ft.
Upper damper mount nuts	64	47
Upper damper fork bolt	83	61
Lower damper fork nut	54	40
Upper ball joint nut	39-49	29-36
ABS sensor wire retainer bolt	22	16
Brake hose retainer bolt	9.5	7
Sway bar end link nut	59	44
Wheel lugnuts	127	94

2. Upon successful completion of the installation, follow these pressure requirements for the air springs.



FAILURE TO MAINTAIN ADEQUATE MINIMUM PRESSURE (OR PRESSURE PROPORTIONAL TO LOAD) MAY RESULT IN EXCESSIVE BOTTOMING OUT AND **WILL VOID THE WARRANTY.**

CHECK FOR BINDING



MAKE SURE THE FRONT WHEELS ARE STRAIGHT WHEN DEFLATING AND REINFLATING AIR SPRINGS.

1. Inflate and deflate the system (do not exceed 10.3BAR [150 PSI]) to check for clearance or binding issues. With the air springs deflated, check clearances on everything so as not to pinch brake lines, vent tubes, etc. Clear lines if necessary.
2. Inflate the air springs to 5.2-6.2BAR (75-90 PSI) and check all connections for leaks.

INSTALLATION CHECKLIST

- Clearance** — Inflate the air springs to 5.2-6.2BAR (75-90 PSI) and make sure there is at least 13mm (1/2") clearance from anything that might rub against the air spring. This should be checked with the air spring fully inflated and fully deflated.
- Leak** — Inflate the air springs to 5.2-6.2BAR (75-90 PSI) and check all connections for leaks. All leaks must be eliminated before the vehicle is road tested.
- Heat** — Be sure there is sufficient clearance from heat sources, at least 152mm (6") from air springs and air lines. If a heat shield was included in the kit, install it. If there is no heat shield, but one is required, call Air Lift customer service at **(800) 248-0892**.
- Fastener** — Recheck all bolts for proper torque.
- Road** — Inflate the air springs to recommended driving pressures (see previous page). Drive the vehicle 16km (10 miles) and recheck for clearance, loose fasteners and air leaks.
- Operating instructions** — If professionally installed, the installer should review the operating instructions with the owner. Be sure to provide the owner with all paperwork that came with the kit.

DAMPING ADJUSTMENT

1. The dampers in this kit have 30 settings, or “clicks,” of adjustable compression and rebound damping characteristics. Damping is changed through the damper rod using the supplied adjuster (example shown here) or a 3mm hex key (not included).

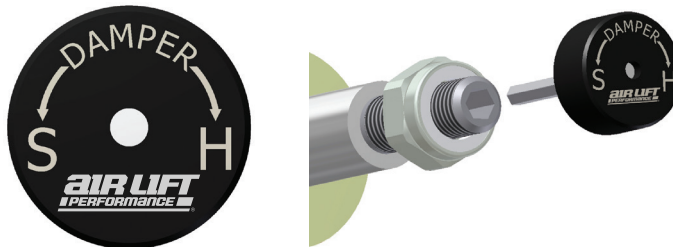

2. Turn the adjuster clockwise (H) and the damping settings are hardened, reducing oscillations and body motion. Turn the adjuster counterclockwise (S) and the damping is softened.
3. Each damper in this kit is preset to “-14 clicks.” This means that the damper is adjusted 14 clicks away from full stiff, which starts at 0. Counting up from full stiff is the preferred method of keeping track of, or setting, damping. This setting was developed on a 2021 Acura TLX A-Spec front wheel drive (FWD).

For more information, refer to the User Guide.

Limited Warranty and Return Policy

Air Lift Company provides a 1-year limited warranty* to the original purchaser of Air Lift Performance damper kits from the date of original purchase, that the products will be free from defects in workmanship and materials when used on cars and trucks as specified by Air Lift Company and under normal operating conditions, subject to the requirements and exclusions set forth in the full Limited Warranty and Return Policy.

* Full Limited Warranty and Return Policy are available at www.airliftperformance.com/warranty and are subject to change.

Warranty Registration & Claims

- To register your warranty, please visit <https://www.airliftperformance.com/support/warranty-registration/>
- To submit a warranty claim, please visit <https://www.airliftperformance.com/support/submit-warranty-claim/>

Thank you for purchasing Air Lift Performance products!

Need Help?

The Air Lift Company customer service department is open from 8 a.m. to 8 p.m. ET Monday through Friday. Call (800) 248-0892 or (517) 322-2144 for calls from outside the U.S. and Canada.



CONNECT BY SEARCHING FOR **AIR LIFT PERFORMANCE** #LIFEONAIR

AIR LIFT
PERFORMANCE

2727 Snow Road Lansing, MI 48917 or P.O. Box 80167 Lansing, MI 48908-0167
Toll Free (800) 248-0892 • Local (517) 322-2144 • Fax (517) 322-0240
www.airliftperformance.com



MADE IN USA
WITH GLOBAL
COMPONENTS

Air Lift Company reserves the right to make changes and improvements to its products and publications at any time. For the latest version of this manual, contact Air Lift Company at (800) 248-0892 or visit airliftperformance.com.