

**AIR LIFT**  
**PERFORMANCE**

# Kit 78156

Subaru WRX (VB)

**Front Application**

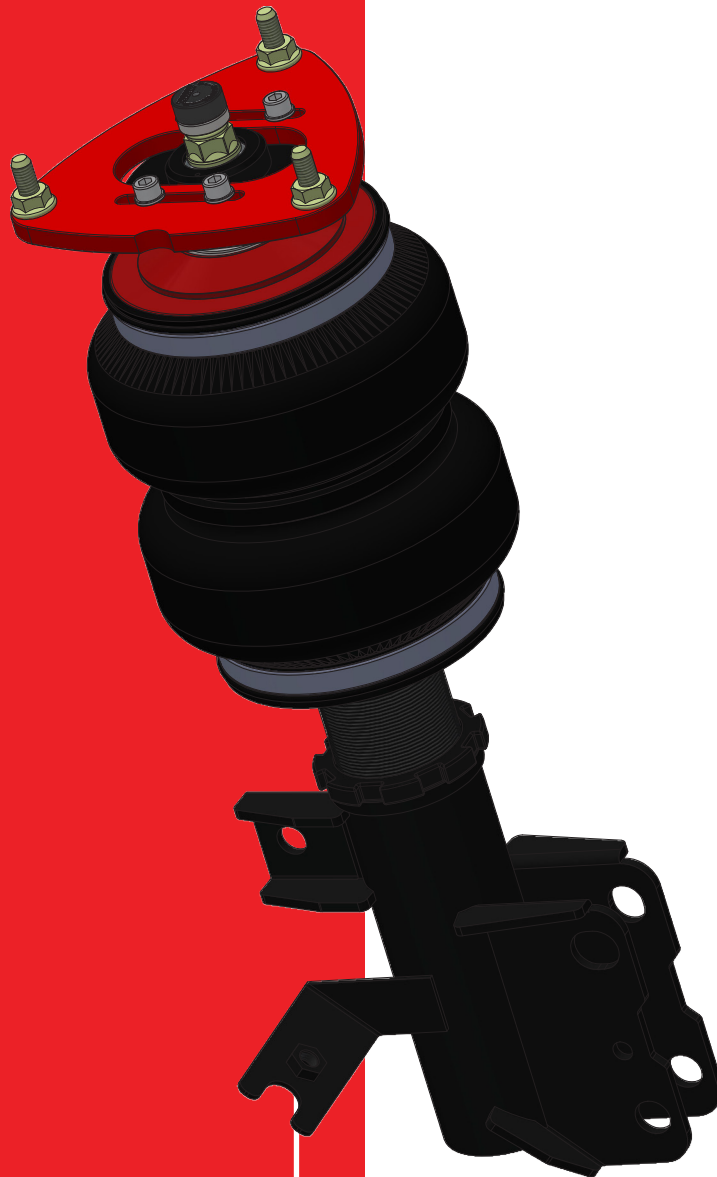

## INSTALLATION GUIDE

For maximum effectiveness and safety, please read these instructions completely before proceeding with installation.

*Failure to read these instructions can result in an incorrect installation.*

# **Protect your Air Lift Performance Purchase by Completing your Warranty Registration**



Thank you for purchasing an Air Lift Performance product!

Take a photo of your sales receipt and then scan the  
QR code to complete your online warranty registration.



## TABLE OF CONTENTS

<b>Introduction</b> .....	<b>2</b>
Notation Explanation .....	2
<b>Important Safety Notices</b> .....	<b>2</b>
<b>Installation Diagram</b> .....	<b>3</b>
Hardware List .....	3
<b>Installing the Air Suspension</b> .....	<b>4</b>
Preparing the Vehicle .....	4
Stock Suspension Removal .....	4
Installing the Kit Components .....	6
Routing the Air Lines .....	7
<b>Finished Installation</b> .....	<b>8</b>
<b>Before Operating</b> .....	<b>9</b>
Setting the Ride Height .....	9
Torque Specifications .....	9
Suggested Driving Air Pressure and Maximum Air Pressure .....	9
Check for Binding .....	9
Installation Checklist .....	10
Damping Adjustment .....	10
<b>Limited Warranty and Return Policy</b> .....	<b>12</b>



# Introduction

Air Lift Performance thanks you for purchasing the most complete, fully engineered high-performance air suspension made for the Subaru WRX (VB). Read these installation instructions to correctly and safely set up the vehicle for a #lifeonair.

Air Lift assumes that the installer has the mechanical knowledge and ability to work on vehicle suspension systems and has basic tools necessary to complete the project. Special tools needed to complete the installation are noted on the *Installation Diagram* page.

Air Lift Performance reserves the right to make changes and improvements to its products and publications at any time. For the latest version of this manual, contact Air Lift Performance at **(800) 248-0892** or visit **www.airliftperformance.com**.

An Air Lift air management system is highly recommended for this product. Learn more at **air-lift.co/productlines**.

## NOTATION EXPLANATION

Hazard notations appear in various locations in this publication. Information which is highlighted by one of these notations must be observed to help minimize risk of personal injury or possible improper installation which, may render the vehicle unsafe. Notes are used to help emphasize areas of procedural importance and provide helpful suggestions. The following definitions explain the use of these notations as they appear throughout this guide.

 **DANGER**

INDICATES IMMEDIATE HAZARDS WHICH WILL RESULT IN SEVERE PERSONAL INJURY OR DEATH.

 **WARNING**

INDICATES HAZARDS OR UNSAFE PRACTICES WHICH COULD RESULT IN SEVERE PERSONAL INJURY OR DEATH.

 **CAUTION**

INDICATES HAZARDS OR UNSAFE PRACTICES WHICH COULD RESULT IN DAMAGE TO THE MACHINE OR MINOR PERSONAL INJURY.

### NOTE

*Indicates a procedure, practice or hint which is important to highlight.*

## Important Safety Notices

 **WARNING**

DO NOT INFLATE AIR SPRINGS WHILE OFF OF THE VEHICLE. DAMAGE TO ASSEMBLY MAY RESULT AND VOID WARRANTY.

 **CAUTION**

DO NOT WELD TO OR MODIFY PERFORMANCE STRUTS/SOCKS IN ANY WAY. DAMAGE TO UNIT MAY OCCUR AND WILL VOID WARRANTY.

 **WARNING**

AFTER INSTALLATION, ENSURE ALL ORIGINAL EQUIPMENT VEHICLE SAFETY FEATURES ARE PROPERLY CALIBRATED BY A QUALIFIED TECHNICIAN. CHANGING VEHICLE HEIGHT MAY AFFECT FUNCTIONING OF SAFETY SENSORS AND CAMERAS.

# Installation Diagram

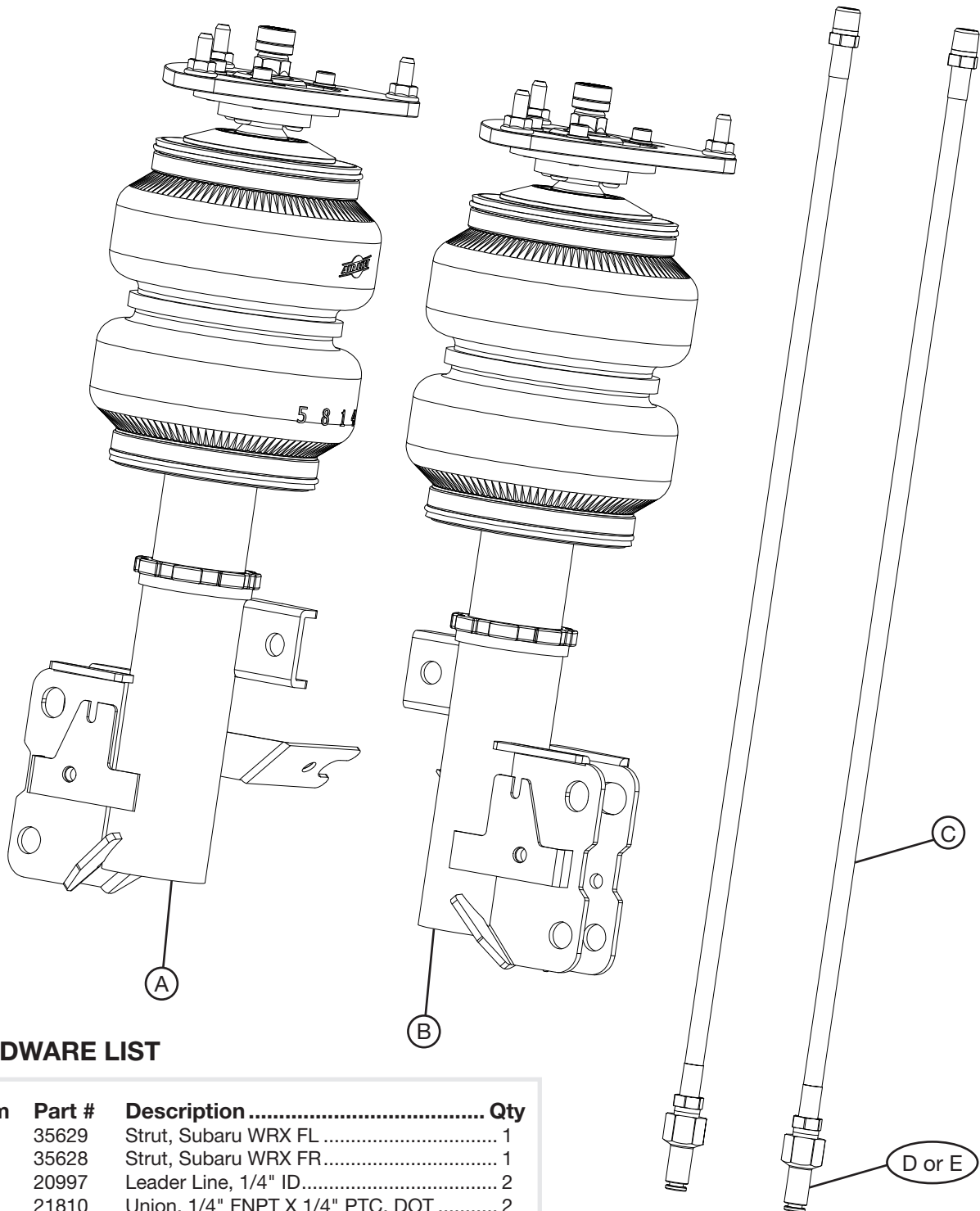

## HARDWARE LIST

Item	Part #	Description .....	Qty
A	35629	Strut, Subaru WRX FL .....	1
B	35628	Strut, Subaru WRX FR .....	1
C	20997	Leader Line, 1/4" ID .....	2
D	21810	Union, 1/4" FNPT X 1/4" PTC, DOT .....	2
E*	21987	Union, 1/4" FNPT X 3/8" PTC, DOT .....	2
F		Spanner Wrench (not shown) .....	1

\*1/4" FNPT x 3/8" PTC fittings are NOT included in this kit but are available as a special order.

*fig. 1*

**STOP!** Missing or damaged parts? Call Air Lift customer service at (800) 248-0892 for a replacement part.

# Installing the Air Suspension

**NOTE**

See important safety notices on page 2.

## PREPARING THE VEHICLE

1. Elevate and support the vehicle with a hoist or safety stands.
2. Remove the front wheel and support the lower control arm with a jack. (Fig. 2)



*fig. 2*

## STOCK SUSPENSION REMOVAL

1. Remove bolt holding brake line to tab. (Figs. 3 & 4)

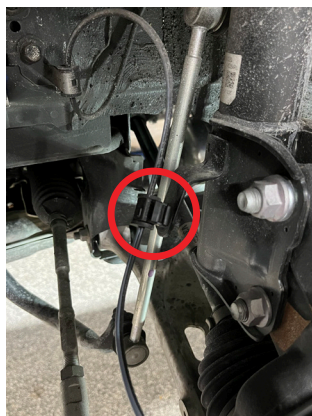

*fig. 3*



*fig. 4*

2. Remove wheel speed sensor cable clip from tab. Release the clip by squeezing the tabs with pliers. (Figs. 5 & 6)



*fig. 5*



*fig. 6*

3. Remove the two lower strut bolts and separate the strut from the knuckle (Fig. 7).



*Remember which bolt you remove from which position because it will be noted later.*

4. Remove the upper and lower sway bar link bolts (Fig. 8)

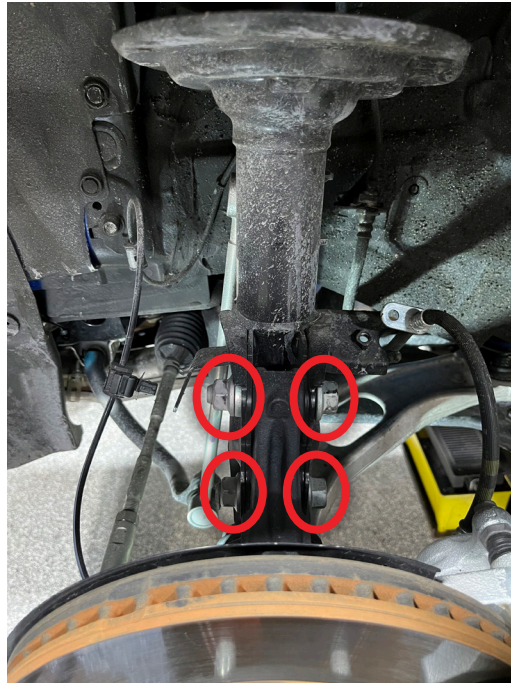

*fig. 7*

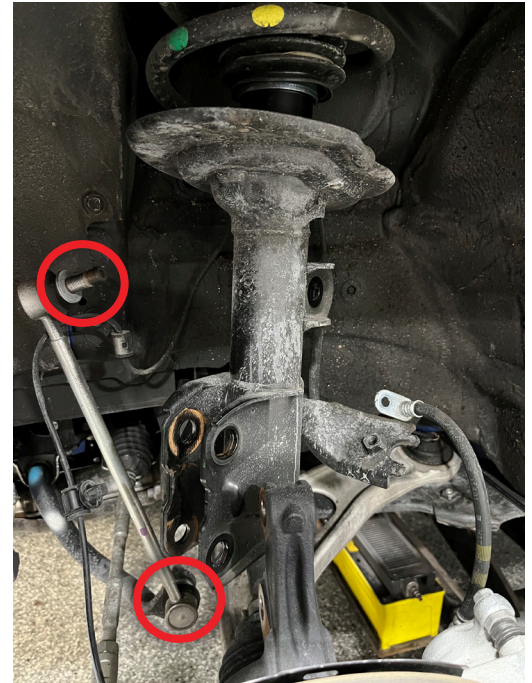

*fig. 8*

5. Remove the nuts from the upper mount in the engine compartment and remove the strut from the vehicle. (Fig. 9)



*fig. 9*

## INSTALLING THE KIT COMPONENTS

1. Begin by installing the leader line into the air spring. Apply thread sealant to the threads of the leader line. Tighten the appropriate fitting to the air line (1 3/4 turns beyond hand-tight). Tighten the leader line into the air spring 1 3/4 turns beyond hand-tight. (Fig. 10)

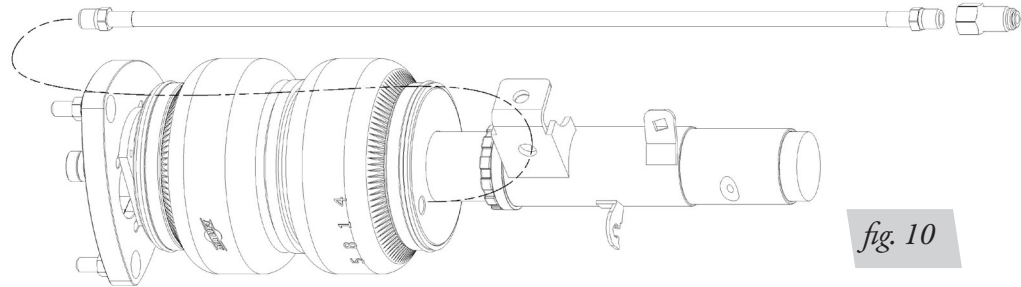

*fig. 10*

2. Attach the strut to the chassis by bolting the camber plate to the strut tower. Tighten the nuts to 20Nm (15 lb.-ft.) for 2021 or 32Nm (23.6 lb.-ft.) for 2022. (Fig. 11)



*fig. 11*

3. Attach the strut to the knuckle by sliding the lower mount over the knuckle and inserting the bolts into the lower mount. Be sure that the cam bolt goes in the top hole of the lower mount. Install the nuts and torque to 155Nm (115 lb.-ft.) (Fig. 12).



*fig. 12*



4. Attach the wheel speed sensor bracket to the strut using the included M8 bolt (Figs. 13 & 14). Torque to 24Nm (18 lb.-ft.).
5. Insert the wheel speed sensor clip into the tab on the strut. (Fig. 14)

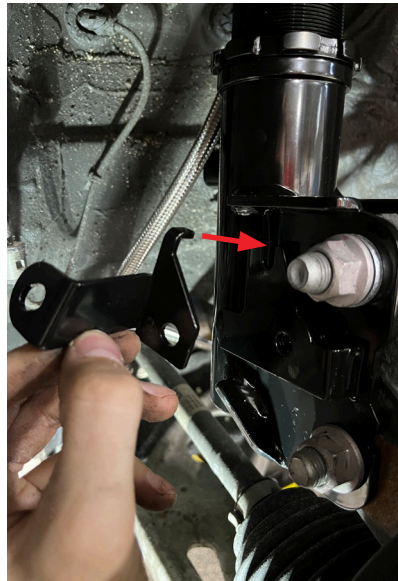

Wheel speed sensor clip

*fig. 13*

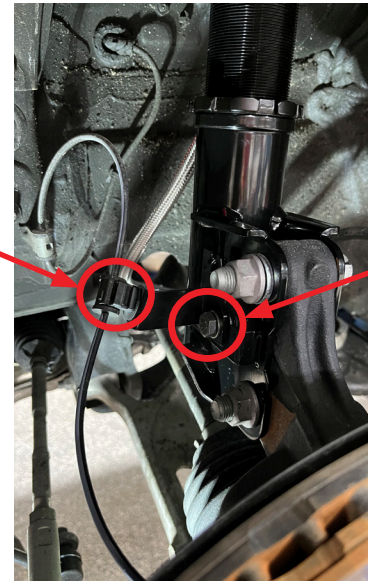

M8 Bolt

*fig. 14*

6. Bolt the brake line to the tab on the strut and torque to 33Nm (24 lb.-ft.). (Fig. 15)
7. Install the included end links and torque nuts to 60Nm (44 lb.-ft.). (Fig. 15)

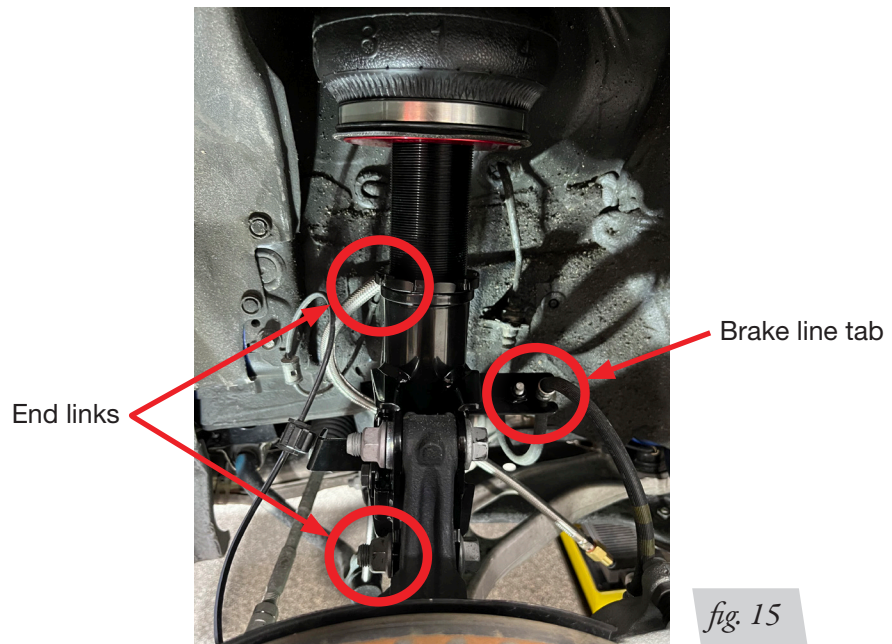

End links

Brake line tab

*fig. 15*

## ROUTING THE AIR LINES

1. Fully compress the suspension using a jack. With the suspension compressed, review the best routing for the leader line that is clear of all suspension and steering components.
2. Routing should allow for the suspension to extend and steer without kinking, pulling the line tight, or rubbing on other components. Following the brake line routing is often a good place to start. Check clearances to all other components.

## Finished Installation

The image shows the finished strut installation (end link not shown).



## Congratulations!

You are now the proud owner of an Air Lift Performance air suspension system. Enjoy!

# Before Operating

## SETTING THE RIDE HEIGHT

Please refer to the User Guide supplied with this kit to set up the suspension.

Torque Specifications		
Location	Nm	Lb.-ft.
Camber plate to chassis	20 (32Nm for 2022)	15 (23.6 for 2022)
Camber plate adjustment	15	11
Lower mount bolts	155	115
Brake line tab bolts	33	24
Front sway bar end link nuts	60	44
Wheel speed sensor bolt	24	18
Lugnuts	120	88.5
Leader line threads	1 3/4 turns beyond hand-tight	

Table 1

Suggested Driving Air Pressure	Maximum Air Pressure
<b>50 PSI (3.45BAR)</b>	<b>125 PSI (8.6BAR)</b>
FAILURE TO MAINTAIN ADEQUATE MINIMUM PRESSURE (OR PRESSURE PROPORTIONAL TO LOAD) MAY RESULT IN EXCESSIVE BOTTOMING OUT AND <b>WILL VOID THE WARRANTY.</b>	

Table 2

## CHECK FOR BINDING

1. Inflate and deflate the system (do not exceed 125 PSI [8.6BAR]) to check for clearance or binding issues. With the air springs deflated, check clearances on everything so as not to pinch brake lines, vent tubes, etc. Clear lines if necessary.
2. Inflate the air springs to 75-90 PSI (5.2-6.2BAR) and check all connections for leaks.



**MAKE SURE THE FRONT WHEELS ARE STRAIGHT WHEN DEFLATING AND REINFLATING AIR BAGS.**

## INSTALLATION CHECKLIST

- Clearance** — Inflate the air springs to 75-90 PSI (5.2-6.2BAR) and make sure there is at least 1/2" (13mm) clearance from anything that might rub against the air spring. This should be checked with the air spring fully inflated and fully deflated.
- Leak** — Inflate the air springs to 75-90 PSI (5.2-6.2BAR) and check all connections for leaks. All leaks must be eliminated before the vehicle is road tested.
- Heat** — Be sure there is sufficient clearance from heat sources, at least 6" (152mm) from air springs and air lines. If a heat shield was included in the kit, install it. If there is no heat shield, but one is required, call Air Lift customer service at **(800) 248-0892**.
- Fastener** — Recheck all bolts for proper torque.
- Road** — Inflate the air springs to recommended driving pressures (Table 2). Drive the vehicle 10 miles (16km) and recheck for clearance, loose fasteners and air leaks.
- Operating instructions** — If professionally installed, the installer should review the operating instructions with the owner. Be sure to provide the owner with all paperwork that came with the kit.

## DAMPING ADJUSTMENT

1. The dampers in this kit have 30 settings, or "clicks," of adjustable compression and rebound damping characteristics. Damping is changed through the damper rod using the supplied adjuster (Figs. 17 & 18) or a 3 mm hex key (not included).
2. Turn the adjuster clockwise (H), and the damping settings are hardened, reducing oscillations and body motion. Turn the adjuster counterclockwise (S), and the damping is softened.
3. Each damper in this kit is preset to "-20 clicks." This means that the damper is adjusted 20 clicks away from full stiff, which starts at 0. Counting up from full stiff is the preferred method of keeping track of, or setting, damping. This setting was developed on a 2022 Subaru WRX.



fig. 16

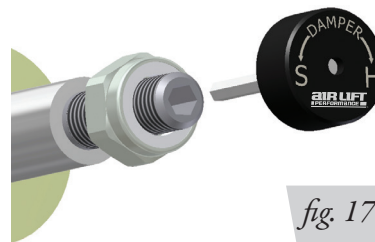

fig. 17

# Notes

# Limited Warranty and Return Policy

Air Lift Company provides a 1-Year Limited Warranty\* to the original purchaser of Air Lift Performance damper kits from the date of original purchase, that the products will be free from defects in workmanship and materials when used on cars and trucks as specified by Air Lift Company and under normal operating conditions, subject to the requirements and exclusions set forth in the full Limited Warranty and Return Policy.

\*Full Limited Warranty and Return Policy are available at [www.airliftperformance.com/warranty](http://www.airliftperformance.com/warranty) and are subject to change.

## Warranty Registration & Claims

- To register your warranty, please visit <https://www.airliftperformance.com/support/warranty-registration/>
- To submit a warranty claim, please visit <https://www.airliftperformance.com/support/submit-warranty-claim/>

Air Lift Company reserves the right to make changes and improvements to its products and publications at any time. For the latest version of this manual, visit [www.airliftperformance.com](http://www.airliftperformance.com).



## Need Help?

Contact Air Lift Company customer service department by calling (800) 248-0892. For calls from outside the USA or Canada, dial +1 (517) 322-2144.



Connect by searching for **Air Lift Performance** #LifeonAir



*Thank you for purchasing Air Lift Performance products!*



Air Lift Performance • 2727 Snow Road • Lansing, MI 48917 or P.O. Box 80167 • Lansing, MI 48908-0167  
Toll Free (800) 248-0892 • Local (517) 322-2144 • Fax (517) 322-0240 • [www.airliftperformance.com](http://www.airliftperformance.com)

Printed in the USA  
JJC-0423

California: ⚠️WARNING: Cancer and Reproductive Harm - [www.P65Warnings.ca.gov](http://www.P65Warnings.ca.gov)