

LIMITED LIFETIME WARRANTY



Contact us for service under the warranty

Phone: 1 (800) 222-7023
Email: warranty@roughcountry.com
Website: www.roughcountry.com

WARRANTY DETAILS

Rough Country warrants our product to be free from defects in material and workmanship on all aluminum framing, plastics, and hardware for a limited lifetime against manufacturer defects after date of purchase.

If you discover a defect in a product covered by this warranty we will, at our option, repair the product using new or refurbished components, or if repair is not possible, replace the item.

EXCLUSIONS

This warranty covers defects in manufacturing discovered while using the product as recommended for use on the truck model it was intended for.~ The warranty does not cover improper service or installation, loss or theft, nor does coverage extend to damage caused by misuse, abuse, unauthorized modification, improper storage conditions, acts of God, wind or weather related damage, normal wear and tear or other causes not arising from defective materials or workmanship. The warranty does not cover parts that are subject to normal wear and tear replacement requirements. Rough Country does not warranty any tonneau covers that come off while driving, **it is the users responsibility to check clamps before driving to avoid any "Blown off covers"**.

Rough Country requests a Warranty Claim Form is submitted and based on information provided will determine the legitimacy of the warranty. Upon determination, Rough Country may require the product to be returned, only authorized returns with an appropriate RGA# will be accepted as a return. Returned items do not constitute an accepted warranty. Until accepted in writing, to either the vendor or end user, Rough Country will not issue credit or replacement of products. Warranty will be issued solely at Rough Country's discretion.

IMPORTANT NOTICE

Ensure the cover is firmly fastened in either the fully closed or fully open position. Do not over tighten clamps and check clamps regularly.

Only use mild soap and water to clean and condition the tonneau cover.

Cargo must not be allowed to touch the cover in any position. Rough Country does not recommend placing items on top of the cover, as it may damage the cover.

LIMITS OF LIABILITY

Should the product fail, your sole recourse shall be repair or replacement, as described in the preceding paragraphs. We will not be held liable to you or any other party for any damages that result from the failure of this product. Damages exclude, but are not limited to, the following: lost profits, lost savings, damage to other equipment, and incidental or consequential damages arising from the use, or inability to use this product. In no event will Rough Country be liable for more than the amount of your purchase price, not to exceed the current recommended list price of the product, and excluding tax, installation, shipping and handling charges.

The Warranty applies only to the original retail consumer. Warranty is void if the product has been removed or installed on a different vehicle than the original product was purchased. Rough Country disclaims any other warranties or guarantees, express or implied. By installing or using the product, the user accepts all terms and conditions described herein.

REQUIREMENTS

The cost of shipping or related charges to the manufacturer, or authorized repair center as well as payment of any custom clearance fees or duties are the responsibility of the user without the express written consent from Rough Country.

Certain documentation (including original purchase receipt with product description and date) and pictures may be required for warranty review of product.

INSTALLATION SHEET RC#43120580



HARD, THREE PANEL COVER

Open the cardboard box from the top and take out all the bagged parts leaving the cover inside. Please check that you have all the parts listed. If you find anything missing or damaged, please give us call on our customer service number.

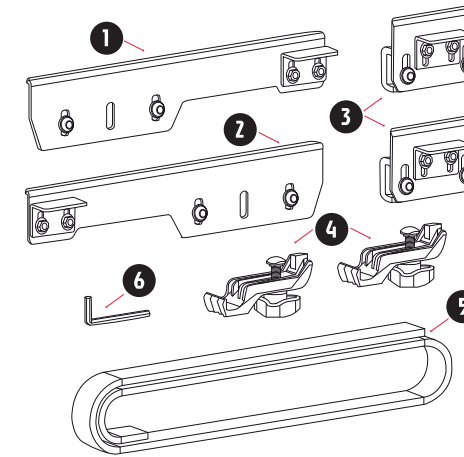

Packing List:

- 1 X 43120580 - Chevy/GMC 1500 (19-23) 5'9" Tonneau Cover
Hardware Kit:
- 1) 1 X #100312 Rear Striker Long Bracket, Right Hand Side
 - 2) 1 X #100311 Rear Striker Long Bracket, Left Hand Side
 - 3) 2 X #100207 Middle Striker Brackets
 - 4) 2 X #100227 Retainer Hook Assembly
 - 5) 1 X #100267 Bulkhead Wall Seal
 - 6) 1 X #100378 5mm Hex Allen Key

Tools Required:

- Utility Knife
- No. 1 or No. 2 Phillips Head Screwdriver
- 10mm box/open wrench

STEP ONE

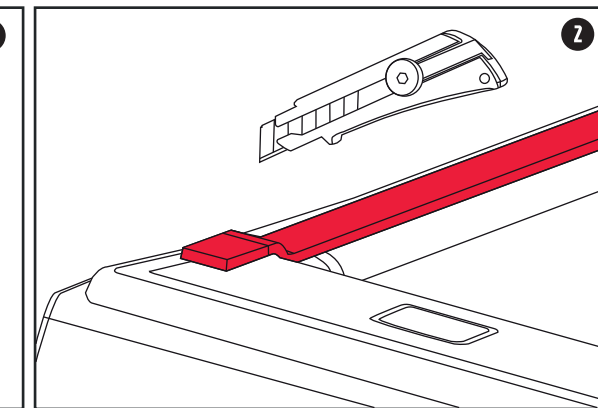
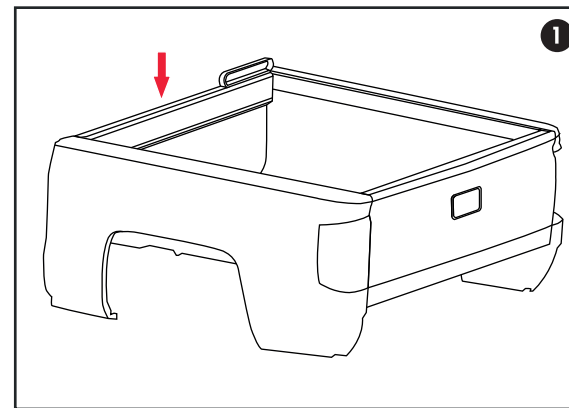

1. Clean the bulkhead wall of your truck bed if required. Unpack the bulkhead wall seal (item #5). Pull off the liner and apply the adhesive foam seal.

2. Make sure not to leave any gap between the seal and the side plastic caps of the bed. Cut the excess length using a knife if required.

STEP TWO

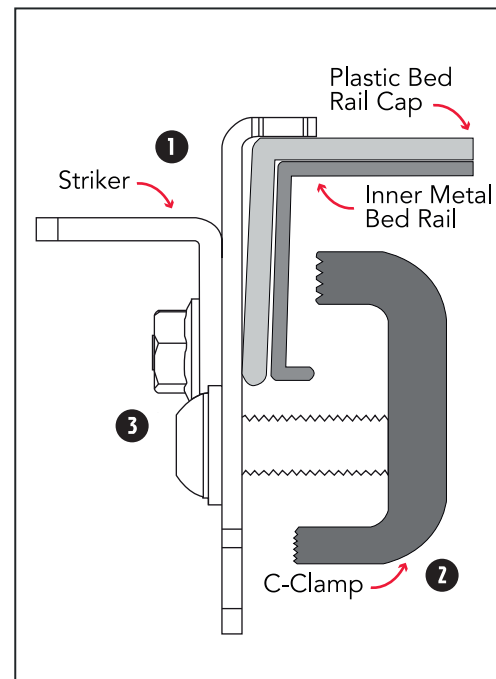

1. Identify and install the latch striker brackets (items #1, #2 and #3). Check the packing list for a detailed description of each part.

2. If required, loosen the two C-clamps on each bracket and place them on the bed rail one by one. Ensure the two C-clamps are behind the plastic and metal bed rail layers as in the picture.

3. Slightly fasten the brackets as shown using the hex key (item #6) so that they do not fall off. Do not fully tighten the clamps at this point.

STEP THREE

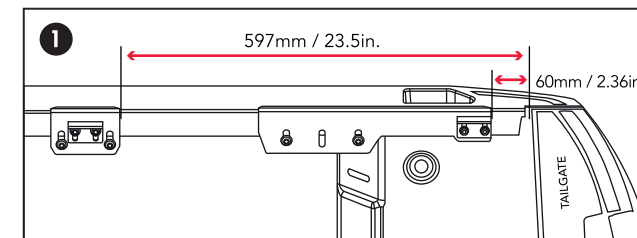

1. Keep the tailgate closed and use a tape measure to approximately locate the striker brackets at the shown distance from the inside edge of the tailgate as displayed.

2. Maintain the same distance for the opposite side brackets and completely tighten the clamps using the hex key

STEP FOUR

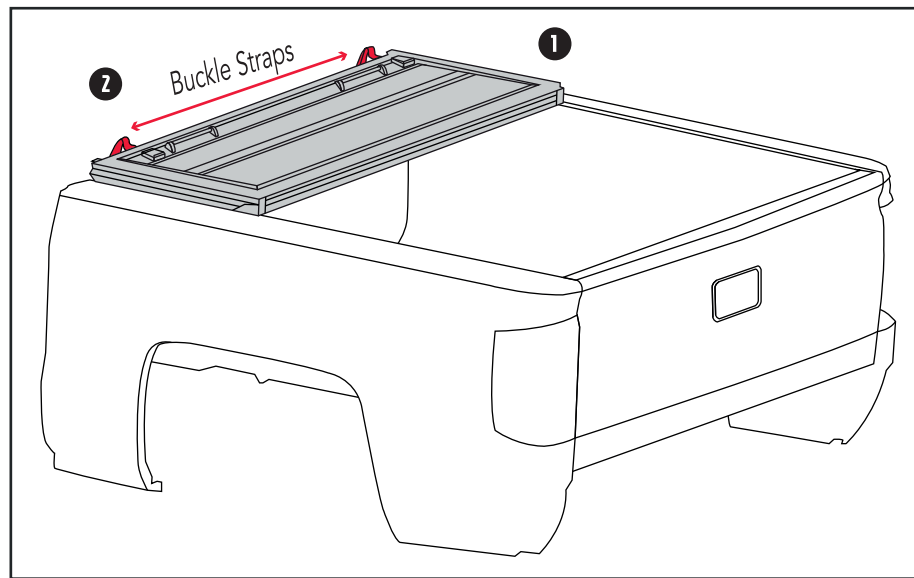

1. With assistance from another person, take the tonneau cover from the box and place it near the bulkhead of the truck.
2. Make sure that the buckle straps are facing the cabin and the cover remains folded.

STEP FIVE

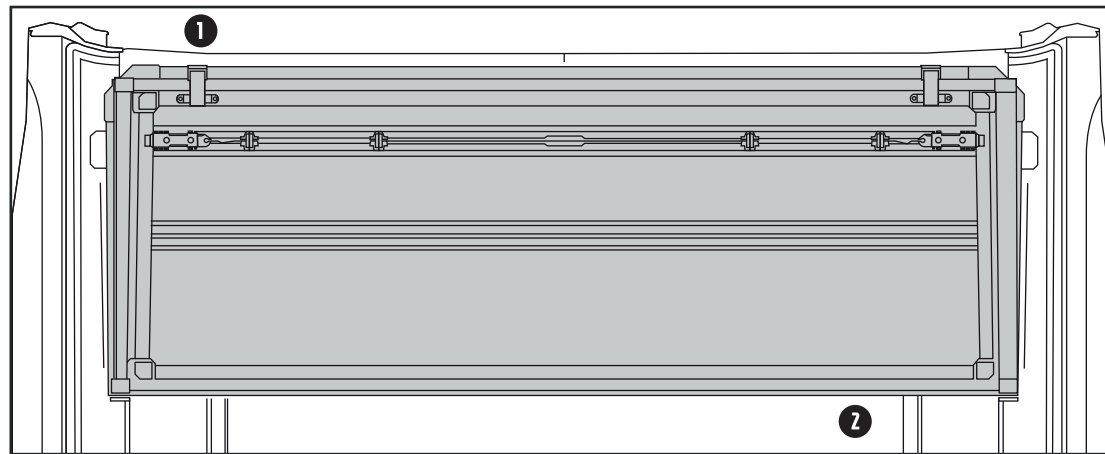

1. Align the tonneau cover on the bulkhead to the truck bed evenly spaced over the truck bed rails.
2. Ensure that the bulkhead fin seals are properly sitting on the previously applied adhesive foam seal (item #5).

STEP SIX

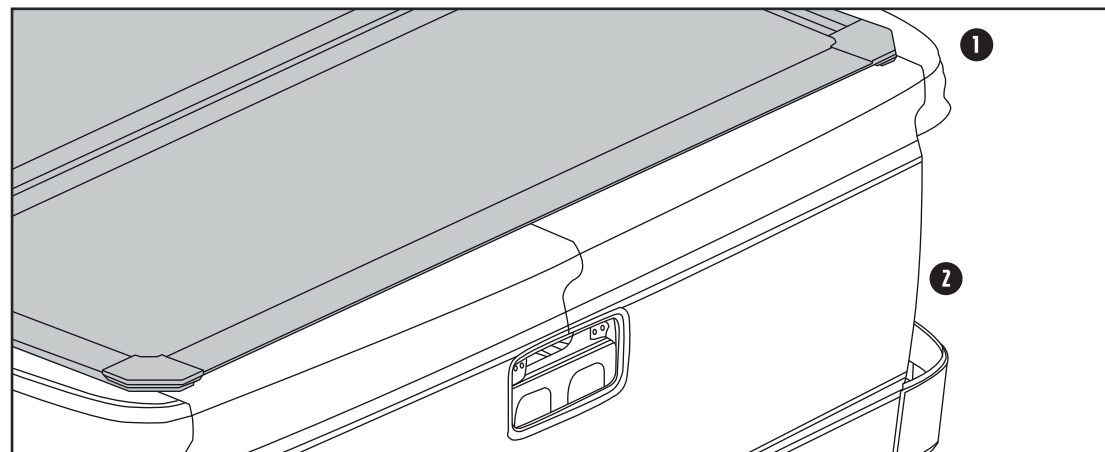

1. Close the tailgate and completely unfold the cover to check if it properly aligns on the tailgate.
2. Move the cover to the front and back or left and right as required to ensure it's evenly spaced and sealing the truck bed.

Once the cover is correctly situated, fold it gently open so the tonneau does not move from the aligned position.

STEP SEVEN

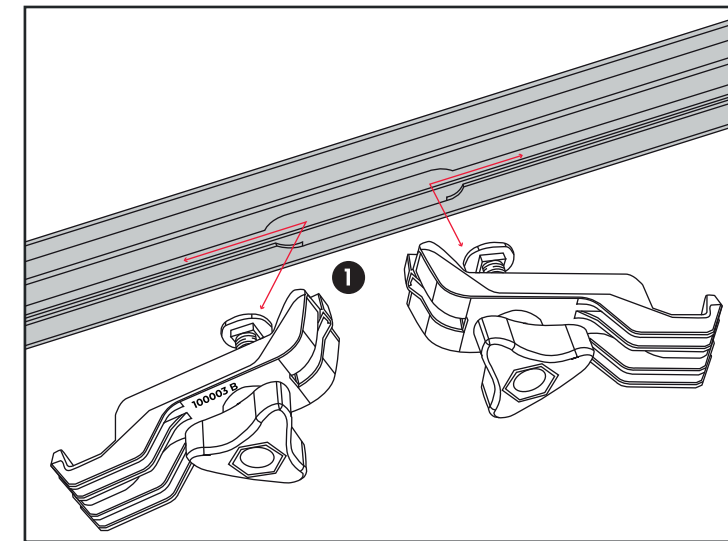

1. Locate the cutout in the center of the front panel crossbeam. Install bulkhead latches (item #4s) on both the sides of cover one by one as shown in the picture above.

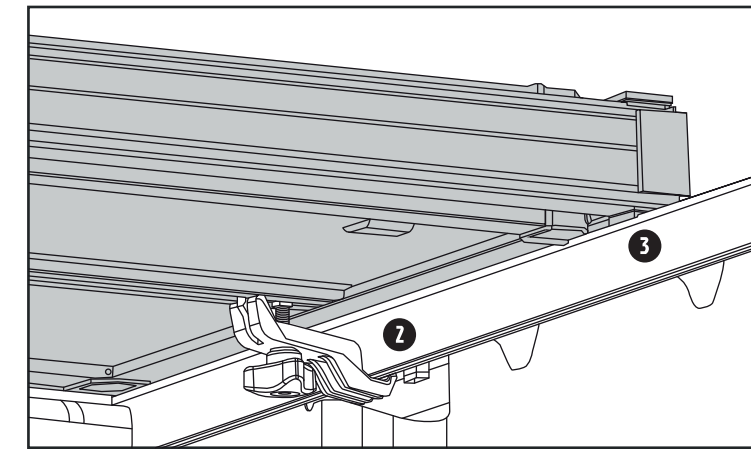

2. Slide the latches towards the side walls of your truck bed. Lower the hook down by loosening the knob. Slide the latch hook under bed rail lip. Ensure the hook is positioned under both the plastic and metal layers of the bed rail lip. Tighten the knob to secure the latch.
3. Stop threading the knob when you see the side seal and foam start compressing against the bed cap. Repeat the same process on other side and make sure the cover is secured.

STEP EIGHT

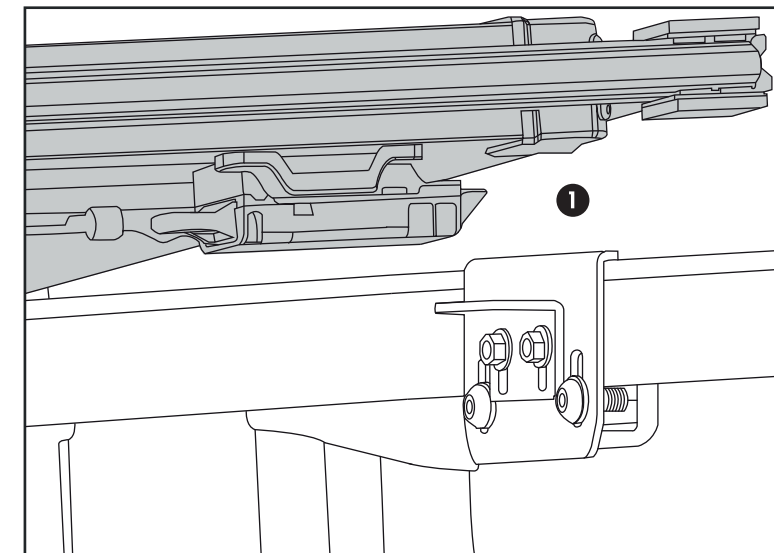

1. Unfold the cover and check if the smart latch systems align and engage properly with the middle and rear striker brackets. Loosen the clamps and move the striker brackets as needed.

STEP NINE

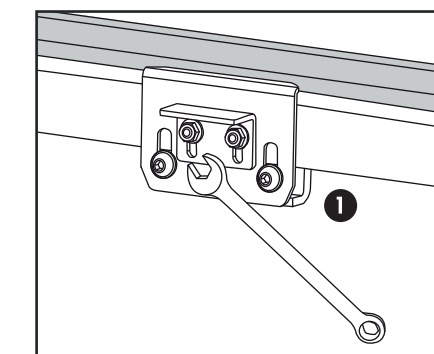

1. If required adjust the striker height and latch position using a 10mm wrench.

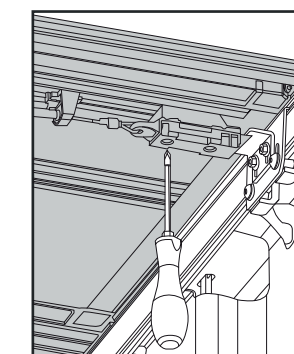

2. Completely fold and unfold the tonneau cover a couple of times to make sure it functions properly.

If needed, adjust the position of the quick latches using a #2 Phillips screwdriver. Loosen both screws and slide the quick latch to engage the striker approximately 6mm (1/4"). Tighten screws securely.