

PART NO. 25445

Instruction Sheet

TOYOTA REPLACEMENT CAMBER/CASTER CAM KIT

This part should only be installed by personnel who have the necessary skill, training and tools to do the job correctly and safely. Incorrect installation can result in personal injury, vehicle damage and / or loss of vehicle control.

Plan Ahead - Read All Instructions BEFORE installing part.

Check for loose or worn parts, proper tire pressure, and odd tire wear patterns before beginning alignment.

1. Before beginning alignment, inspect for loose or worn parts and replace as necessary, check tire pressure, and look for odd tire wear.
2. Raise front of vehicle and properly support it by frame so suspension hangs free.
3. Pre-assemble SPC cam assemblies by first installing a 80002003 cam and then a tube spacer on each bolt.
4. One at a time, remove original cam assemblies from lower control arm and replace them with the SPC assembly, installing new assemblies as shown in *Figure 1*. The longer of the two bolts is used with the wider lower control arm bushing.

SPC tool 40915 may help with removal of OEM cams. However, if tubes are solidly seized in bushings, you may not be able to remove them. To achieve camber/ caster change, you may need to replace upper control arms with SPC Part No. 25485.

Note: The rear cams of the control arm are trapped in vehicle by the steering rack. To avoid removing rack, drive them rearward as far as possible and cut off protruding part of sleeve. This should allow the rest of the sleeve to be driven out. Install SPC cam kit from the front as shown in *Figure 1*.

5. Install 80002005 cam washer and nut on each bolt and loosely tighten.
6. Lower vehicle, jounce suspension, and use cams to adjust alignment to desired settings by turning the bolt.
7. Hold head of bolt and tighten nut to 150 ft-lb to lock settings. **Always check for proper clearance between suspension components and other components of the vehicle.**
8. Adjust toe and road test vehicle.

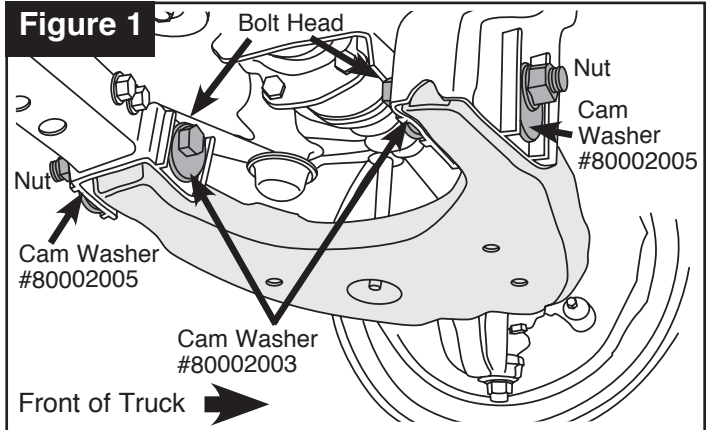

Specialty Products Company®

4045 Specialty Place • Longmont, CO 80504 • (303) 772-2103 • Fax: (303) 772-1918
www.specprod.com • Email: info@specprod.com • Toll Free Technical Hot Line: 1-800-525-6505
For warranty information go to: www.specprod.com/warranties ECN#2853

©2021 Niwot Corp. dba Specialty Products Co® • Printed in U.S.A. • Form No. 25445INS • Rev. 3/21