

This part should only be installed by personnel who have the necessary skill, training and tools to do the job correctly and safely. Incorrect installation can result in personal injury, vehicle damage and / or loss of vehicle control.

Plan Ahead - Read All Instructions BEFORE Installing Part

Check for loose or worn parts, proper tire pressure, and odd tire wear patterns before beginning alignment.

1. Record initial alignment readings and determine amount of caster and camber change required.
2. Raise vehicle and support by frame.
3. Remove front tire and wheel assembly. Using SPC Magnetic Camber Gauge #81139, mark current camber reading.
4. Remove OE front upper control arm per manufacturer's procedure. To break ball joint taper, use SPC P/N 8370 or equivalent. It may be necessary to remove vacuum solenoids or coolant tank to gain access to nuts. Strut and sway bar link may need to be loosened and repositioned to remove control arm bolts.

NOTE: Support spindle to prevent strain on ABS wiring or brake line.

5. Install SPC control arm with 'L' or 'R' facing up corresponding to left side or right side of vehicle. Reinstall and tighten any loosened strut or sway bar link hardware. Loosely install mounting hardware.

NOTE: Tightening arm fasteners with vehicle in raised position will cause premature bushing failure.

6. If vehicle is equipped with adaptive damping:
 - For 66040 and 66045: Using supplied M6 bolt with anti-seize, install supplied mounting bracket to SPC control arm with tab oriented forward and downward. Install sensor reusing OE nut. (Figure 1)
 - For 66047: Using Ø1.0" P-clip, install sensor rod through P-clip eyelet and fasten with washer and nut in approximate location of sensor on OE arm.
6. Using chart below, set orientation of star plate for desired caster change.

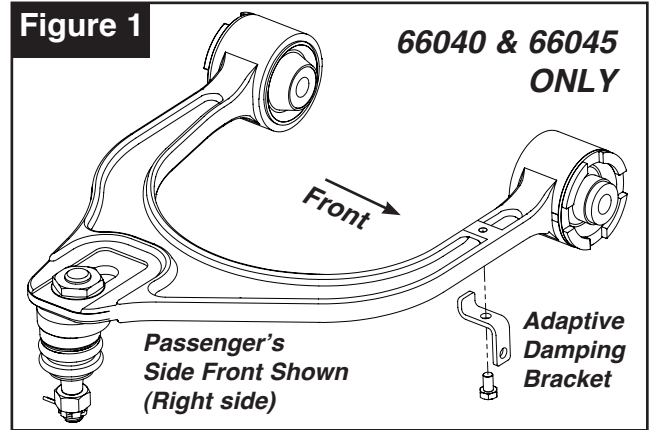

LEFT FRONT CASTER CHANGE

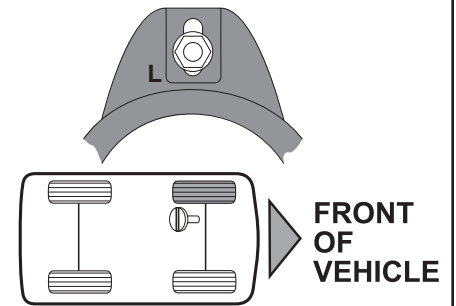
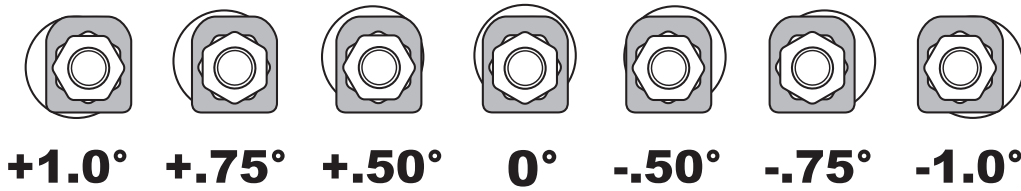

RIGHT FRONT CASTER CHANGE

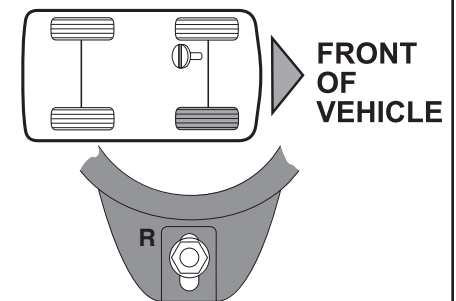
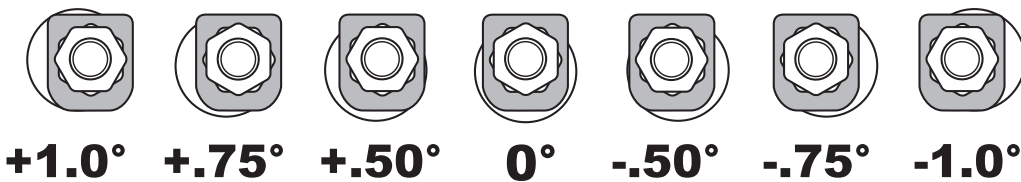

7. Install ball joint assembly into control arm and loosely install top washer and nut.
8. Install ball joint stud into spindle. Torque castle nut to manufacturer's specification.
9. Using SPC Magnetic Camber Gauge #81139, slide ball joint to adjust camber to desired setting. Torque adjusting nut to 120 ft-lb (162 Nm).
10. Reinstall tire and wheel assembly and lower vehicle. Torque arm mounting hardware to manufacturer's specification.
11. Recheck camber/caster settings and adjust as necessary. Complete alignment and road test vehicle.

Always check for proper clearance between suspension components and other components of the vehicle.



Specialty Products Company®