



**Instruction Sheet  
ADJUSTABLE REAR ARMS**

*This part should only be installed by personnel who have the necessary skill, training and tools to do the job correctly and safely. Incorrect installation can result in personal injury, vehicle damage and / or loss of vehicle control.*

1. Always check for loose or worn parts, tire pressure and tire wear.
2. Raise vehicle directly under rear coil springs so suspension is loaded and support with safety stands. Remove rear wheel assembly.
3. Remove stock rear upper control arm by removing both inner and outer bolts.
4. Adjust the new control arm so the outer bushing and adjusting nut are threaded completely into arm with no threads showing.
5. Hold the outer bushing from turning and unscrew the large 32mm adjusting nut until the arm length is approximately the same as the stock arm.
6. Install arm onto vehicle using stock bolts and tighten to manufacturers specifications. Make sure suspension is fully loaded before tightening the bushing bolts.

**Caution: While installing the arm be careful not to rotate adjuster nut or outer bushing.**

7. Install tire and wheel assembly and lower vehicle.
8. Adjust camber by turning large 32mm adjusting nut until desired camber is reached.

**Warning: The gap between the large adjusting nut and the outer end of the arm should not exceed 12.7mm (1/2"). See Fig #1. Exceeding the range of adjustment of these arms may cause the arm to fail and void warranty.**

9. Tighten small pinch bolt and nut to 20 lb-ft. Tighten jamb nut tightly against adjuster nut.
10. Adjust rear toe, recheck alignment and road test vehicle.

**Always check for proper clearance between suspension components and other components of the vehicle.**

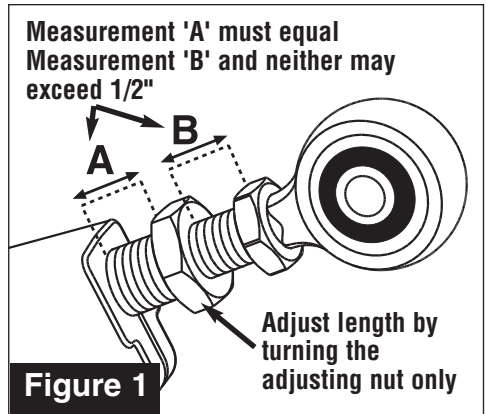

**Specialty Products Company®**

P.O. Box 923 • Longmont, CO 80502 • (303) 772-2103 • Fax: (303) 772-1918  
www.specprod.com • www.spcperformance.com • Email: info@specprod.com  
**Toll Free Technical Hot Line: 1-800-525-6505**