

RAPTOR & F150 HD CAM FRONT CAM/CAS KIT

This part should only be installed by personnel who have the necessary skill, training and tools to do the job correctly and safely. Incorrect installation can result in personal injury, vehicle damage and / or loss of vehicle control.

Plan Ahead - Read All Instructions BEFORE installing part.

Check for loose or worn parts, proper tire pressure, and odd tire wear patterns before beginning alignment.

1. Raise and support front of vehicle by lifting by frame rail to unload front suspension.
2. Remove nut from forward lower control arm bolt.
3. Using lift, adjust vehicle height so lower control arm bolt turns freely in the bracket.
4. Remove forward control arm bolt.
5. Using template carefully mark location of pilot hole on back side of the frame pocket. Pilot hole should directly line up with OEM hole on the front side of pocket.
6. Center punch pilot hole location then drill hole using an 5/16" or 8MM drill.
7. Install "D" cam then Reaction Plate on milled bolt.
8. Install bolt assembly in frame pocket through lower control arm bushing. Make sure pin in reaction bracket fits neatly into pilot hole.

Note: There are two different length bolts included with the kit. The longer bolt is installed in forward pocket.

9. Install reaction plate then "D" cam on threaded side of bolt, making sure pin in reaction bracket fits neatly into pilot hole.
10. Tighten nut lightly making sure both cams seat into their respective reaction bracket.
11. Repeat steps 4 thru 11 to replace rearward lower control arm bolt assembly.
12. Lower vehicle and adjust camber and caster.

Note: If cam bolt and washer start to bind while rotating, it may be necessary to raise vehicle by the frame to unload the suspension and start with the cam bolt positioned for the most positive camber.

13. Torque cam bolt nut to 198 lb-ft (268 N-m). Make sure suspension is loaded before tightening.
14. Adjust toe, recheck alignment and road test vehicle.

Always check for proper clearance between suspension components and other components of the vehicle.

**Specialty Products Company®**

4045 Specialty Place • Longmont, CO 80502 • (303) 772-2103 • Fax: (303) 772-1918
www.specprod.com • www.spcperformance.com • Email: info@specprod.com

Toll Free Technical Hot Line: 1-800-525-6505

ECN#2163 • Rev. 10/16

PART NO. 86252

Instruction Sheet

RAPTOR & F150 HD CAM FRONT CAM/CAS KIT

This part should only be installed by personnel who have the necessary skill, training and tools to do the job correctly and safely. Incorrect installation can result in personal injury, vehicle damage and / or loss of vehicle control.

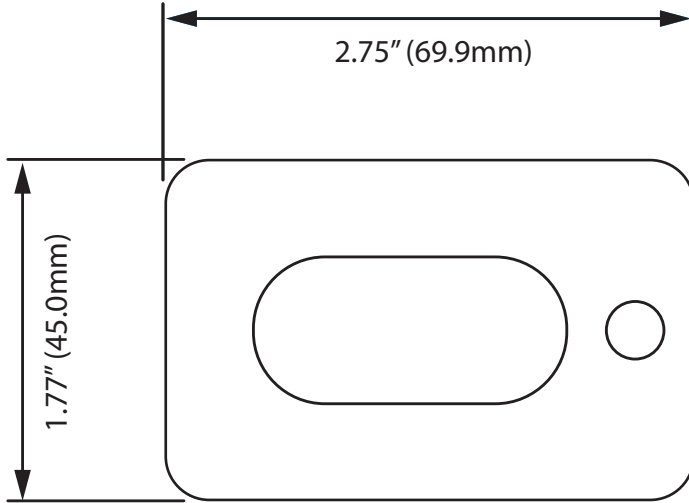

Template should be printed at 100% scale



Specialty Products Company[®]

4045 Specialty Place • Longmont, CO 80502 • (303) 772-2103 • Fax: (303) 772-1918
www.specprod.com • www.spcperformance.com • Email:info@specprod.com

Toll Free Technical Hot Line: 1-800-525-6505

ECN#2163 • Rev. 10/16

©2016 Niwot Corp. dba Specialty Products Co[®] • Printed in U.S.A. • Form No. 982521