

**ADJUSTABLE CAMBER / CASTER UPPER ARMS  
TACOMA RWD W/6 LUG AXLES / TACOMA 4WD / 4-RUNNER RWD & 4WD**

PATENT NO. US 7,513,514 B1

**This part should only be installed by personnel who have the necessary skill, training and tools to do the job correctly and safely. Incorrect installation can result in personal injury, vehicle damage and / or loss of vehicle control.**

**Plan Ahead - Read All Instructions BEFORE installing part.**

*Check for loose or worn parts, proper tire pressure, and odd tire wear patterns before beginning alignment.*

1. Raise vehicle by frame and support with jack stands. Remove front tire and wheel assembly.
2. Loosen nut on upper arm-to-frame mounting bolt and remove bolt holding ABS wiring to upper arm.
3. Remove cotter pin and nut holding OEM ball joint to upper control arm. Break taper between ball joint stud and arm, then separate ball joint from arm. (SPC Tools 37985 and 37990 work well).  
**NOTE: Support knuckle so no strain is applied to ABS wiring or brake lines.**
4. Remove nut and washer from long arm-to-frame mounting bolt and remove bolt and upper control arm.  
**NOTE: To provide clearance, additional components in engine compartment may need to be removed.**
5. Remove snap ring retaining upper ball joint into knuckle. Press out ball joint using SPC #72509 ball joint press or equivalent.
6. Press included steering knuckle insert into knuckle with flange on bottom. **See Figure 1.**
7. Install included snap ring on top side to retain insert. Be certain that snap ring is seated in groove.

8. Install SPC control arm into vehicle. Place one large offset washer on outside of each bushing as long retaining bolt is slid into place (stock washers will not be re-used). Offset should be out for clearance to bushing. **See Figure 2.** After bolt is fully seated and final washer is installed, install nut and torque to 85 lb-ft [115nm].  
**NOTE: Depending on condition of knuckle, new insert may not fit tightly into knuckle receiver. Knuckle insert will expand when ball joint stud is tightened.**  
**NOTE: Unlike OE rubber bushings, xAxis™ bushings pivot freely and may be torqued without placing any weight on suspension.**
9. Install star plate over hex on ball joint per chart below to achieve desired caster change relative to stock arm. (For most trucks with 2-3" of lift, setting "D" should return caster to factory specifications, but it may be necessary to use different positions on each side to achieve desired cross-caster setting.) Insert ball joint up through bottom of arm, indexing star plate in machined slot, and then install top washer and nut. Position in middle of slot and tighten nut for initial alignment readings.
10. Install ball joint stud into knuckle adapter, install supplied castle nut and torque to 45 lb-ft [61 Nm]. Tighten nut further only until supplied cotter pin can be installed.
11. Re-Attach ABS wiring bracket to SPC arm using factory bolt.
12. Grease ball joint with **NLGi #2, Grade LB with 3%-5% Molybdenum Disulfide grease.** 5 to 10 pumps of grease is sufficient at each lubrication.  
**WARNING: FAILURE TO GREASE AND MAINTAIN BALL JOINT MAY RESULT IN PREMATURE FAILURE.**
13. Re-install tire and wheel assembly. Lower vehicle and take alignment readings. Adjust camber by loosening top nut and sliding ball joint in control arm slot. Adjust caster by loosening top nut and repositioning star plate to rotate ball joint relative to arm. (It will be necessary to raise vehicle to make these adjustments.)

14. When final caster/camber settings are achieved, torque top ball joint nut to 150 lb-ft [203Nm]. Adjust toe, road test vehicle.

**Always check for proper clearance between suspension components and other components of vehicle.**

**Camber and caster can be set with SPC upper control arm, as well as OEM lower control arm eccentric bolts. In most cases, it is recommended that lower eccentrics be set to their neutral position. This way they can be used to fine-tune caster. Alternately, if caster is set for max positive by OEM lower cams, and final alignment achieved with SPC upper ball joint setting, more tire clearance may be obtained at rear of wheel opening.**

**Maintenance:**

*Lubrication Interval - SPC recommends adding 5 to 10 pumps of grease to ball joint at each oil change, or after operating vehicle in wet or dusty conditions.*

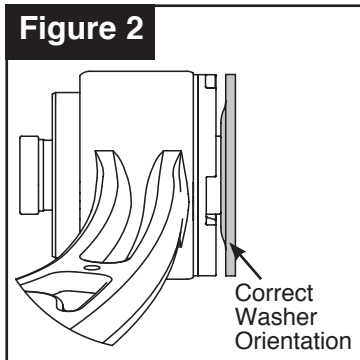
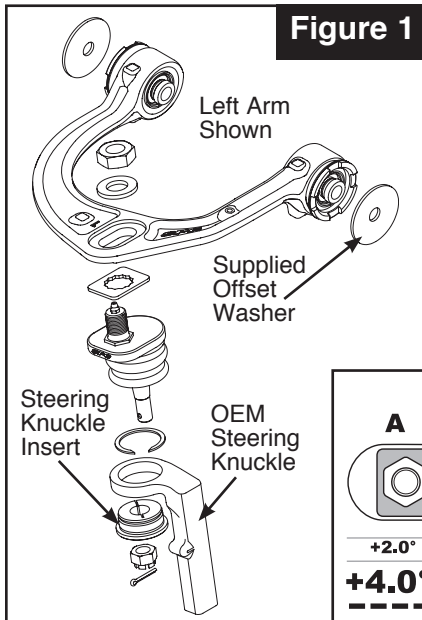

**Note: With SPC logo facing the tire (Position D) this arm will give +2° additional caster. Using the star plate, caster change can be adjusted from +0.0° to +4.0°.**

LEFT FRONT CASTER CHANGE							FRONT OF VEHICLE
A	B	C	D	E	F	G	
+2.0°	+1.75°	+1.0°	0°	-1.0°	-1.75°	-2.0°	
<b>Ball Joint Setting</b>							
<b>+4.0°</b>	<b>+3.75°</b>	<b>+3.0°</b>	<b>+2.0°</b>	<b>+1.0°</b>	<b>+0.25°</b>	<b>0.0°</b>	
<b>Total Arm + Ball Joint Caster Change</b>							
RIGHT FRONT CASTER CHANGE							FRONT OF VEHICLE
A	B	C	D	E	F	G	
+2.0°	+1.75°	+1.0°	0°	-1.0°	-1.75°	-2.0°	
<b>Ball Joint Setting</b>							
<b>+4.0°</b>	<b>+3.75°</b>	<b>+3.0°</b>	<b>+2.0°</b>	<b>+1.0°</b>	<b>+0.25°</b>	<b>0.0°</b>	
<b>Total Arm + Ball Joint Caster Change</b>							



**Specialty Products Company®**

4045 Specialty Place • Longmont, CO 80504 • (303) 772-2103 • Fax: (303) 772-1918 • www.specprod.com • Email: info@specprod.com  
Toll Free Technical Hot Line: 1-800-525-6505 • For warranty information go to: www.specprod.com/warranties