

⚠ WARNINGS & DISCLAIMERS

By installing this product you acknowledge that the suspension of this vehicle has been modified. As a result, this vehicle may handle differently than that of factory-equipped vehicles. As with any vehicle, Extreme Care must be used to prevent loss of control or roll-over during sharp turns or abrupt maneuvers. Always wear seat belts, and drive safely, recognizing that reduced speeds and specialized driving techniques may be required. Failure to drive this vehicle safely may result in serious injury or death. Do not drive this vehicle unless you are familiar with its unique handling characteristics and are confident of your ability to maintain control under all driving conditions. Some modifications (and combinations of modifications) are not recommended and may not be permitted in your state. Consult your owner's manual, the instructions accompanying this product, and state laws before undertaking these modifications. You are responsible for the legality and safety of the vehicle you modify using these components. If using ReadyAIR products in conjunction with a 5th Wheel Hitch that requires replacement of any fasteners provided by the hitch manufacturer, consulting the hitch manufacturer must be done to determine if the fastener strength provided with ReadyAIR products is acceptable for safe operation of their product. If using tire snow chains or cables with ReadyAIR products, ensure that there is adequate clearance between the tire chain and air spring assembly to avoid damage and/or failure.

Limited Lifetime Warranty

ReadyAIR provides a limited lifetime warranty to the original purchaser of its load support products, that the product be free from defects in workmanship and materials when used on cars and trucks as specified by ReadyAIR and under normal operating conditions, subject to the requirements and exclusions set forth in the full Limited Warranty and Return Policy that is available at: ReadyLIFT.com/ReadyAIR/warranty.

READYGUARD Powertrain Warranty

ReadyLIFT is proud to offer its customers a FREE powertrain warranty. The most popular line of suspension products on the market just got better with the introduction of an unprecedented 5 year - 60,000 mile Powertrain Warranty. To register please visit: ReadyLIFT.com/ready-guard

IMPORTANT INFO!

⚠ DO NOT OVERLOAD VEHICLE

This product does not increase your vehicle's maximum load capacity. Never exceed GVWR.

⚠ DO NOT OVER INFLATE

Do not exceed 150psi in the air springs.

⚠ DO NOT UNDER INFLATE

Maintain at least 10 psi in air springs when driving unloaded.

⚠ ADDING AIR

When loaded, add air until stock ride height is achieved.

⚠ CHECK TIRE CLEARANCE

Make sure that there is at least 1" clearance between the inside of tire and air spring assembly.

⚠ AVOID AIR LINE DAMAGE

Do not route air lines near hot exhaust or sharp corners.

⚠ CHECK YOUR HARDWARE

Retorque all fasteners after 500 miles.

PARTS INCLUDED

QTY	DESCRIPTION
1	DRIVER SIDE AIR SPRING ASSEMBLY
1	PASSENGER SIDE AIR SPRING ASSEMBLY
1	HARDWARE KIT
1	MANUAL INFLATION KIT
HARDWARE KIT CONTENTS	
2	M10-16MM HEX BOLT
2	JOUNCE BUMPER SPACER
1	THREADLOCKER (0.5 FL.OZ)
8	3/8"-16 4" CARRIAGE BOLT GRADE 5
8	3/8"-16 1.375" HEX BOLT GRADE 8
16	3/8"-16 NYLON LOCKING NUT GRADE 5
24	3/8" FLAT WASHER
1	1/2"-13 2" CARRIAGE BOLT GRADE 8
1	1/2" WIRE BOLT LEAD
1	RECTANGLE 1/2" CARRIAGE BOLT WASHER
3	1/2"-13 1.75" HEX BOLT GRADE 8
4	1/2"-13 NYLON LOCKING NUT GRADE 8
7	1/2" FLAT WASHER
4	FRAME HOOKS
4	AIR SPRING LOWER STRAP 3.5" CTC
1	E-BRAKE CABLE GUARD W/ CABLE TIES
MANUAL INFLATION KIT CONTENTS	
16	8" ZIP TIES
2	INFLATION VALVE TO 1/4" PTC FITTING
1	16' ROLL 1/4" AIRLINE

TOOLS REQUIRED

9/16" WRENCH & DEEP SOCKET	JACK & JACK STANDS
3/4" WRENCH & DEEP SOCKET	TORQUE WRENCH
3/8" & 1/2" DRIVE EXTENSIONS	5/16" DRILL BIT & DRILL
12 MM WRENCH (X2)	AIR LINE CUTTER (RAZOR BLADE)
SOCKET DRIVER	

⚠ ATTENTION!

If your ReadyAIR product has a damaged or missing part, please contact customer service directly and a new replacement part will be sent to you immediately. For warranty issues, please return to the place of installation and contact ReadyAIR.

INSTALLATION PROCESS

1	Note original ride height measurement from center of rear fender arch to ground.
2	Safely lift the truck and support on jack stands.
3	Remove rear wheels.
4	Unbolt factory bump stops.
5	Reinstall factory bump stops with provided aluminum spacer and longer bolt with THREADLOCKER applied to the bolt threads. Torque to 15 lb.ft
6	Fit Air Spring assemblies to frame. NOTE - If equipped with fifth wheel hitch, first remove the hitch frame mounting hardware. Use the supplied hardware to attach the upper air spring brackets to the outside of the frame or hitch through the frame mounting holes.
7	On the driver side, bend the E-brake bracket on the U-bolt saddle downward to make room for the lower bracket. Install the provided sheathing around the e-brake cable where it contacts the lower bracket.

PASSENGER SIDE

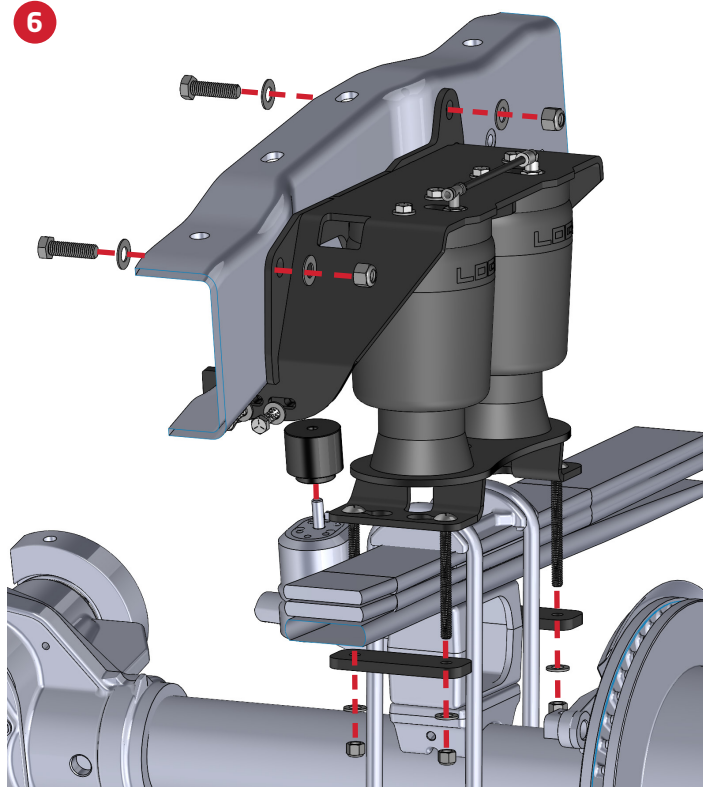

DRIVER SIDE

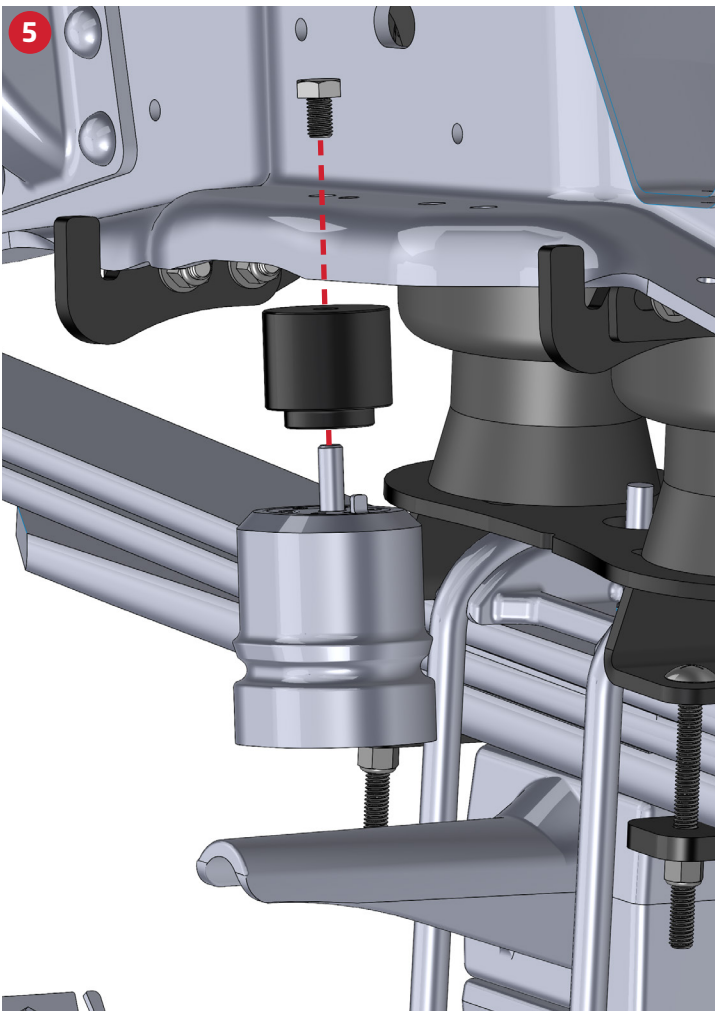
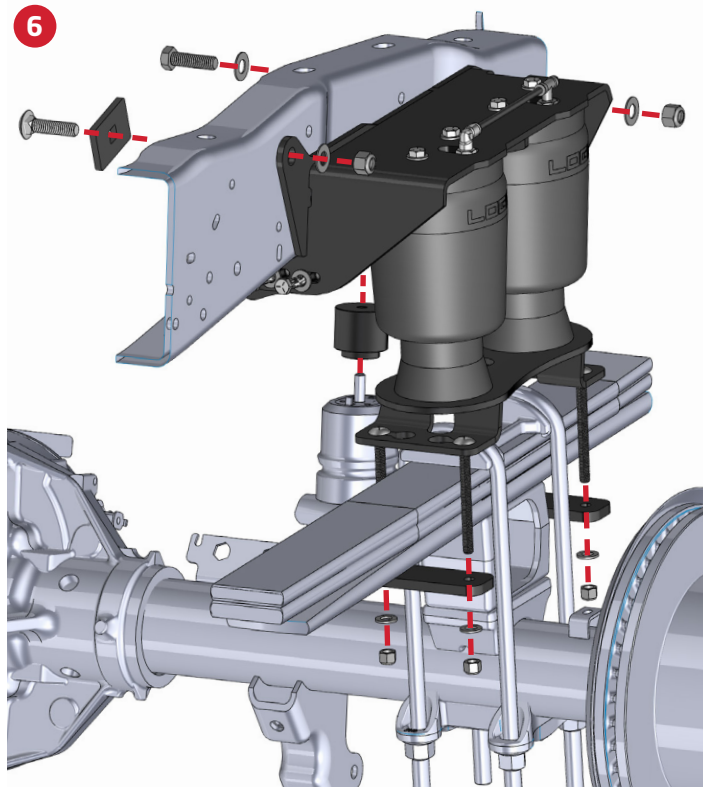

INSTALLATION PROCESS CONT'D	
8	Secure the lower bracket to the leaf spring with the supplied carriage bolts, straps, washers and nuts. Make sure the bracket is centered over the U-bolt saddle and snug the nuts.
9	For the driver side front bolt, use the supplied 1/2" carriage bolt and square washer with the wire bolt lead. Feed the bolt through the frame mounting hole above the DEF or fuel tank (depending on configuration).
10	Install all other 1/2" hardware with bolt heads on the inside of the frame. Snug the nuts.
11	Before torquing the nuts, ensure that the upper bracket legs are tight against the bottom of the frame rail. Torque 1/2" Hardware to 110 lb.ft
12	Install the frame hooks on the inside of the upper bracket with the supplied 3/8" hardware. Snug hardware then push hook tightly against the frame rail. Tap with a mallet if needed. Torque to 44 lb.ft
13	Torque all lower bracket hardware to 20 lb.ft
14	Mount inflation valves at desired location using a 5/16" drill bit.
15	Route air line from each inflation valve to each air fitting tee on both of the air spring assemblies. Avoid hot exhaust and sharp edges. Cut air line square and free from burrs with air line cutter or razor blade!
16	Final Safety Checks: <ul style="list-style-type: none"> • Check for leaks at fittings with soapy water • Check tire clearance to air spring (more than 1") • Verify all fasteners are torqued properly • Verify at least 10 psi in air springs before driving

