

*This part should only be installed by personnel who have the necessary skill, training and tools to do the job correctly and safely. Incorrect installation can result in personal injury, vehicle damage and / or loss of vehicle control.*

1. Remove old CV boot, cleaning all surfaces.
2. Pack joint with provided grease. Stretch new CV boot over joint, creating a tight fit.
3. Release any trapped air with screwdriver (**Figure 1**).
4. Using longer provided steel band install over large end of boot at original location. Use SPC Boot Clamp Installation Tool (**Part No. 02099**) to properly tighten clamp (**Figure 2**).
5. Using shorter steel band, install

over shaft end of CV joint using tool **No. 02099** to tighten (**Figure 3**).

**NOTE: If boot is properly installed it should not be stretched to fit.**

6. If the new CV boot is positioned as shown in **Figure 4** no cutting is necessary for proper fit.
7. If the new CV boot has excess material, as shown in **Figure 5**, trim excess material (**Figure 6**).

**NOTE: Small end of boot (around the shaft) should not be trimmed.**

## X-TYPE TRILOBAL INNER CV JOINTS

*If the inner CV joint looks like **Figure 7**:*

8. Cut off old CV boot, **DO NOT REMOVE THICK RUBBER BUSHING**. Remove old clamps (**Figure 8**).
9. Retain thick rubber bushing on inner CV joint (**Figure 9**).
10. Follow steps 1-5 to complete installation.

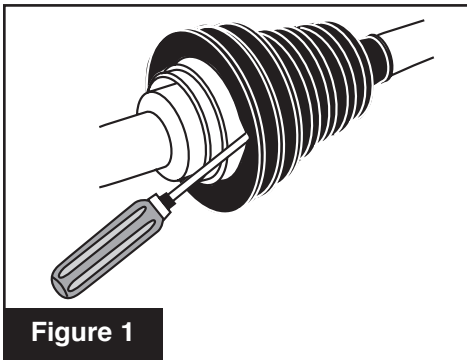

Figure 1

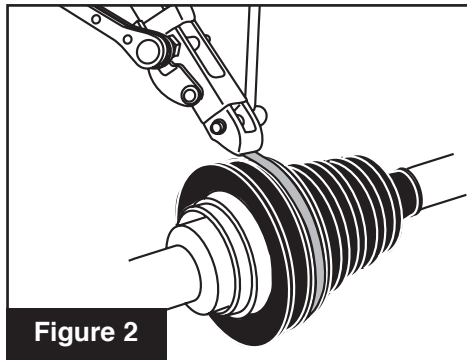

Figure 2

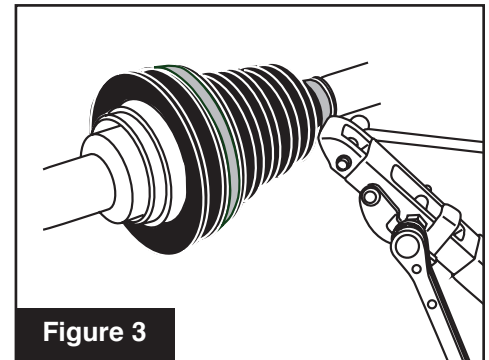

Figure 3

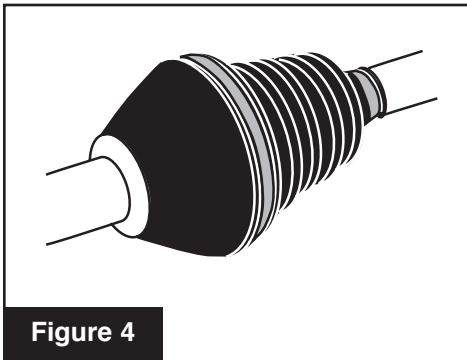

Figure 4

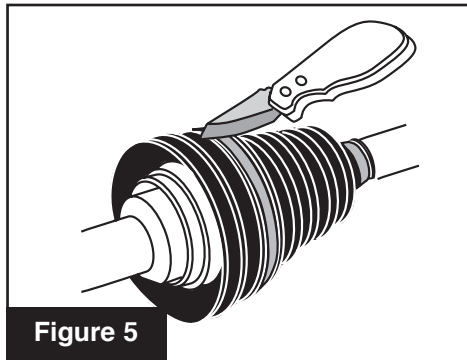

Figure 5

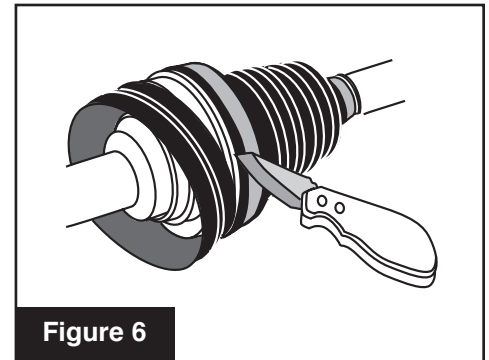

Figure 6

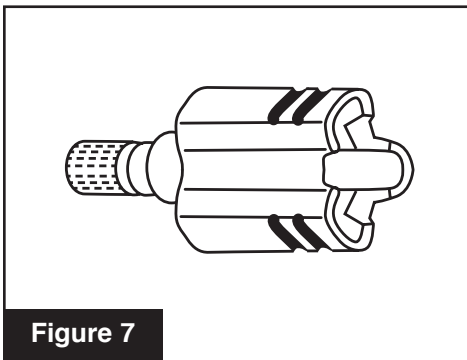

Figure 7

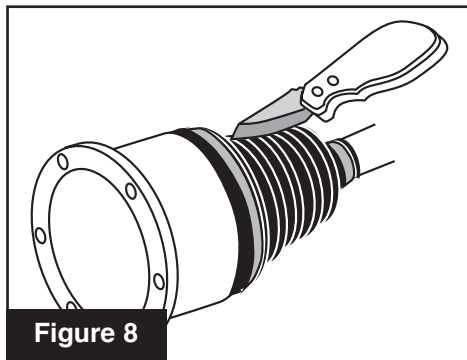

Figure 8

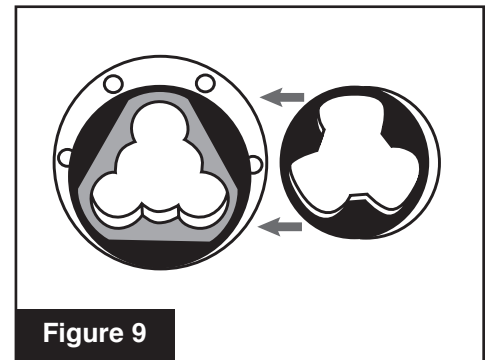

Figure 9



**Specialty Products Company®**

4045 Specialty Place • Longmont, CO 80504 • (303) 772-2103 • Fax: (303) 772-1918 • www.specprod.com • Email: info@specprod.com  
Toll Free Technical Hot Line: 1-800-525-6505 • For warranty information go to: www.specprod.com/warranties