

PART NOS. 87550 & 87555

Instruction Sheet LINCOLN/JAGUAR XAXIS™ JOINT KIT (4)

This part should only be installed by personnel who have the necessary skill, training and tools to do the job correctly and safely. Incorrect installation can result in personal injury, vehicle damage and / or loss of vehicle control.

Plan Ahead - Read All Instructions BEFORE Installing Part

1. Raise vehicle and support by frame.
2. Remove rear tire and wheel assembly.
3. Remove lower control arm per manufacturer's procedure.
4. Note depth to which each OE joint is pressed into its receiver ring by measuring from outer face of joint (**A**) to corresponding receiver ring face (**B**). (Ensure joint face is parallel to receiver ring face when measuring - *Figure 1*).

NOTE - ON FORD/LINCOLN APPS ONLY: One joint is wider than the other. Note location of wider joint.

5. Press out OE joints using supplied press tools.

NOTE: Press joints by outer housing only.

6. Press in SPC xAxis joints to depths recorded in Step 4. Ensure that wider SPC xAxis joint is installed in location of wider OE joint.
7. Reinstall lower control arm per manufacturer's procedure and loosely install mounting hardware.
NOTE: Tightening fasteners with vehicle in raised position may cause premature bushing failure.
8. Reinstall tire and wheel assembly and lower vehicle.
9. Torque fasteners to manufacturer's specification.

Always check for proper clearance between suspension components and other components of the vehicle.

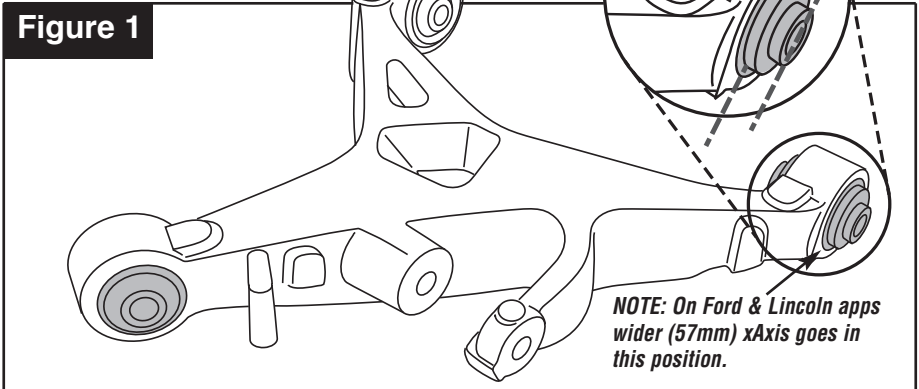

Specialty Products Company®

P.O. Box 923 • Longmont, CO 80502 • (303) 772-2103 • Fax: (303) 772-1918

www.specprod.com • www.spcperformance.com • Email: info@specprod.com

Toll Free Technical Hot Line: 1-800-525-6505

ECN#2054

©2016 Niwot Corp. dba Specialty Products Co • Printed in U.S.A. • Form No. 985502 • Rev. 1/16