

# PART NO. 35101

## Instruction Sheet ADJUSTABLE BALL JOINT REPLACEMENT

*This part should only be installed by personnel who have the necessary skill, training and tools to do the job correctly and safely. Incorrect installation can result in personal injury, vehicle damage and / or loss of vehicle control.*

**Plan Ahead - Read All Instructions BEFORE installing part.**

**Check for loose or worn parts, proper tire pressure, and odd tire wear patterns before beginning replacement.**

1. Raise vehicle and support by frame.
2. Remove front tire and wheel assembly.
3. Remove cotter pin and castle nut. Use Specialty Products Part #37985 or equivalent ball joint separator to break taper between ball joint and insert, using caution not to damage ball joint threads.

**Warning: If knuckle has a knuckle insert installed and it is not black in color, it should be replaced before using this ball joint. See Part #35108.**

4. Using a marker, trace washer on top of arm to mark its location. Also mark body of ball joint and star plate, ensuring markings overlap with each other.

**NOTE: These markings will be used to maintain vehicle alignment when installing new ball joint.**

5. Remove top nut and remove ball joint from control arm, maintaining star plate and ball joint orientation. If orientation is lost, use markings made in step 4 to reset star plate in original position.
6. Clock star plate on new ball joint to match orientation of star plate on removed ball joint.
7. Install new ball joint as shown in **Figure 1** and loosely install washer and top nut.
8. Slide ball joint so washer aligns with circle traced in step 4.
9. Torque top nut to **200 ft-lbs [271 N-m]**.

**NOTE: Ensure top washer remains within perimeter traced in step 4 after top nut is tightened.**

10. Insert ball joint stud into knuckle, torque castle nut to 45ftlb [61Nm], and then tighten further until cotter pin can be installed.
11. Reinstall front tire and wheel assembly, lower vehicle, and road test.

**Always check for proper clearance between suspension components and other components of the vehicle.**

### Maintenance:

**This ball joint is fully sealed and features a lifetime grease. No maintenance is required after installation.**

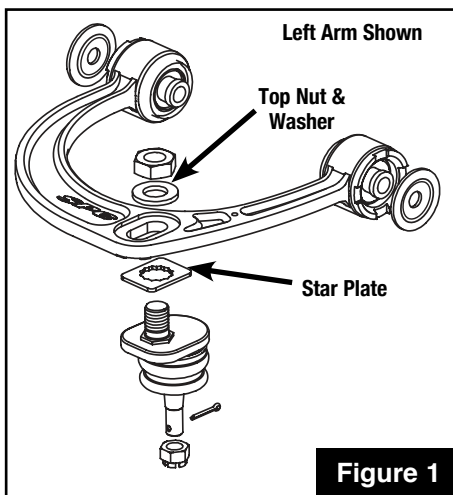

**Specialty Products Company®**

4045 Specialty Pl. • Longmont, CO 80504 • (303) 772-2103 • Fax: (303) 772-1918  
**Toll Free Technical Hot Line: 1-800-525-6505** • www.specprod.com ECN#3554  
For warranty information go to: [www.specprod.com/warranties](http://www.specprod.com/warranties) • Email: [info@specprod.com](mailto:info@specprod.com)

©2024 Specialty Products Company® • Printed in U.S.A. • Form No. 35101INS • Rev. A