

INSTALLATION GUIDE

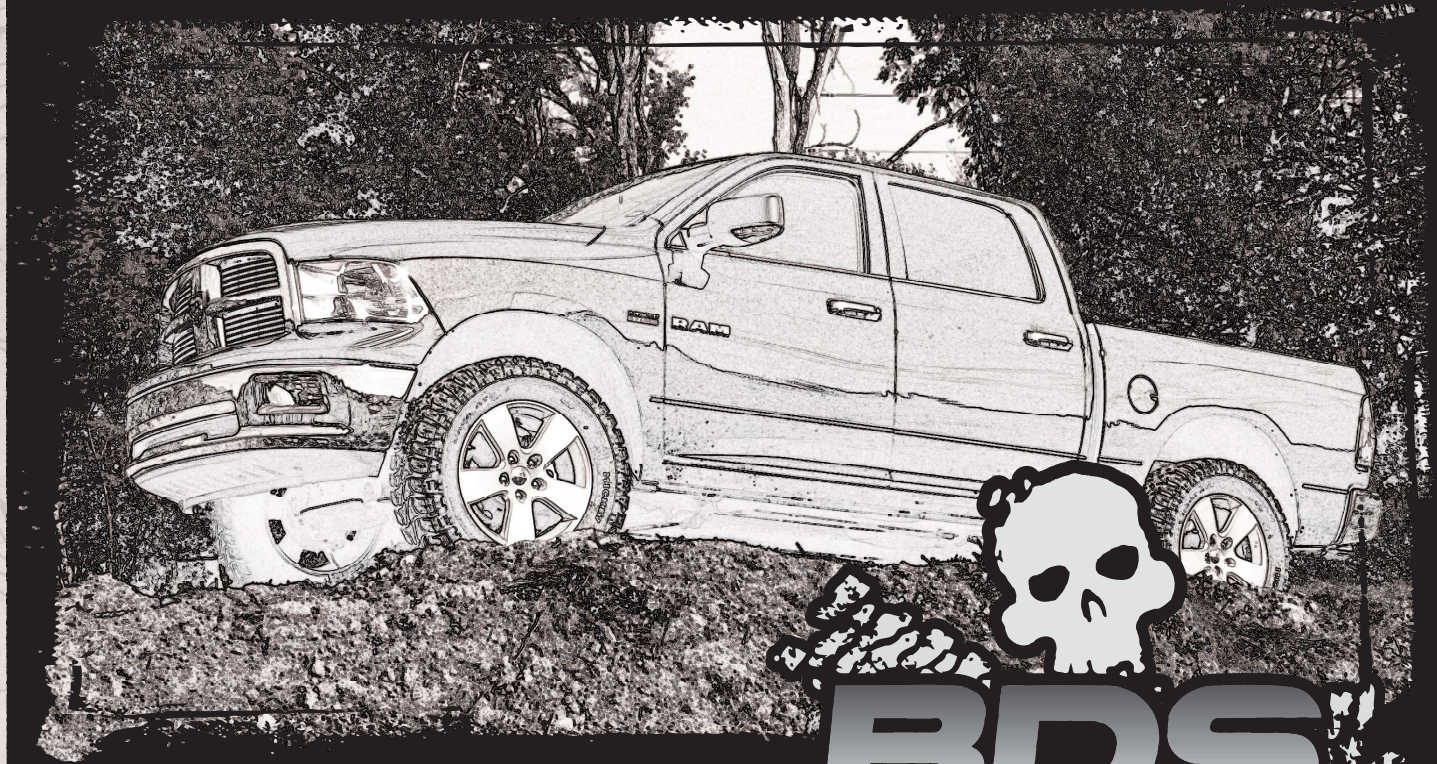

Part#: 022309, 022509, 022209



HARDCORE LIMITED LIFETIME WARRANTY

Rear High Clearance Suspension System

Dodge 1500 4WD | 2009-2018

Rev. 021523

491 W. Garfield Ave., Coldwater, MI 49036 • Phone: 517-279-2135

E-mail: tech@ridefox.com

Read And Understand All Instructions And Warnings Prior To Installation Of System And Operation Of Vehicle.

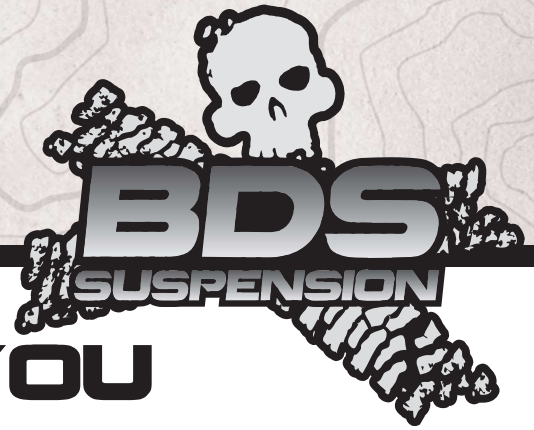

THANK YOU

Your truck is about to be fitted with the best suspension system on the market today. That means you will be driving the baddest looking truck in the neighborhood, and you'll have the warranty to ensure that it stays that way for years to come. Thank you for choosing BDS Suspension!

BEFORE YOU START

BDS Suspension Co. recommends this system be installed by a professional technician. In addition to these instructions, professional knowledge of disassembly/ reassembly procedures and post installation checks must be known.

FOR YOUR SAFETY

Certain BDS Suspension products are intended to improve off-road performance. Modifying your vehicle for off-road use may result in the vehicle handling differently than a factory equipped vehicle. Extreme care must be used to prevent loss of control or vehicle rollover. Failure to drive your modified vehicle safely may result in serious injury or death. BDS Suspension Co. does not recommend the combined use of suspension lifts, body lifts, or other lifting devices. You should never operate your modified vehicle under the influence of alcohol or drugs. Always drive your modified vehicle at reduced speeds to ensure your ability to control your vehicle under all driving conditions. Always wear your seat belt.

BEFORE INSTALLATION

Special literature required: OE Service Manual for model/year of vehicle. Refer to manual for proper disassembly/reassembly procedures of OE and related components.

Adhere to recommendations when replacement fasteners, retainers and keepers are called out in the OE manual.

Larger rim and tire combinations may increase leverage on suspension, steering, and related components. When selecting combinations larger than OE, consider the additional stress you could be inducing on the OE and related components.

Post suspension system vehicles may experience drive line vibrations. Angles may require tuning, slider on shaft may require replacement, shafts may need to be lengthened or trued, and U-joints may need to be replaced.

Secure and properly block vehicle prior to installation of BDS Suspension components. Always wear safety glasses when using power tools.

If installation is to be performed without a hoist, BDS Suspension Co. recommends rear alterations first.

Due to payload options and initial ride height variances, the amount of lift is a base figure. Final ride height dimensions may vary in accordance to original vehicle attitude. Always measure the attitude prior to beginning installation.



Visit 560plus.com for more information.

TRACTION CONTROL

In an effort to reduce the risk of rollover crashes the National Highway Traffic Safety Administration (NHTSA) established the Federal Motor Vehicle Safety Standard (FMVSS) No. 126 requiring all new passenger vehicles under 10,000 lbs GVWR include an electronic stability control (ESC) system as standard equipment. Effective August 2012 this law requires aftermarket products to be compliant with these same standards.



BEFORE YOU DRIVE

Check all fasteners for proper torque. Check to ensure for adequate clearance between all rotating, mobile, fixed, and heated members. Verify clearance between exhaust and brake lines, fuel lines, fuel tank, floor boards and wiring harness. Check steering gear for clearance. Test and inspect brake system.

Perform steering sweep to ensure front brake hoses have adequate slack and do not contact any rotating, mobile or heated members. Inspect rear brake hoses at full extension for adequate slack. Failure to perform hose check/ replacement may result in component failure. Longer replacement hoses, if needed can be purchased from a local parts supplier.

Perform head light check and adjustment.

Re-torque all fasteners after 500 miles. Always inspect fasteners and components during routine servicing.

CONTENTS OF YOUR KIT

BDS022209, BDS022309, & BDS022509 Box Kits		
<i>Part #</i>	<i>Qty</i>	<i>Description</i>
01278	2	Preload Spacer
02280B	1	Rear Track Bar Bracket
03574	1	Driver Rear Bump Spacer
03575	1	Passenger Rear Bump Spacer
01292	1	Driver Side Relocation Bracket
01293	1	Passenger Side Relocation Bracket
911112	2	Sway bar links (022509 Only)
911103	2	Sway bar link (022309 & 022209 Only)
01290	2	Shock Nut Tab
01294	2	Nut Plate
01894	2	Upper Coil Retainer (022309 Only)
109	1	1.00 x .125 x 1.360 DOM Sleeve
110	2	1.00 x .125 x 2.375 DOM Sleeve
62147	4	.625 x .075 x 1.375 Sleeve
SB58BK	4	5/8 ID Hourglass Bushing - black
SBLA	2	Brake Adapters
01999B	2	Rear Bump Stop (022509 Only)
03574	1	Driver Rear Bump Spacer (022309 & 022209 Only)
03575	1	Passenger Rear Bump Spacer (022309 & 022209 Only)
032509R	2	5" Rear Coil (022509 Only)
032309R	2	3" Rear Coil (022309 Only)
02533BK	2	2" Rear Coil Spacer (022209 Only)

Bolt Packs		
<i>Part #</i>	<i>Qty</i>	<i>Description</i>
807	1	Bolt Pack - Sway Bar Links
	4	12mm x 60mm bolt
	8	7/16" USS washer
	4	12mm Prevailing torque nut
477	1	Bolt Pack - Rear Bump Stops (022309 & 022209 Only)
	4	3/8-16 X 3/4" SHCS, Clear Zinc
813	1	Bolt pack - Main Rear Kit
	3	9/16" x 3" bolt
	1	9/16" Prevailing torque nut
	4	9/16" SAE washer
	2	5/8" x 4-1/2" bolt
	2	5/8" Prevailing torque nut
	4	5/8" SAE washer
	9	3/8" x 1-1/4" Bolt
	9	3/8" Prevailing torque nut
	18	3/8" SAE T washer
	1	8mm x 30mm bolt
	1	5/16" USS washer
	2	1/4" x 3/4" bolt
	2	1/4" nylock nut
	4	1/4" SAE washer
599	1	Bolt Pack - Coil Spring Retainer (022309 Only)
	2	3/8"-16 x 1-1/4" Bolt - type 23 Self threading
	2	3/8"-16 x 2" Bolt, Grade 5, Clear Zinc
	2	3/8"-16 x 1" Bolt, Grade 5, Clear Zinc
	2	3/8"-16 Serrated Edge Flanged Nut, Clear Zinc
	4	3/8" USS Washer, Clear Zinc
808	1	Bolt Pack - Rear Bump Stops (022509 Only)
	4	3/8"-16 x 7/8" Bolt, Grade 8, Yellow Zinc
	4	3/8" SAE Washer, Yellow Zinc

TROUBLESHOOTING INFORMATION FOR YOUR VEHICLE

1. These trucks vary from 1-3" tail high from the factory. Measure your vehicle before installing. The 022209, 022309, and 022509 can all be substituted to achieve the desired stance.
2. Will not fit adjustable air suspension equipped models.

INSTALLATION INSTRUCTIONS

PRE-INSTALLATION MEASUREMENTS

Measure from the center of the wheel up to the bottom edge of the wheel opening

LF _____ RF _____ LR _____ RR _____

INSTALLATION INSTRUCTIONS

1. Park the vehicle on clean, flat, and level surface. Block the front wheels for safety.
2. Disconnect the rear trackbar from the axle, retain hardware.
3. Raise the rear of the vehicle and support the frame rails with jackstands.
4. Remove the wheels.
5. Support the axle with a hydraulic jack.
6. Remove the OE shocks. Retain the mounting hardware.
7. Remove the parking brake cable retaining the ring from the driver's side frame rail (Fig 1). Remove the driver's side parking brake cable from the ring and reinstall the ring on the frame with the passenger's side cable still in it.

**Tip**

Newer models this step is not necessary because the cable bracket is connected to the control arm instead of the frame.

FIGURE 1



8. Disconnect brake line brackets from the outside of the frame rails. Remove the ABS wires from the retaining clips. (Fig. 2)

FIGURE 2



9. Remove rear sway bar links.
10. Lower the rear axle and remove the coils, retain the rubber isolators.
11. Disconnect the upper control arm from the axle. Loosen the upper control arm bolt at the frame rail, but do not remove. Retain hardware.
12. Place the upper control arm relocation bracket over the pocket. The plate will be offset towards the inside of the vehicle. The upper plate will only use 2 of the 4 holes that go from the top down. Mark the center of the holes and drill to 7/16". (Fig 3 - pass side, Fig. 4a, b – drv side)

FIGURE 3

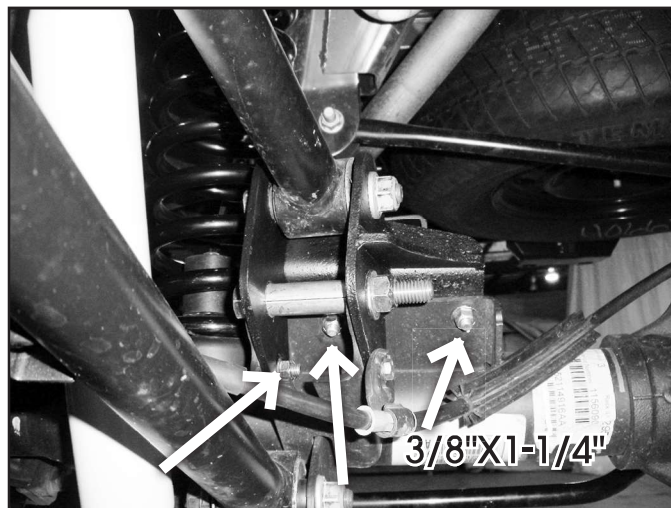

FIGURE 4A

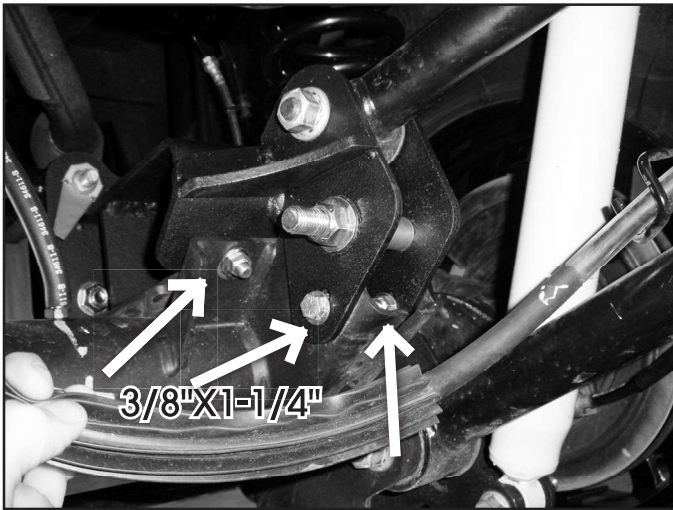
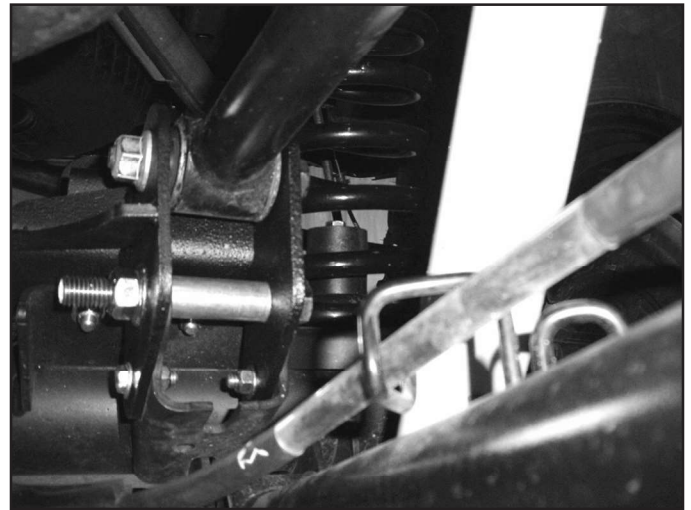

FIGURE 4B



13. The lower holes can be marked by offsetting the plate to the opposite side of the control arm pocket, or cutting out the template at the end of the instruction sheet, aligning it with the bracket profile, and translating the hole onto the frame bracket. Mark the lower hole centers and drill out to 3/8 to 7/16".
14. Attach relocation brackets with 3/8" x 1-1/4" bolts, washers, and nuts. The inside passenger hole will require the 8mm bolt and the tab on the e-brake cable bracket to be formed slightly for clearance. Use 5/8" x 4-1/2" bolt with crush sleeve through the original upper arm mounting hole. Hardware is located in bolt pack 813.
15. Install the upper arm with the OE bolt. Leave control arm hardware loose at this time. Tighten 8mm bolt to 25 ft-lbs, 3/8" hardware to 35 ft-lbs, and 5/8" hardware to 95 ft-lbs.
16. 3" rear coil kit only: Drill the center of the lower coil mounting seat to 5/16" ~ 21/64" and tap the hole to 3/8" with the included self threading bolt (#599).
17. Lower the axle and install the new coil springs with OE rubber isolator. If installing optional kit with 2" spacers, place spacers against the frame with the OE isolator below (Fig 5a). Reinstall the coil assembly with spacer as shown (either new coil or coil and spacer). 3" rear kit only: Attach the coil to the upper frame mount with the provided coil retaining clip (#01894) through the factory hole and through the coil to keep it secured to frame. The hole is located towards the rear of the vehicle. Attach upper mount with 3/8" x 1-1/4" hardware (Fig 5b), attach lower coil centering block to the axle with 3/8" x 2" bolt with washer (Bolt Pack #599). (Fig 5c)

FIGURE 5A



18. Install the new rear shocks. Use new 9/16" x 3" bolts at the top mount with the new nut tabs (01290). Tighten shock hardware to 75 ft-lbs.
19. Place rear track bar bracket (02280B) over original mount. Mark hole center to be drilled. Remove bracket and drill hole to 7/16".
20. Install the track bar bracket back on the factory mount. Fasten with the provided 9/16" hardware through the original track bar hole. Place the provided crush sleeve (109) in the factory bracket when installing the hardware (Fig 6a). Attach bracket with 3/8" x 1-1/4" bolt, nuts and washers through the hole drilled in the previous step. Tighten 3/8" hardware to 35 ft-lbs and 9/16" to 95 ft-lbs. (Fig 6b)

FIGURE 5B

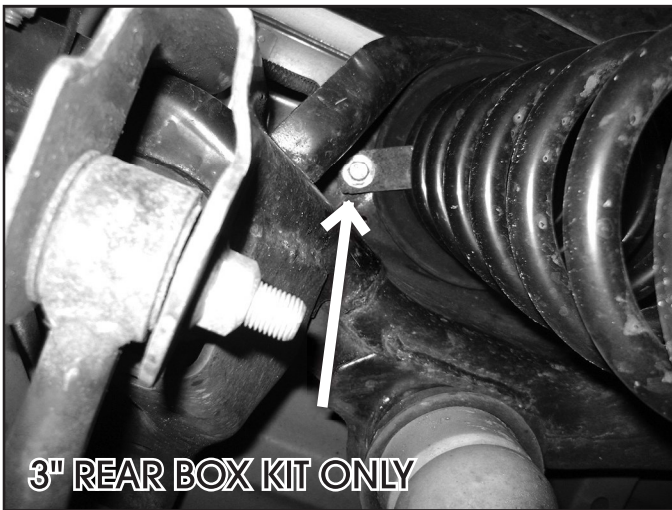

FIGURE 5C



FIGURE 6A

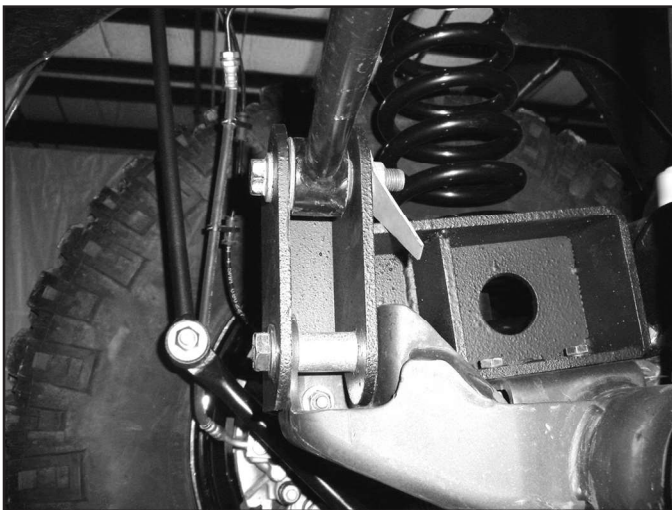
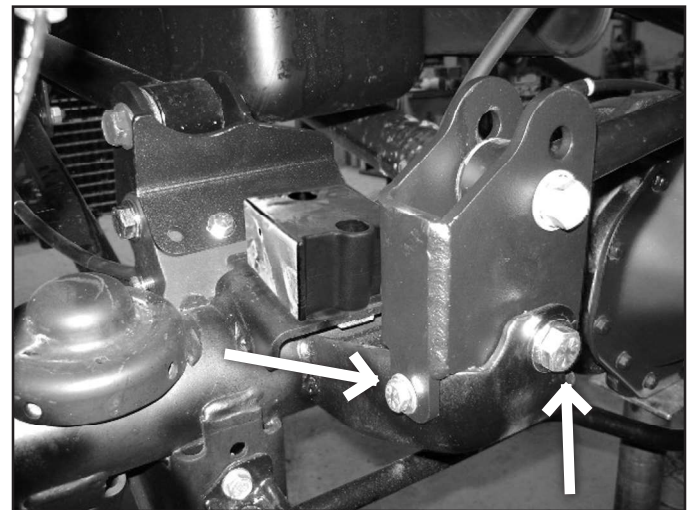
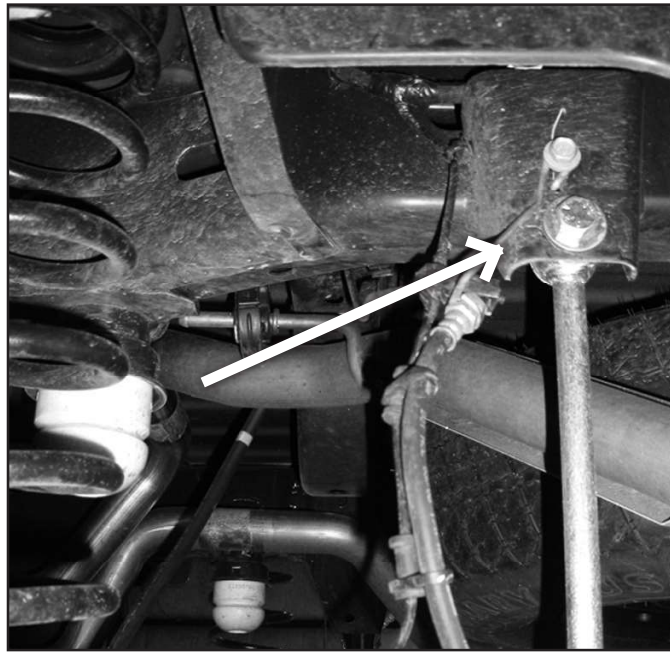

FIGURE 6B



21. Attach bump stop extensions (01999 - 5in kit / 03574, 03575 2-3in kit) to driver's and passengers's side with 3/8" x 7/8" bolts with washers (BP 808) into the provided threaded plates (01294). Tighten to 35 ft-lbs. 2-3" rear kits orientate the block so that it is the short (2") setup (Fig 6b). When installing the 5in system, install the extension with the offset going forward.
22. Install hourglass bushings into sway bar links. Install sleeves into bushings.
23. Install sway bar links (15" long - #91112 - 5 inch kit / 13" long - #911103 - 3 & 2 inch kit) on vehicle with 12mm x 60mm bolts, washers and nuts. (#807) Tighten to 55 ft-lbs. (Fig 8). Sway bar links mount to the inside of the bracket, same as the factory sway bar links.

FIGURE 7



24. Install brakeline drop brackets on the side of the frame rail. Attach brakeline to bracket with $\frac{1}{4}$ " x $\frac{3}{4}$ " bolt, washers, and nut. Tighten to 20 ft-lbs. (Fig 9)

FIGURE 8



25. Reattach ABS wire to clips on brakeline.
26. Install wheels and lower vehicle to the ground.
27. Tighten upper control arm hardware to 120 ft-lbs.
28. Install rear trackbar into relocation bracket with OE bolt and nut. Tighten to 95 ft-lbs.
 - 5 inch rear lifts (022509) use the upper hole.
 - 2-3 inch rear lifts (022209/022309) use the lower hole.
29. Recheck all fasteners for proper torque. Check again after 500 miles and at regularly scheduled intervals.

Rear Template 09+ Dodge 1500

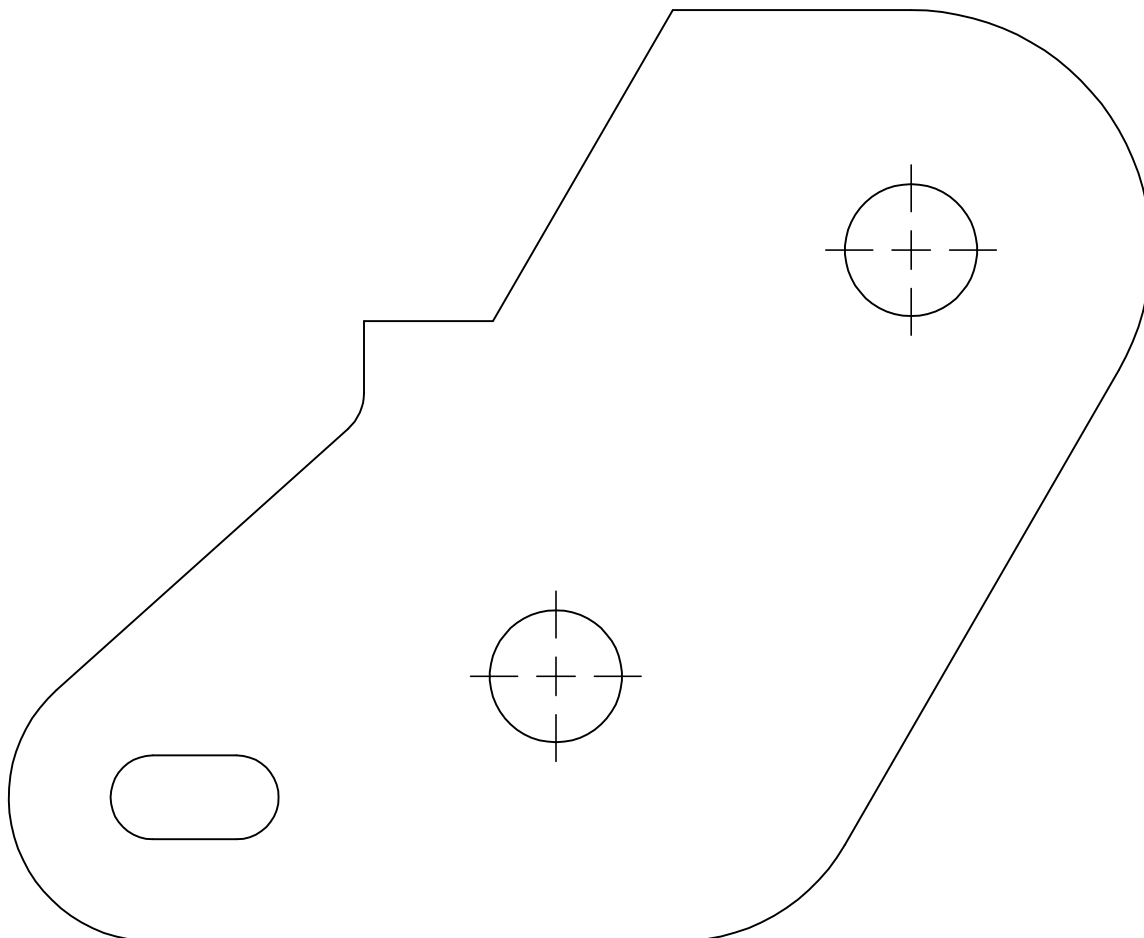

WE WANT TO SEE YOUR RIDE!

Grab photos of your BDS-equipped truck in action and send them in for a chance to be featured. Send it in to our Bad Ass Rides customer gallery at bds-suspension.com/bar and post them on the BDS Fan Page on Facebook at facebook.com/BDSSuspensions. Don't forget about your BDS swag! BDS offers t-shirts, hoodies, decals and more available on the BDS website or through your local BDS distributor.

TIME TO HAVE SOME FUN

Thank you for choosing BDS Suspension.

For questions, technical support and warranty issues relating to this BDS Suspension product, please contact your distributor/installer before contacting BDS Suspension directly.