



**65C COMPRESSOR KIT 12V
P/N 00065**

IMPORTANT:

It is essential that you and any other operator of this product read and understand the contents of this manual before installing and using this product.

SAVE THIS MANUAL FOR FUTURE REFERENCE

65C Air Compressor Kit

IMPORTANT SAFETY INSTRUCTIONS

CAUTION - To reduce risk of electrical shock or electrocution:

- Do not disassemble. Do not attempt repairs or modifications. Refer to qualified service agencies for all service and repairs.
- Do not use this product in an area where it can fall or be pulled into water or other liquid.
- Do not reach for this product if it has fallen into liquid.
- Use this compressor with 12-Volt DC systems only.
- This product should never be left unattended during use.

WARNING - To prevent injury:

- Never allow children to operate this compressor. Close supervision is necessary when this compressor is being used near children.
- This compressor will become very HOT during and immediately after use. Do not touch any part of this compressor with bare hands, other than the ON/OFF switch, during and immediately after use.
- Do not use this product near flames or explosive materials or where aerosol products are being used.
- Do not operate this product where oxygen is being administered.
- Do not pump anything other than atmospheric air.
- Never use this product while sleepy or drowsy.
- Do not use any tools or attachments without first determining maximum air pressure for that tool or attachment.
- Never point any air nozzle or air sprayer toward another person or any part of the body.
- Wear safety glasses or goggles when operating this product.
- Use only in well ventilated areas.

INSTALLATION

Please read and follow the installation instructions carefully to avoid injury or damage to the compressor and your vehicle. Each of our air compressors and parts have been carefully produced and packaged. Before you begin installation, please familiarize yourself with Installation Parts List (Fig. 1) of this manual.

Selecting a Mounting Location:

The selection of proper mounting location for your air compressor will help ensure a long and trouble free compressor service life. Please pay close attention to the following guidelines:

1. Select a FLAT, UPRIGHT AND SECURE location where the compressor can be mounted.
2. To maximize air compressor performance, locate compressor as CLOSE TO THE BATTERY as possible so that length of positive lead wire required is at a minimum.
3. Choose mounting location that is as cool as possible and AWAY FROM HEAT SOURCES. The cooler the ambient temperature the less chance the compressor will overheat.
4. This compressor is moisture & splash resistant, but NOT WATER OR DUST PROOF. Do not mount compressor in locations where the unit is likely to come in contact with water.
5. If it is necessary to mount the air compressor further away from the battery, such as inside your vehicle or in the bed of your pickup, use a minimum 16 AWG positive lead wire for remote installation. (See wire gauge reference chart)
6. Do not mount compressor near areas where flammable liquids are stored.

65C Air Compressor Kit

MOUNTING AND WIRING

1. Disconnect Temporarily ground position cable the from vehicle's battery.
2. Temporarily position the air compressor in the location where it will be mounted.
3. Route ground wire to the negative post of the battery or to an appropriate grounding point and cut ground wire to length as needed.
4. Mount air compressor with the four sets of 0.15" (4mm) bolt, nuts, washers, and locking washers and rubber washers provided. (See Fig. 1 for Mounting Instructions) Use of thread sealant recommended.
5. Connect compressor's positive lead wire to one of the leads of your pressure switch.
6. Make sure that your compressor setup is properly fused. For appropriate fuse size, refer to-Amp draw of compressor in the specifications section of this manual.
7. Always locate fuse as close as possible to power source.
8. Before connecting to power source, re-check to make sure a that all connections are properly connected.
9. Connect and test compressor system by running the compressor for a short time to build up pressure in your air tank.
10. Once air pressure reaches preset cut out pressure of your pressure switch, the compressor will shut off. Inspect all air line connections for leaks with soap and water solution. If a leak is detected, the air line may not be cut squarely or pushed all the way in. Fix air fitting connections as needed.

(Fig. 2) Compressor Mounting Hardware

- B. Mounting Bolts
- C. Flat Washer
- D. Locking Washer
- E. Nut
- K. Rubber Washer

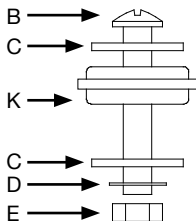

65C Air Compressor Kit

OPERATING INSTRUCTIONS

1. **IMPORTANT:** Always operate the compressor at or below the MAXIMUM PRESSURE RATING of the compressor. Please refer to Application & Specifications Sections of this manual for details.
2. Always observe the MAXIMUM DUTY CYCLE of the air compressor. Refer to Compressor Applications and Specifications Sections of this manual for details. Operation exceeding maximum pressure ratings and/or duty cycle will result in damage to the air compressor.
3. To prevent discharge of your vehicle's battery, we strongly recommend that you keep the vehicle's engine running while using the air compressor. **ONLY OPERATE THE AIR COMPRESSOR IN WELL-VENTILATED AREAS.** Compressor performance is also enhanced when operating compressor with vehicle's engine running.

MAINTENANCE & REPAIRS

1. Periodically check all electrical and fitting connections. Clean and tighten as needed.
2. Periodically check all mounting screws. Tighten as needed.
3. Regularly clean dust and dirt from compressor cooling fins and motor housing.
4. Your air compressor is equipped with permanently lubricated, maintenance-free motor. Never try to lubricate compressor.
5. All repairs should be performed by Manufacturer or Manufacturer's Authorized Service Agencies only.

CAUTION:

Never touch the air compressor or fittings connected to the air compressor with bare hands during or immediately after use. The compressor will become very hot during and after use. If necessary, wear heat resistant gloves.

PLEASE NOTE:

Use thread sealant for proper installation. Thread tape is not recommended. Properly sealed, recommended torque for 1/8" NPT fittings is 10 to 11ft. lbs.

SPECIFICATIONS

- Part No. 00065 / 65C 12V Air Compressor

Motor Voltage:	12-Volts
Max. Current Consumption:	10-Amps
Recommended Fuse:	15-Amps
Motor Type:	Permanent Magnetic
Max. Working Pressure:	90 PSI*
Max. Duty Cycle (@ 72°F & 100 PSI):	15%
Max. Ambient Temperature:	140°F
Min. Ambient Temperature:	-4°F
Ingress Protection Rating:	IP54

* Do not exceed compressor's max working pressure to prevent damage to the compressor.

65C Air Compressor Kit

TROUBLESHOOTING GUIDE:

Compressor will not run	<ol style="list-style-type: none">1. No power, or power switch in OFF position2. Blown fuse3. Faulty pressure switch (if hooked up to a pressure switch).	<ol style="list-style-type: none">1. Make sure compressor switch is ON2. Disconnect compressor from power source, replace fuse. (Refer to Specifications section for correct fuse-Amperage)3. Replace pressure switch
Excessive knocking or rattling	<ol style="list-style-type: none">1. Loose mounting bolts2. Worn bearing on eccentric or motor shaft3. Cylinder or piston ring is worn	<ol style="list-style-type: none">1. Tighten bolts2. Replace bearing or piston assembly3. Replace piston or compressor
Tank pressure drops when compressor(s) shut off	<ol style="list-style-type: none">1. Loose drain cock2. Check valve leaking3. Loose connections	<ol style="list-style-type: none">1. Tighten drain cock2. Replace check valve or compressor3. Check all connections with soap and water solution and tighten
Compressor runs continuously and air flow lower than normal	<ol style="list-style-type: none">1. Excessive air usage2. Loose connections3. Worn piston ring or inlet valve.4. Clogged air filter element	<ol style="list-style-type: none">1. Decrease air usage2. Check all connections with soap and water solution and tighten.3. Replace compressor4. Replace air filter element
Compressor runs continuously causing safety valve (if equipped) to open	<ol style="list-style-type: none">1. Faulty pressure switch2. Defective safety valve	<ol style="list-style-type: none">1. Replace pressure switch2. Replace safety valve
Excessive moisture in discharge	<ol style="list-style-type: none">1. Excessive water in air tank2. High humidity	<ol style="list-style-type: none">1. Drain tank, tilt tank to drain. Drain tank more frequently2. Move compressor to area with less humidity, or use water separator

CAUTION:

NEVER DISASSEMBLE COMPRESSOR WHILE COMPRESSOR IS PRESSURIZED.

65C Air Compressor Kit

COMPRESSOR APPLICATION GUIDE

To ensure that you get the highest level of satisfaction from your compressor performance, refer to information below:

VIAIR® COMPRESSOR REFERENCE CHART

COMPRESSOR SERIES	MAX. WORKING PRESSURE	DUTY CYCLE (100 PSI @ 72°F)
065 SERIES	80 PSI	15%
090 SERIES	120 PSI	9%
092 SERIES	120 PSI	9%
095 SERIES	120 PSI	9%
097 SERIES	130 PSI	10%
098 SERIES	130 PSI	10%
100 SERIES	130 PSI	15%
250 IG SERIES	150 PSI	100%
275 SERIES	150 PSI	25%
280 SERIES	150 PSI	30%
325 SERIES	150 PSI	33%
330 IG SERIES	150 PSI	100%
350 SERIES	150 PSI	100%
380 SERIES	200 PSI	100%
400 SERIES	150 PSI	55% @ 200 PSI 33%
420 SERIES	150 PSI	33%
425 SERIES	175 PSI	33% @ 175 PSI 50%
444 SERIES	200 PSI	100% 50% @ 200 PSI
450 SERIES	150 PSI	100%
450 IG SERIES	150 PSI	100%
460 SERIES	150 PSI	100%
480 SERIES	200 PSI	100% 50% @ 200 PSI
485 SERIES	200 PSI	100% 100% @ 200 PSI

ABOUT COMPRESSOR DUTY CYCLE:

Duty cycle refers to the amount of time a compressor can be operated in a given time period at 100 PSI, and a standard ambient temperature of 72° F. It is commonly expressed in percentage format: $\text{Compressor on time} \div (\text{on time} + \text{off time}) = \text{Duty Cycle}\%$.

ONE-HOUR DUTY CYCLE

(100 PSI @ 72°F)

	MINUTES ON / MINUTES OFF
9%	5 min. On / 55 min. Off
10%	6 min. On / 54 min. Off
15%	9 min. On / 51 min. Off
20%	12 min. On / 48 min. Off
25%	15 min. On / 45 min. Off
30%	18 min. On / 42 min. Off
33%	20 min. On / 40 min. Off
50%	30 min. On / 30 min. Off
100%	1 Hour Run Time

NOTE: All compressors, regardless of rated duty cycle, require sufficient rest time in between cycles to allow for partial or complete heat dissipation. Heat dissipation rates may vary depending on ambient temperatures and operating conditions.

ABOUT RATED WORKING PRESSURE:

To ensure trouble free service life of your compressor, always operate compressor within rated working pressure of the compressor. Never use a pressure switch with a higher cut-off pressure than compressor's rated working pressure.

THIS PAGE INTENTIONALLY LEFT BLANK

65C Air Compressor Kit

AMERICAN WIRE GAUGE GUIDE 12-VOLT:

Amp Draw	Length of wire from battery to compressor (in feet)			
	5	10	15	20
5	16	16	16	14
10	16	14	12	10
15	16	12	10	10
20	14	10	10	8
25	14	10	8	6
30	12	10	8	6
40	12	8	6	6
50	10	6	6	4
60	10	6	4	4

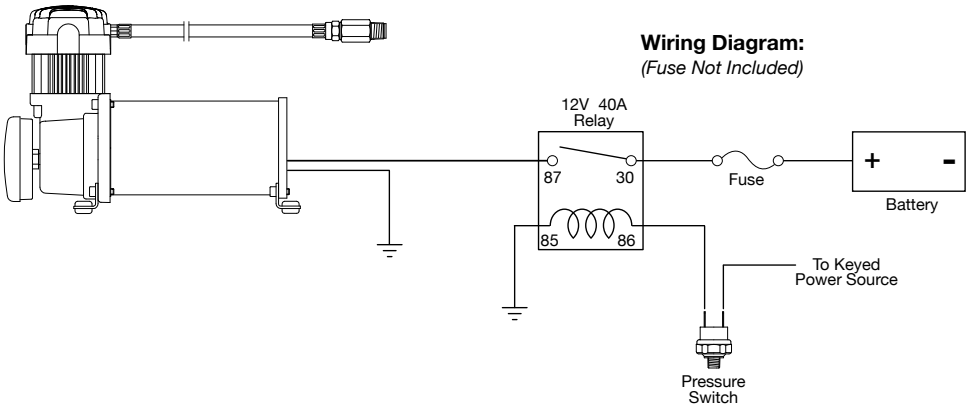

LIMITED WARRANTY:

VIAIR® Corporation warrants this product, when properly installed and under normal conditions of use, to be free from defects in workmanship and materials for a period of one year from its original date of purchase. To receive warranty service or repair, please contact VIAIR® Corporation.

For complete warranty details, please visit: www.viaircorp.com/warranty

PLEASE NOTE:

THIS WARRANTY COVERS PRODUCT DEFECTS ONLY; IT DOES NOT COVER INCIDENTAL OR CONSEQUENTIAL DAMAGES AS RESULT OF MISUSE OR ABUSE.

This Manual is proprietary to VIAIR® Corporation and no ownership rights are hereby transferred. No part of the Manual shall be used, reproduced, translated, converted, adapted, stored in a retrieval system, communicated or transmitted by any means, for any commercial purpose, including without limitation, sale, resale, license, rental or lease, without the prior express written consent of VIAIR®. VIAIR® does not make any representations, warranties or guarantees, express or implied, as to the accuracy or completeness of the Manual. Users must be aware that updates and amendments will be made from time to time to the Manual. It is the user's responsibility to determine whether there have been any such updates or amendments. Neither VIAIR® nor any of its directors, officers, employees or agents shall be liable in contract, tort or in any other manner whatsoever to any person for any loss, damage, injury, liability, cost or expense of any nature, including without limitation incidental, special, direct or consequential damages arising out of or in connection with the use of the Manual.

All third party product names, logos, and brands are property of their respective owners. All company, product service and trademark names are for identification purposes only. Use of these names, logos, and brands does not imply ownership or endorsement.



15 EDELMAN • IRVINE, CA 92618
TEL: (949) 585-0011 • FAX: (949) 585-0188
www.viaircorp.com