

# advanced FLOW engineering

## Instruction Manual P/N: 52-12352-C

---

Make: **Porsche** Model: **911 Carrera/Carrera S (991)** Year: **2012-2015** Engine: **H6-3.4L/3.8L**



- Please read the entire instruction manual before proceeding.
- Ensure all components listed are present.
- If you are missing any of the components, call customer support at 951-493-7100.
- Ensure you have all necessary tools before proceeding.
- Do not attempt to work on your vehicle when the engine is hot.

## Retain factory parts for future use.

Label	Qty.	Description	Part Number
A1	2	Air Filter (Pro 5R)	24-91045
A2	2	Air Filter (Pro DRY S)	21-91045
B	1	Carbon Fiber Tube	05-12352C1
C	1	Housing	05-12352B2
D	1	Carbon Fiber Cover	05-12352C3
E	1	Coupling, Silicone w/ Hole	05-01381
F	1	Sleeve, Silicone	05-01382
G	2	Clamp, #060	03-50002
H	1	Clamp, Mini #024	03-50093
I	1	Cap, Vinyl	03-50408
J	7	Screws, aFe POWER	03-50483
K	2	Ties, Nylon	03-50492
L	2	Cap, Vinyl Mini	03-50484

Installation will require the following tools:

8mm nut driver, 10mm socket & nut driver, T20 & T30 Torx, flathead screwdriver.

Warranty Information available at <https://afepower.com/contact#warranty>

Note: Legal in California for use on race vehicles only. The use of this device on vehicles used on public streets or highways is strictly prohibited in California and others states that have adopted California emission regulations.

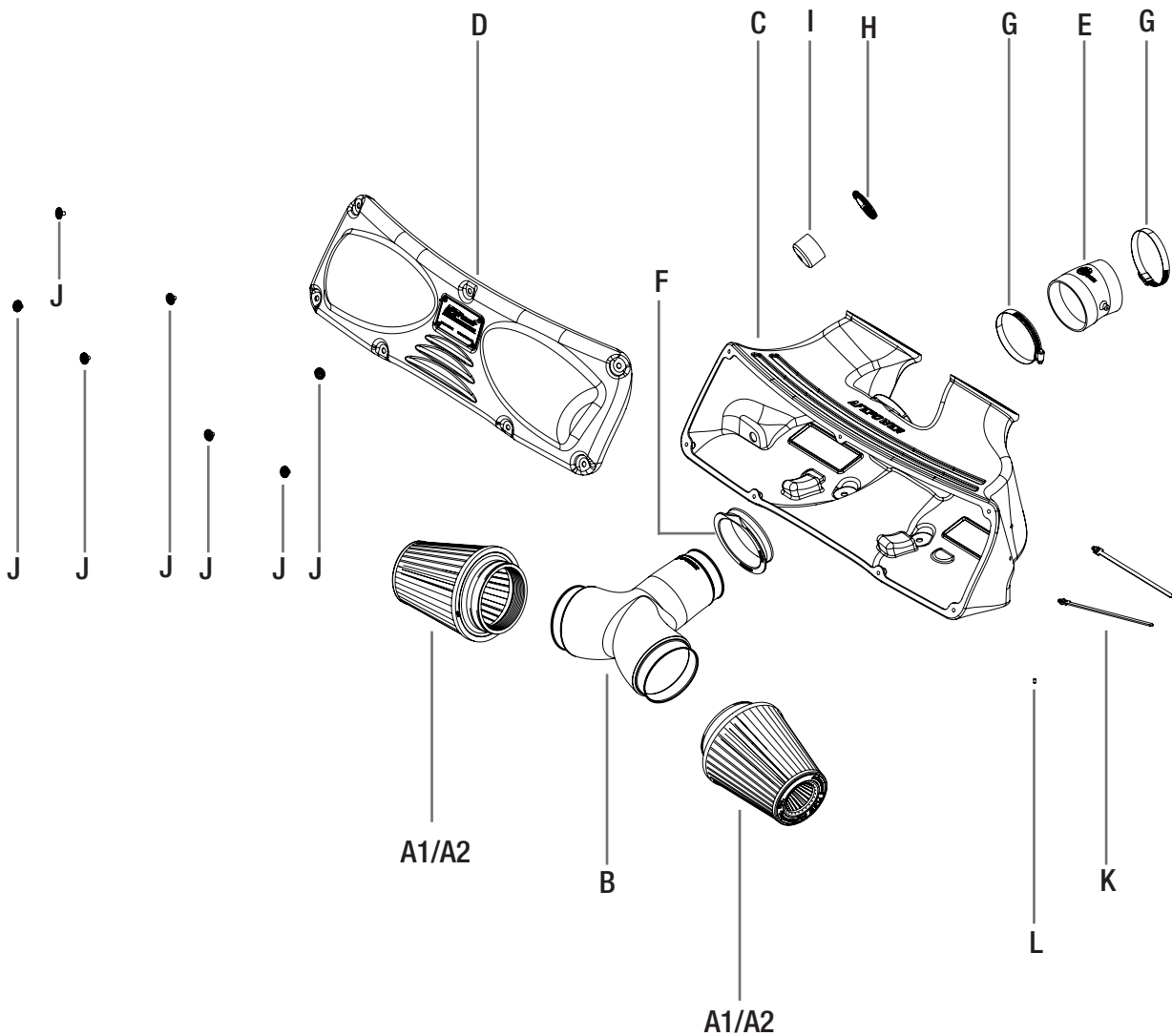

**Figure A****Refer to Figure A for Step 1**

Step 1: Inside the cabin raise the rear wing to its high setting and open the engine compartment.



Figure B

**Refer to Figure B for Step 2**

Step 2: With a pulling motions remove the engine fans off the OE grommets and unplug the fan harness from both sides. Then take the engine cover/fan assembly out of the vehicle.



**Figure C**

**Refer to Figure C for Step 3**

Step 3: Remove the OE scoop by unclipping the latch cable off and pulling the scoop off the OE grommets.





Figure D

**Refer to Figure D for Step 4**

Step 4: Using a T30 Torx remove the screws on the bottom of the bumper.

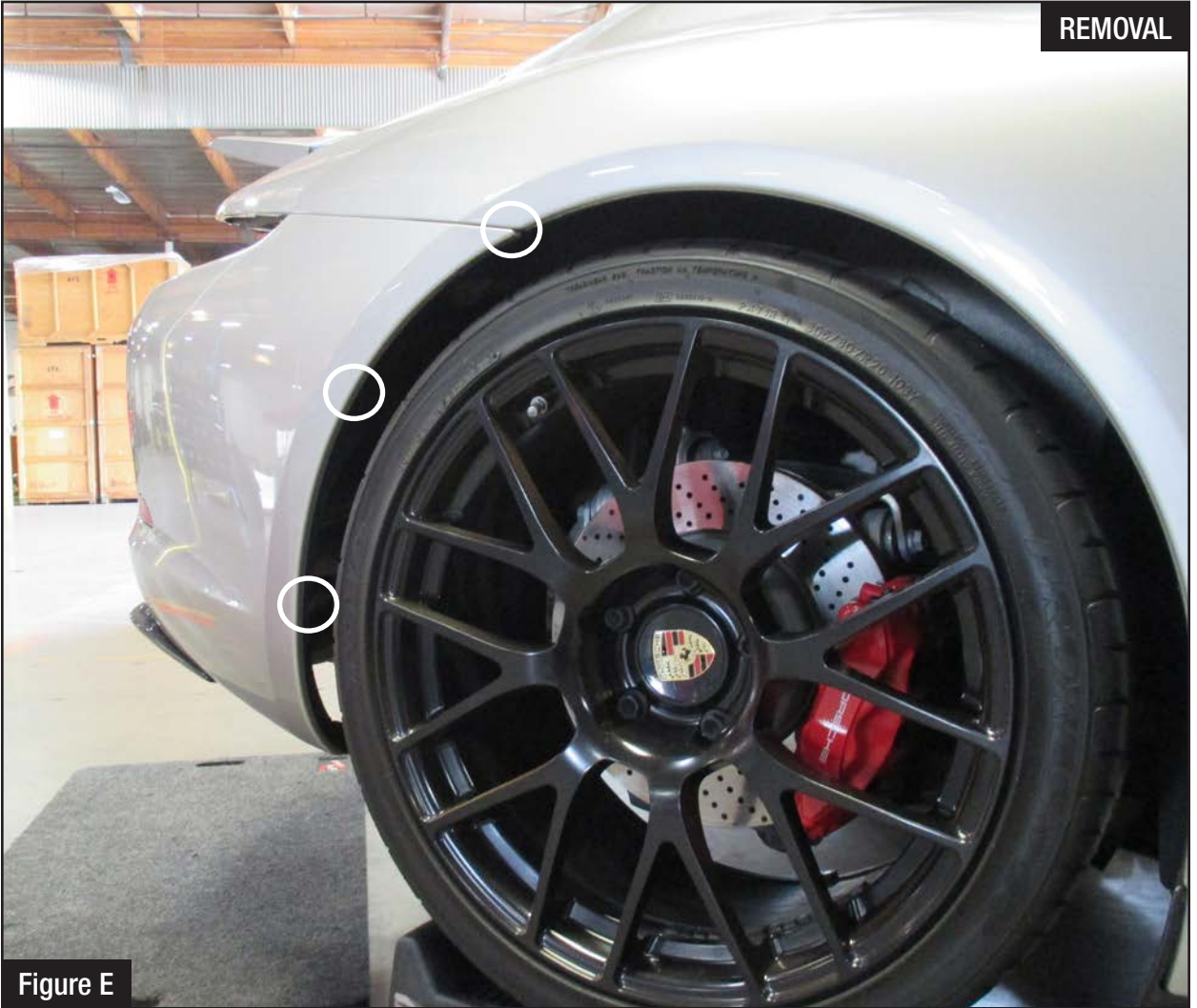

Figure E

**Refer to Figure E for Step 5**

Step 5: Using the T30 Torx remove the three screw on the side of the fender well and bumper. (Repeat for other side)





Figure F

**Refer to Figure F for Steps 6-8**

Step 6: Remove the cover on top for the tail light, to access the tail light bolts. (Repeat for other side)

Step 7: Using a T25 Torx remove two bolts retaining the tail light, Repeat for other side.

Step 8: Pull the tail light out of the vehicle and disconnect it from the harness and remove it, repeat for other side.



Figure G

**Refer to Figure G for Steps 9-10**

Step 9: Using the T30 Torx, remove the four screws on top of the bumper.

Step 10: Slide your hand behind the bumper and disconnect the accessory light harness and unclip it from the inside of the bumper located on the driver side.

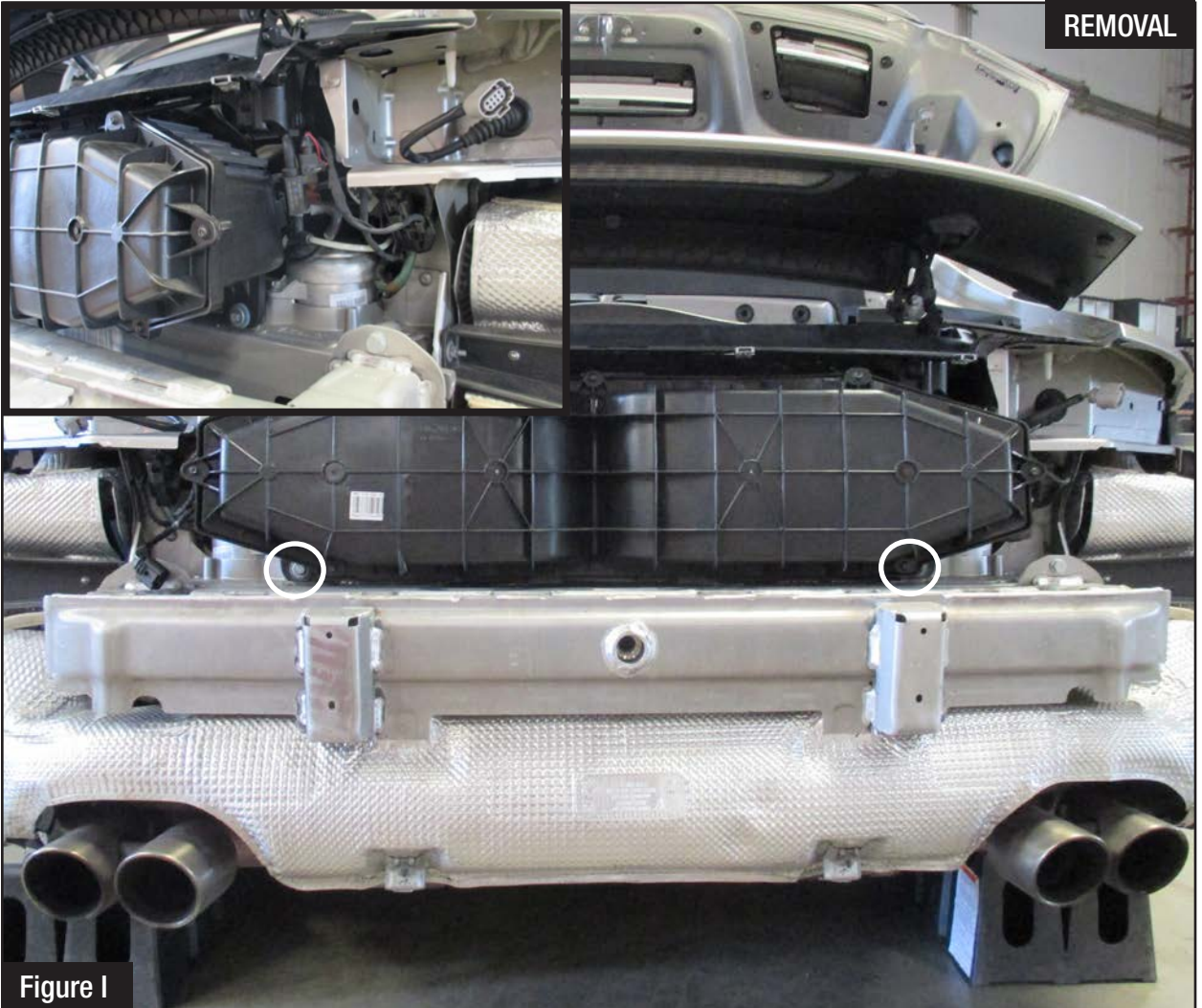

Figure H

**Refer to Figure H for Steps 11-12**

Step 11: Remove the bolt securing the bumper where the tail light was located at. (On bottom side)

Step 12: Carefully remove the bumper.



**Refer to Figure I for Steps 13-15**

Step 13: With a 10mm remove the two bolts retaining the OE Housing.

Step 14: Unclip the changeover valves and detach the sound chamber tube from the OE housing. Untighten the clamp at the throttle body.

Step 15: Carefully remove the OE intake housing out of the vehicle.





Figure J

**Refer to Figure J for Step 16**

Step 16: With the provided rubber caps, cap off both changeover valves.



**Figure K**

**Refer to Figure K for Step 17**

Step 17: Remove the two 9/16" nuts on the heat shield. (Keep the heat shield in its location and save the nuts) Close off the sound chamber with the provided cap and clamp.



Figure L

**Refer to Figure L for Steps 18-19**

Step 18: Pre-install the silicone coupling onto the throttle body with clamps. Do not tighten clamps at this time.

Step 19: Connect the vacuum line to the silicone coupling.



**Figure M**

**Refer to Figure M for Steps 20-24**

- Step 20: Transfer two of the vent grille from the OE housing to the aFe housing.
- Step 21: Transfer the two rubber grommets and steel sleeve into the aFe housing.
- Step 22: Install the aFe housing into the vehicle.
- Step 23: Re-install the two 10mm bolts on the side of the housing.
- Step 24: Re-install the 9/16" nuts on the OE studs.





Figure N

**Refer to Figure N for Step 25**

Step 25: Install the silicone sleeve into the housing, assure the flat side of the silicone sleeve is flat with the top of the housing for proper alignment.



Figure 0

**Refer to Figure 0 for Step 26**

Step 26: Slide the carbon fiber intake tube through the silicone sleeve and into the coupling on the throttle body, do not tighten clamps at this time.

(You may need to use water or lubricant on the sleeve to allow the tube to slide in)





Figure P

**Refer to Figure P for Step 27**

Step 27: Secure the changeover valves with the provided cable ties onto the housing. There is two pre drilled holes for locating the cable ties.



Figure Q

**Refer to Figure Q for Steps 28-30**

Step 28: Install the aFe filters onto the carbon fiber tube.

Step 29: Adjust the tube, filters and coupling assuring the filters sit on the filter stands off.

Step 30: Tighten all clamps at this time.

**Figure R****Refer to Figure R for Steps 31-32**

Step 31: Install the carbon fiber cover onto the housing.

Step 32: Loosely install the seven aFe engraved washer and screw until all are threaded then tighten all.



**Figure S**

**Refer to Figure S for Steps 33-34**

Step 33: Re-install the rear bumper, tail lights, OE scoop and engine fans. Refer to Steps 1-13.

Step 34: Your installation is now complete.

**NOTE: Check all bolts, clamps, and connectors after 200 miles.**

Page left blank intentionally





**advanced FLOW engineering, inc.**  
252 Granite Street Corona, CA 92879  
<https://afepower.com/contact>