

advanced FLOW engineering Magnum FORCE Stage-2 Cold Air Intake System

Instruction Manual P/N: 54-13015D / 54-13015R

Make: Ford

Model: Mustang GT

Year: 2015-2017

Engine: V8 – 5.0L (Coyote)



- Please read the entire instruction manual before proceeding.
- Ensure all components listed are present.
- If you are missing any of the components, call customer support at 951-493-7100.
- Ensure you have all necessary tools before proceeding.
- Do not attempt to work on your vehicle when the engine is hot.
- Disconnect the negative battery terminal before proceeding.
- Retain factory parts for future use.

Label	Qty.	Description	Part Number
A1	1	Air Filter (Pro 5R)	24-91037
A2	1	Air Filter (Pro DRY S)	21-60507
B	1	Tube	05-5413015B1
C	1	Housing	05-5413015B2
D	1	Coupling, Silicone Reducer:(3.90"x3.50")ID x 2.35"L	05-01358
E	2	Fitting, Vent Tube: Ford F-150 (Small)	05-01338
F	1	Fitting, Vent Tube: Ford F-150 (Large)	05-01339
G	1	Cap, Vinyl 1"-1-1/16" OD	03-50623
H	1	Clamp, 056 (3-1/16" – 4")	03-50009
I	1	Clamp, 060 (3-5/16" – 4-1/4")	03-50002
J	2	Screw, Torx: M4	03-50490
K	1	Seal, Trim (42" Length)	05-00072
L	1	Gasket, MAF	05-00631
M	2	Washer, Lock: M6	03-50071
N	2	Washer, Flat: M6	03-50070
O	2	Screw, Hex Hd: M6x16	03-50052
P	1	Plug, Hex Hd, Socket: 1/8" NPT	03-50029

Installation will require the following tools:

T-20 Torx Driver, 8mm nut driver, 10mm Nut Driver, Pliers, Flat Head Screw Driver and an adjustable wrench.

Emissions Disclaimer: This product is not currently CARB exempt and is not available for purchase in California or for use on any vehicle registered with the California Department of Motor Vehicles.

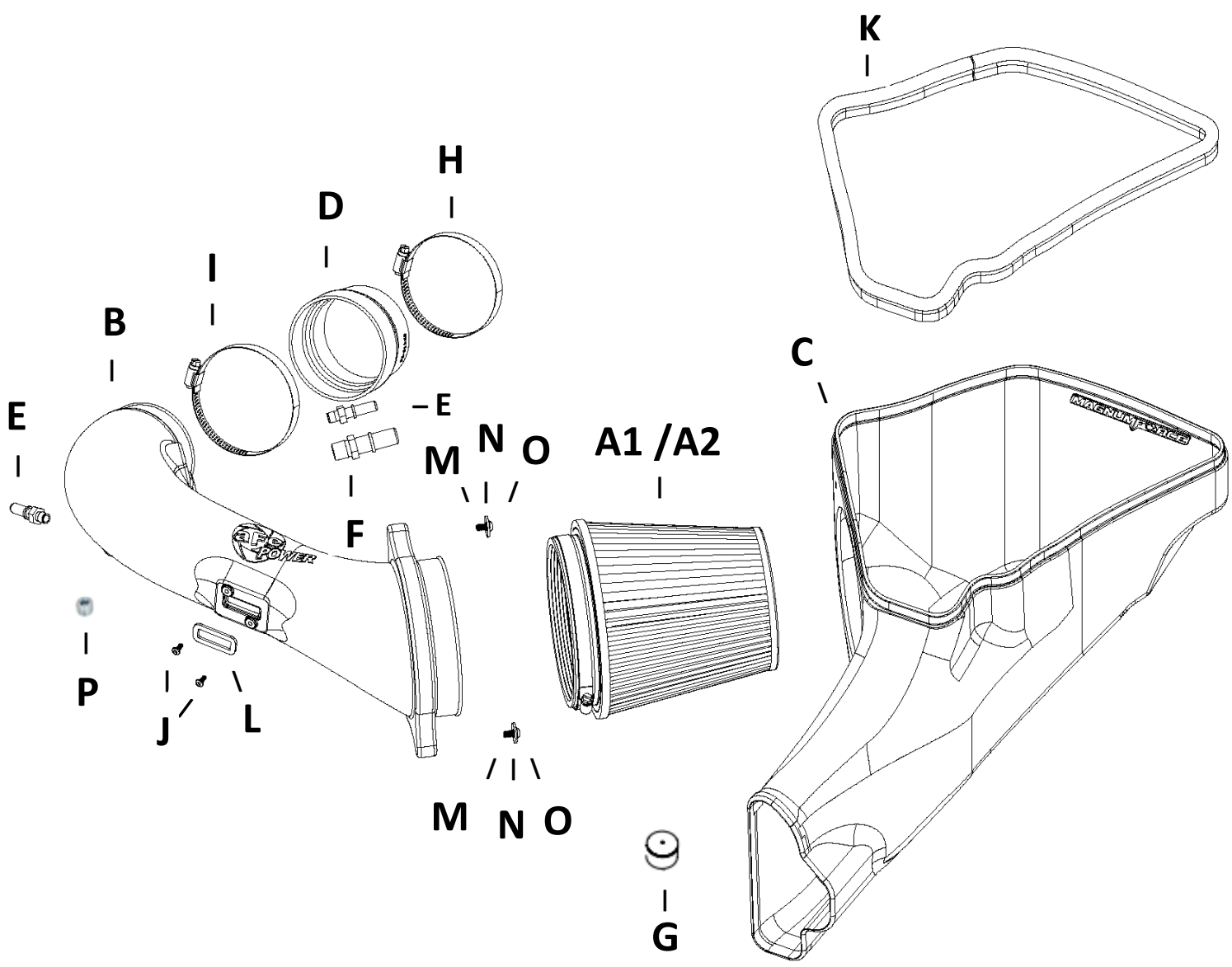



Figure A

Refer to Figure A for Steps 1-3

Step 1: Remove the engine cover by lifting upward on the 4 mounting locations.

Step 2: Locate the two factory clamps (1) on the stock intake tube. Using an 8mm nut driver, loosen the clamps at the housing (2) and throttle body (3).

Step 3: Find the three vacuum fittings (4) on the front and back of the intake tube and disconnect them.



Figure B

Refer to Figure B for Steps 4-6

Step 4: Locate the sound tube (5) attached to the intake by a black clamp.

Step 5: Using a pair of pliers, remove the black spring clamp (6).

Step 6: Using a flat-head screw-driver, remove the other half of the sound tube (7) attached to the chamber near the shock tower.

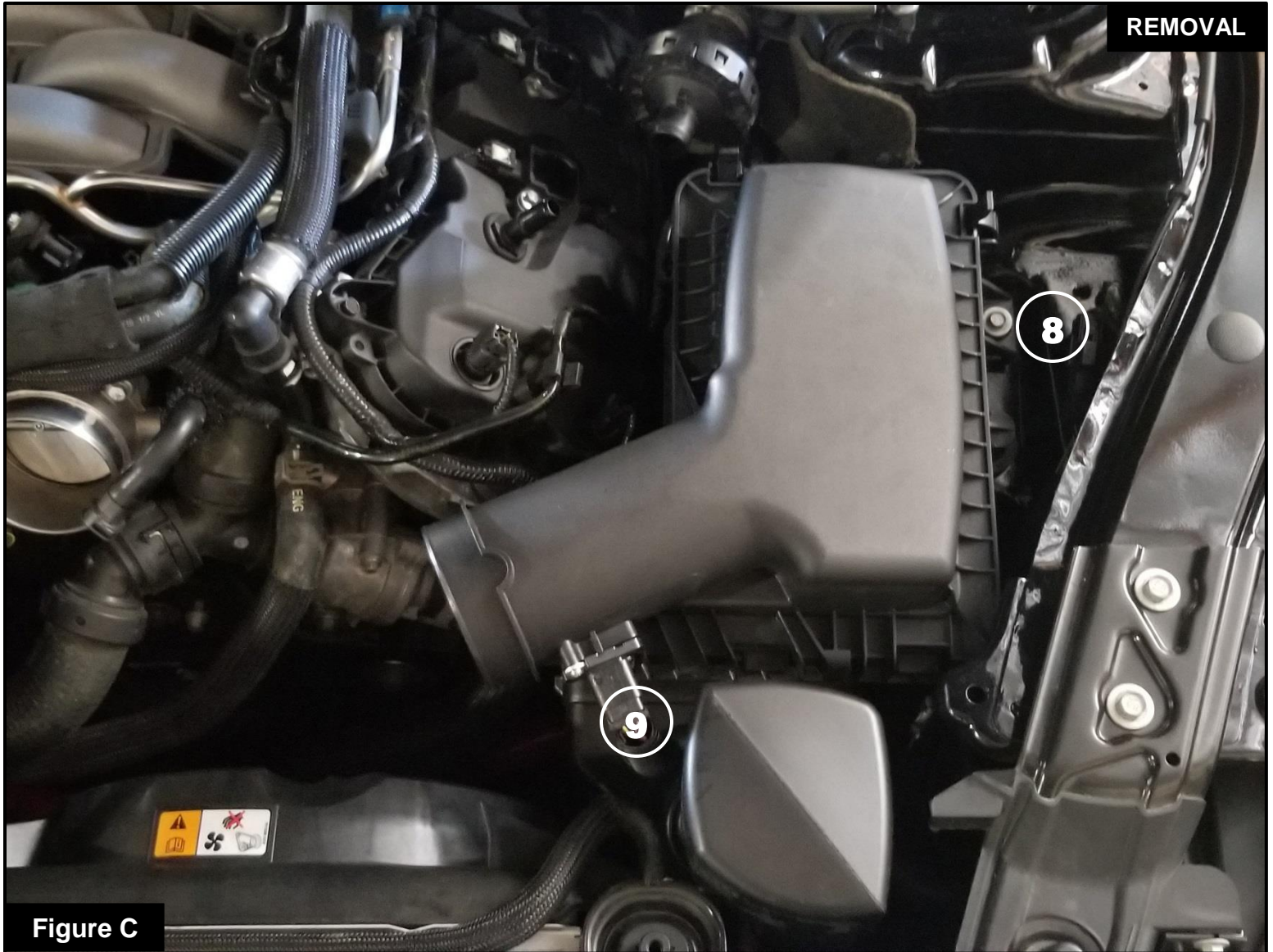

Figure C

Refer to Figure C for Step 7-8

Step 7: Using a 10mm nut driver, remove the bolt (8) securing the housing and set aside for later use.

Step 8: Disconnect the MAF sensor clip (9), then pull up on the housing to remove it from the vehicle.

**Figure D****Refer to Figure D for Step 9**

Step 9: Install the 3 supplied vent fittings (10) into their respective locations on the aFe Power intake tube and tighten them using an adjustable wrench. Install the supplied 1/8" NPT plug if your vehicle does not use all three fittings.



Refer to Figure E for Steps 10 - 11

Step 10: Using a 10mm nut driver, attach the tube to the housing using the supplied hardware (11) with the flat washer, lock washer, and screw in that order.

Step 11: Install the provided trim-seal (12) onto the top of the housing.



Refer to Figure F for Step 12

Step 12: Remove the grommets (13) from the stock housing and transfer them into the respective locations on the aFe Power airbox.

**Figure G****Refer to Figure G for Steps 13-14**

Step 13: Using a T20 torx driver, remove the 2 screws (14) holding the MAF into the stock housing.

Step 14: Install the supplied gasket (15) onto the MAF and install into the aFe Power intake tube using the 2 supplied M4 screws (16).

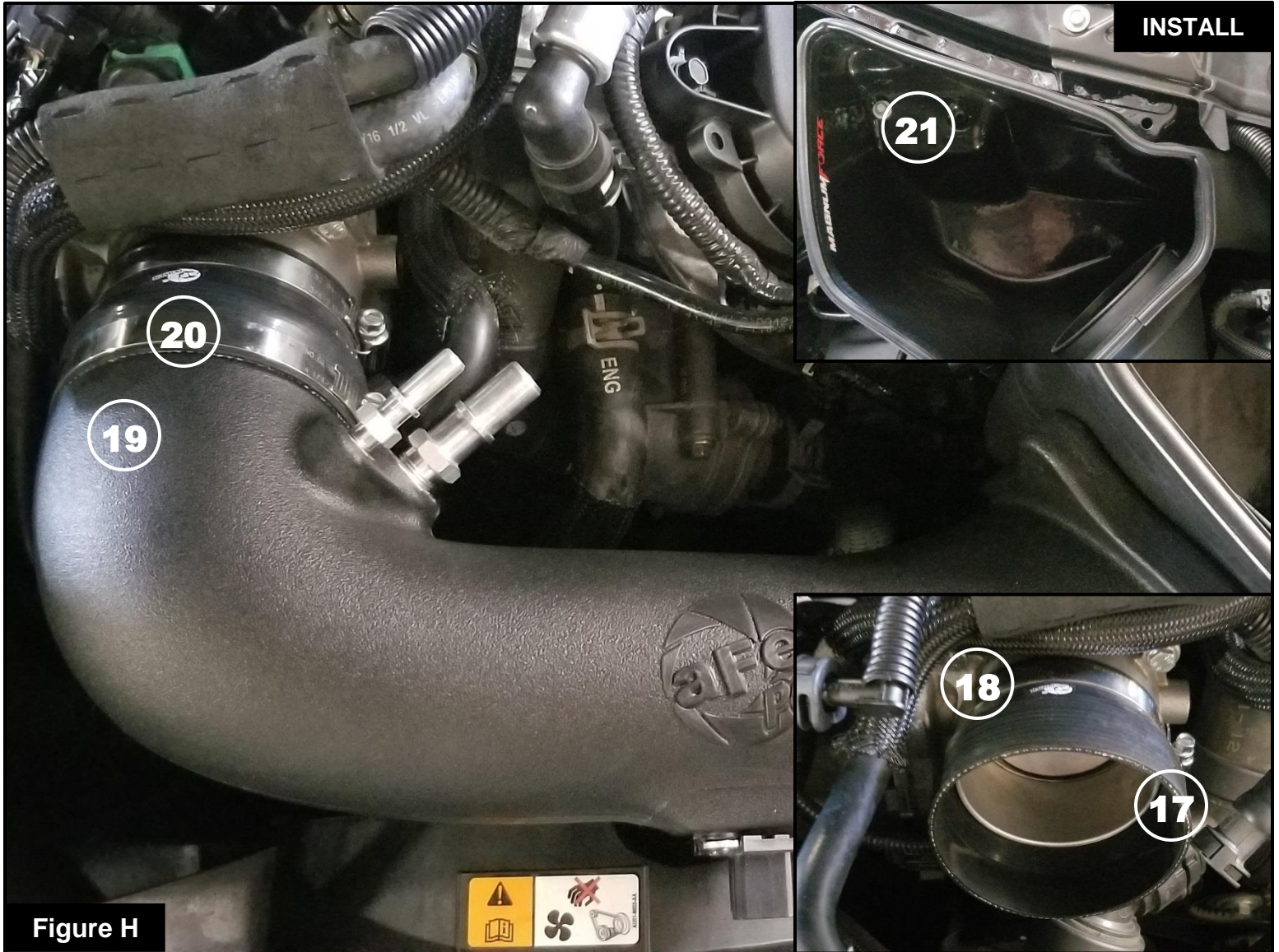

Figure H

Refer to Figure H for Steps 15-17

Step 15: Slip the supplied coupling (17) and clamp (18) over the throttle body and tighten clamp using an 8mm nut driver.

Step 16: Install the aFe Power airbox and tube assembly into the vehicle and slip the end of the tube (19) into the coupling. Install the larger hose clamp (20) and tighten using and 8mm nut driver.

Step 17: Use the 10mm bolt (21) you set aside earlier and install it into the grommet on the inside edge of the aFe Power airbox and tighten using a 10mm nut driver.

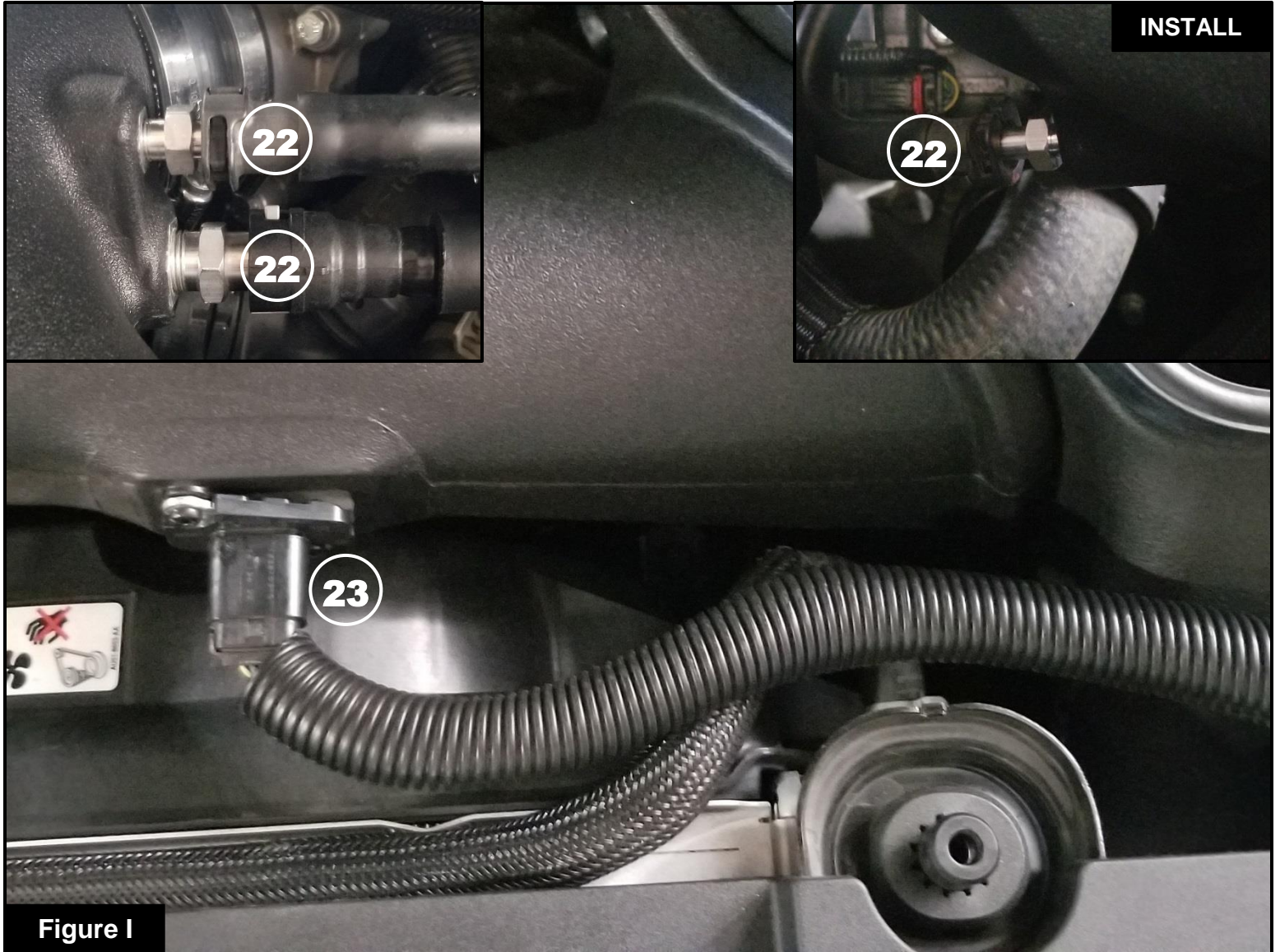

Figure I

Refer to Figure I for Steps 18-19

Step 18: Install the 3 fittings (22) that were disconnected earlier and ensure that they are securely fastened.

Step 19: Re-connect the MAF sensor (23) with the red tab facing down.



Refer to Figure J for Steps 20-21

Step 20: Install the filter and clamp (24) onto the larger end of the tube and tighten clamp using an 8mm nut driver.

Step 21: Slip the supplied vinyl cap (25) over the sound chamber snout.



Figure K

Refer to Figure K for Step 22

Step 22: Check that all components are tight and secure. Your installation is now complete. Thank you for choosing aFe POWER!

NOTE: Check all bolts, clamps, and connectors after 100-200 miles.



Page left blank intentionally



Page left blank intentionally



Page left blank intentionally



Pro DRY S Air Filter



P/N: 21-60507

Pro 5R Air Filter



P/N: 24-91037

Pro DRY S Restore Kit



P/N: 90-59999

Blue Squeeze Restore Kit



P/N: 90-50501

Throttle Body Spacer



P/N: 46-33020

SPRINT BOOSTER V3



P/N: 77-13005

Cat-Back Exhaust System



P/N: 49-33088-B (Blk. Tips)
49-33088-P (Pol. Tips)
For V6-3.7L/V8-5.0L Models!

Axle-Back Exhaust System



P/N: 49-43105-C (CF. Tip)
49-43105-B (Blk. Tips)
49-43105-P (Pol. Tips)
For V8 – 5.0L Models!

To purchase any of the items above, view airflow charts, dyno graphs, photos, and video; please go to aFepower.com.

Warranty



General Terms:

- aFe warrants their products to be free from manufacturer’s defects due to workmanship and material.
- This warranty applies only to the original purchaser of the product and is non-transferrable.
- Proof of purchase of the aFe product is required for all warranty claims.
- Warranty is valid provided aFe instructions for installation and/or cleaning were properly followed.
- Proper maintenance with regular inspections of product is required to insure warranty coverage.
- Damage due to improper installation, abuse, unauthorized repair or alteration is not warranted.
- Incidental or consequential damages or cost, including installation and removal of part, incurred due to failure of aFe product is not covered under this warranty.
- All warranty is limited to the repair and/or replacement of the aFe part. To request Return Goods Authorization (“RGA”), email RGA@afepower.com or call (951)493-7100. Upon receipt of the RGA, you must return the product to the address provided in the RGA, freight prepaid and accompanied with a dated proof of purchase and the RGA. Upon receipt of the defective product and upon verification of proof of purchase, aFe will either repair or replace the defective product within a reasonable time, not to exceed thirty days.

Product Category	P/N Prefix	Warranty duration
Direct OE Replacement Filters	10, 11, 30, 31, 71, 73	Life of the vehicle
Racing Filters	18	1 year
Universal	20, 21, 23, 24, 72, TF	2 years
Air Intake Systems	50, 51, 53, 54, 55, 56, 57, 58, 75, TR, TA, TL, TM	2 years
Exhaust Systems	49	2 years
Intercoolers & Intercooler Tubes	46-2	2 years
Intake Manifolds	46-1	2 years
Differential Cover	46-7	Life of the vehicle
Exhaust Manifolds	46	2 years
Throttle Body Spacers	46-3	2 years
Turbochargers	46-6	2 years*
Fluid Filters	44	90 days
Pre-Filters	28	2 years
Heavy Duty OE Replacement	70	2 years
PowerSports OE Replacement	81, 87	2 years
PowerSports Intake Systems	85	2 years

No other warranty expressed or implied applies nor is any person or advanced FLOW engineering authorized to assume any other warranty. Some States do not allow the exclusion or limitation of incidental or consequential damages or do not allow limitations on how long an implied warranty lasts, so the above limitations or exclusions may not apply to you. This warranty gives you specific legal rights, and you may also have other rights which vary from State to State.

*See turbocharger warranty for more info



advanced FLOW engineering, inc.

252 Granite Street Corona, CA 92879
TEL: 951.493.7100 • TECH: 951.493.7134
E-Mail: Tech@aFepower.com

P/N: 06-81234