

advanced FLOW engineering Magnum Force Stage-2 Cold Air Intake System

Instruction Manual P/N: 54-13065D / 54-13065R

Make: Chevrolet	Model: Silverado 2500 HD	Year: 2007.5-2010	Engine: V8-6.6L(td)
Make: Chevrolet	Model: Silverado 3500 HD	Year: 2007.5-2010	Engine: V8-6.6L(td)
Make: GMC	Model: Sierra 2500 HD	Year: 2007.5-2010	Engine: V8-6.6L(td)
Make: GMC	Model: Sierra 3500 HD	Year: 2007.5-2010	Engine: V8-6.6L(td)



- Please read the entire instruction manual before proceeding.
- Ensure all components listed are present.
- If you are missing any of the components, call customer support at 951-493-7185.
- Ensure you have all necessary tools before proceeding.
- Do not attempt to work on your vehicle when the engine is hot.
- Retain factory parts for future use.

Label	Qty.	Description	Part Number
A	1	Air Filter (Pro 5R) for 54-13065R	24-91154
A	1	Air Filter (Pro DRY S) for 54-13065D	21-91154
B	1	Tube	05-82312B1
C	1	Housing	05-5413016B2
D	1	Seal, Trim: 13/32" Double Bulb (37.5" Length)	05-01534
E	2	Clamp, 072 (3"-5")	03-50010
F	2	Torx Screw: M4	03-50491
G	1	Plug with Tab	03-50766
H	1	Coupling, Silicone Bellow	05-01430
J	1	Seal, Trim: 3/4" Bulb (26" Length)	05-01507

Installation will require the following tools:

8mm nut driver, T20 Torx driver, small flat-head screwdriver, Phillips screwdriver.

Warranty Information available at: <https://afepower.com/contact#warranty>

Emissions Disclaimer: This product is not currently CARB exempt and is not available for purchase in California or for use on any vehicle registered with the California Department of Motor Vehicles.

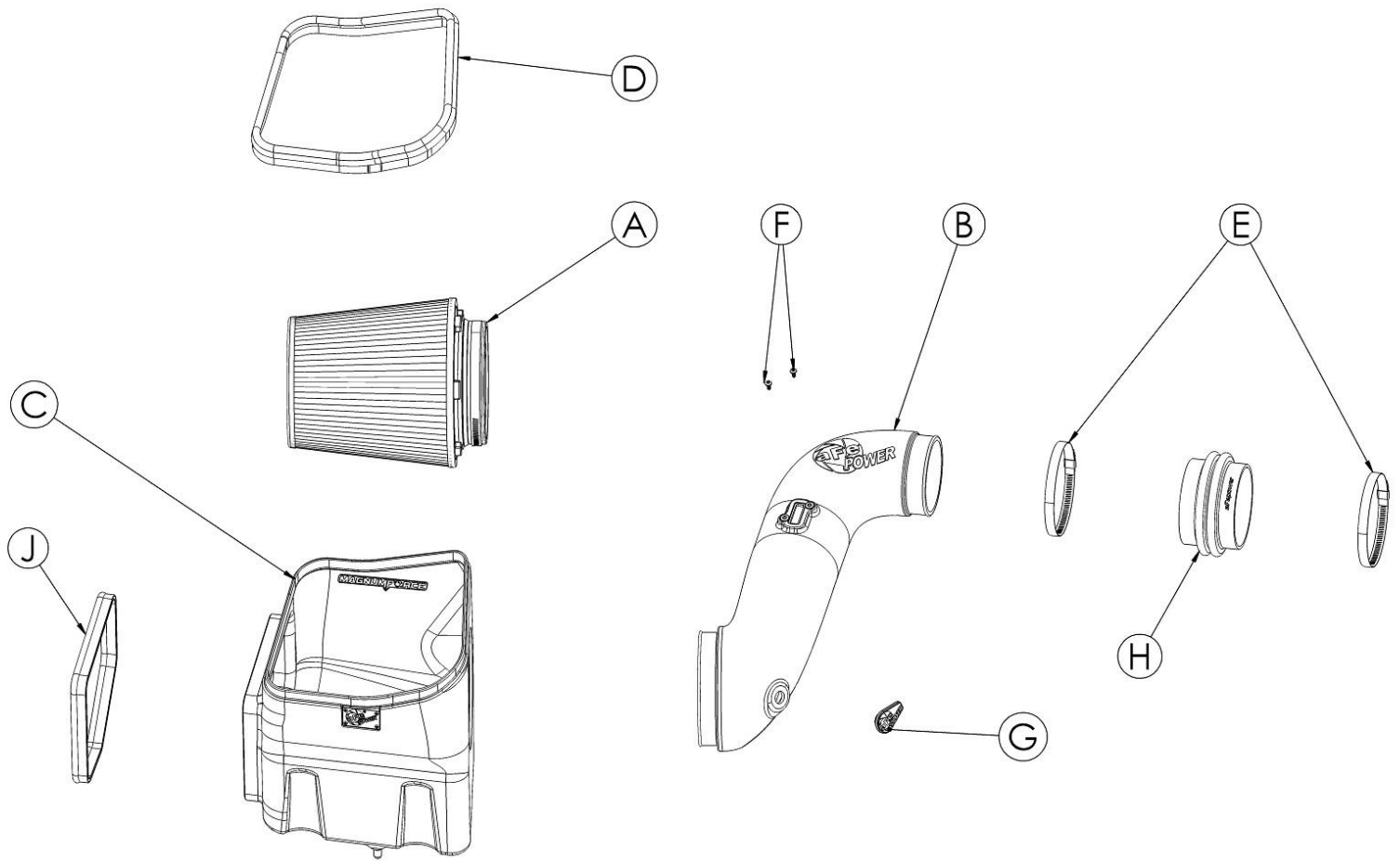

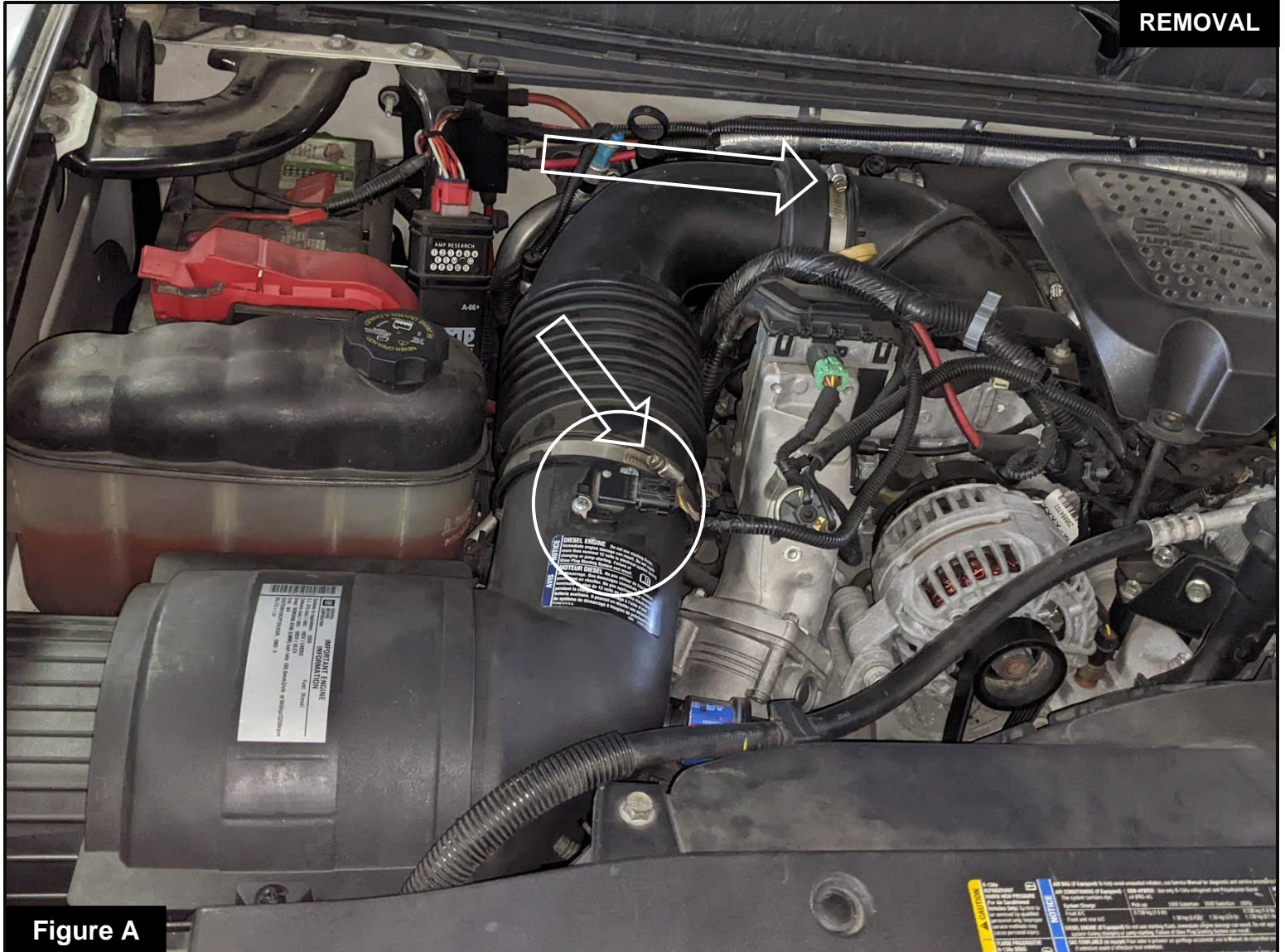
**Figure A**

Refer to Figure A for Steps 1-3

Step 1: Disconnect the circled plug for the MAF sensor.

Step 2: Loosen all tube clamps using an 8mm nut driver (arrows).

Step 3: Remove the factory intake tube and air box out of the vehicle. (Use an upward pull to release the air box from its mounting grommets).

**Figure B**

Refer to Figure B for Steps 4-5

Step 4: Install the supplied air filter into the aFe POWER housing. Place the air filter into the large opening at the top, then slip the air filter mouth into the round opening on the aFe POWER housing, making sure the air filter's lip locks into place.

Step 5: Install the shorter seal trim on side of the aFe POWER housing.



Figure C

Refer to Figure C for Step 6

Step 6: Install the longer seal trim on the top of the aFe POWER housing.



Figure D

Refer to Figure D for Steps 7

Step 7: Remove the retaining plug from the bottom of the factory housing and transfer it to the aFe POWER housing.

**Figure E****Refer to Figure E for Step 8-11**

Step 8: Remove the retaining plug from the bottom of the factory housing and transfer it to the aFe POWER housing.

Step 9: Remove the factory sensors from the factory air box using a Phillips screwdriver. The filter minder will be able to be removed by gently, but firmly, pulling it out.

Step 10: Transfer over the MAF sensor to the aFe POWER tube, using the supplied Torx M4 hardware.

Step 11: Transfer the factory filter minder to the aFe POWER tube, using the supplied Grommet. If the vehicle is not equipped with a filter minder, use the supplied Grommet and Cap in its place.

**Figure F**

Refer to Figure F for Steps 12-13

Step 12: Install the aFe POWER housing assembly into the vehicle. Firmly push the housing into the factory mounting grommets.

Step 13: Put the filter clamp over the filter flange but do not tighten yet.

**Figure G****Refer to Figure G for Step 13**

Step 14: Slip the coupler over the turbo inlet and tighten it down with one of the supplied worm clamps.

**Figure H****Refer to Figure H for Steps 14-16**

Step 15: Slip the other worm clamp over the other end of the bellows coupling. Do not tighten yet.

Step 16: Install the aFe POWER intake tube into the vehicle. Slide the aFe POWER intake tube into the filter and then into the coupling on the turbo inlet.

Step 17: Align the aFe POWER intake tube correctly then tighten all the clamps.



Refer to Figure I for Steps 17-18

Step 18: Reconnect the MAF Sensor harness.

Step 19: Check all the components are tight and secure. Your installation is now complete. Thank you for choosing aFe POWER!

NOTE: Check all screws, clamps, and connectors are secure after 100-200 miles.



Page left blank intentionally



Page left blank intentionally



Page left blank intentionally



advanced FLOW engineering, inc.

Corona, CA 92879

<https://afepower.com/contact>