

advanced FLOW engineering Magnum FORCE Stage-2 Cold Air Intake System

**Instruction Manual** P/N: 54-13079D / 54-13079R

Make: Jeep

Model: Wrangler (JL)

Year: 2018-2023

Engine: I4-2.0L (t)



- Please read the entire instruction manual before proceeding.
- Ensure all components listed are present.
- If you are missing any of the components, call customer support at 951-493-7185.
- Ensure you have all necessary tools before proceeding.
- Do not attempt to work on your vehicle when the engine is hot.
- Retain factory parts for future use.

Label	Qty.	UoM	Description	Part Number
A1	1	Ea	Air Filter (Pro DRY S)	24-91203D
A2	1	Ea	Air Filter (Pro 5R)	24-91203R
B	1	Ea	Tube	05-5413079B1
C	1	Ea	Housing	05-5413078B2
D	1	Ea	Coupling, Silicone Bellows 3-1/4"ID x 3"L	05-01480
E	2	Ea	Clamp, 048	03-50007
F	1	Ea	Fitting, CCV Vacuum	05-01499
G	1	Ea	Retainer Clip, Christmas Tree Style for 1/4" Hole	05-01350
H	1	Ea	Grommet, Rubber Small	03-50268
J	1	Ea	Grommet, Rubber Large	03-50167
K	1	Ea	Fitting, Intake Air Temp Sensor	05-01454
M	34.5	In	Seal, Trim: 3/4" Bulb	05-01507

**Installation will require the following tools:**

8mm nut driver or flat head screwdriver, 10mm socket and wrench, panel clip pliers or similar.

Warranty Information available at: <https://afepower.com/contact#warranty>

**Emissions Disclaimer:** This product is not currently CARB exempt and is not available for purchase in California or for use on any vehicle registered with the California Department of Motor Vehicles.

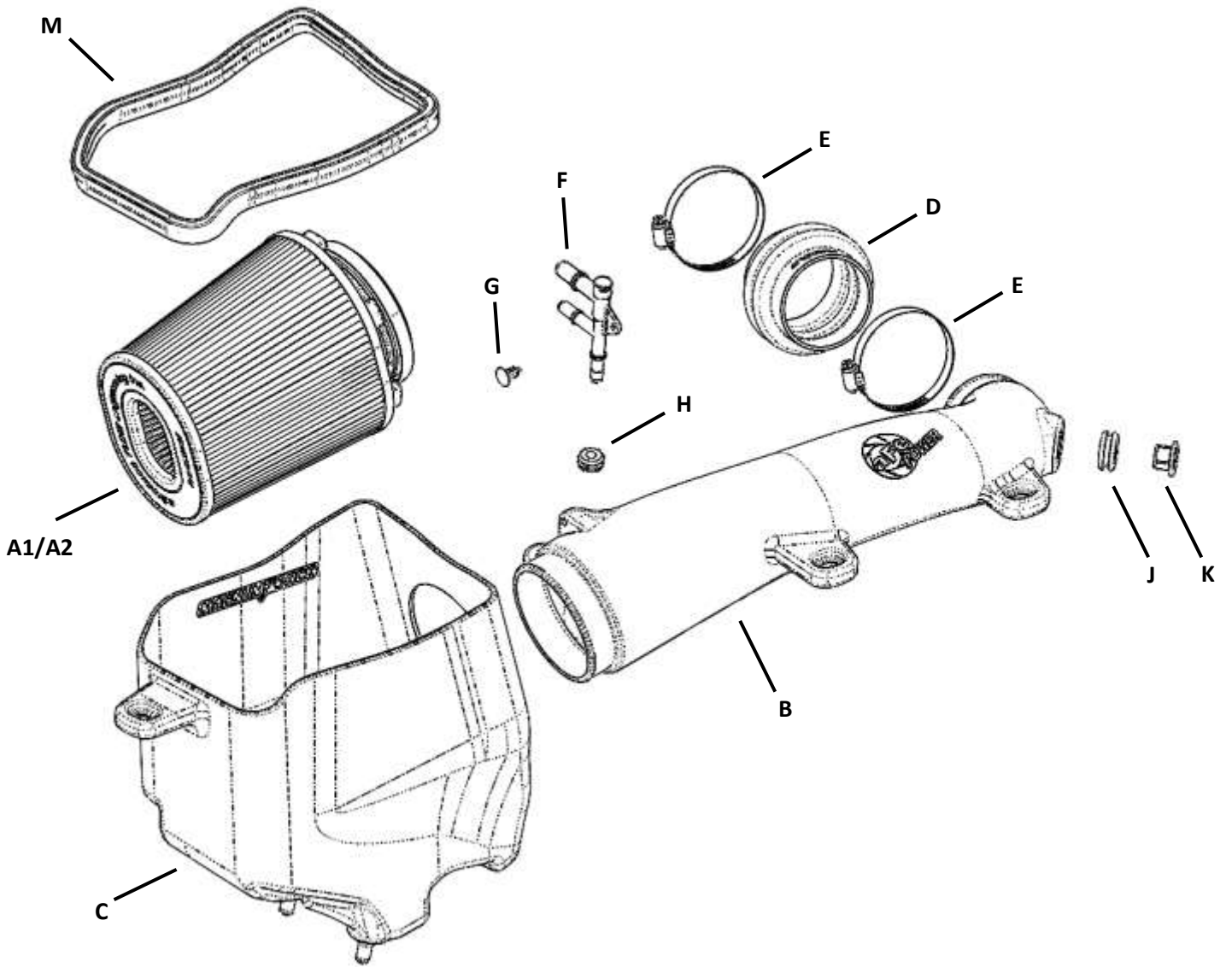

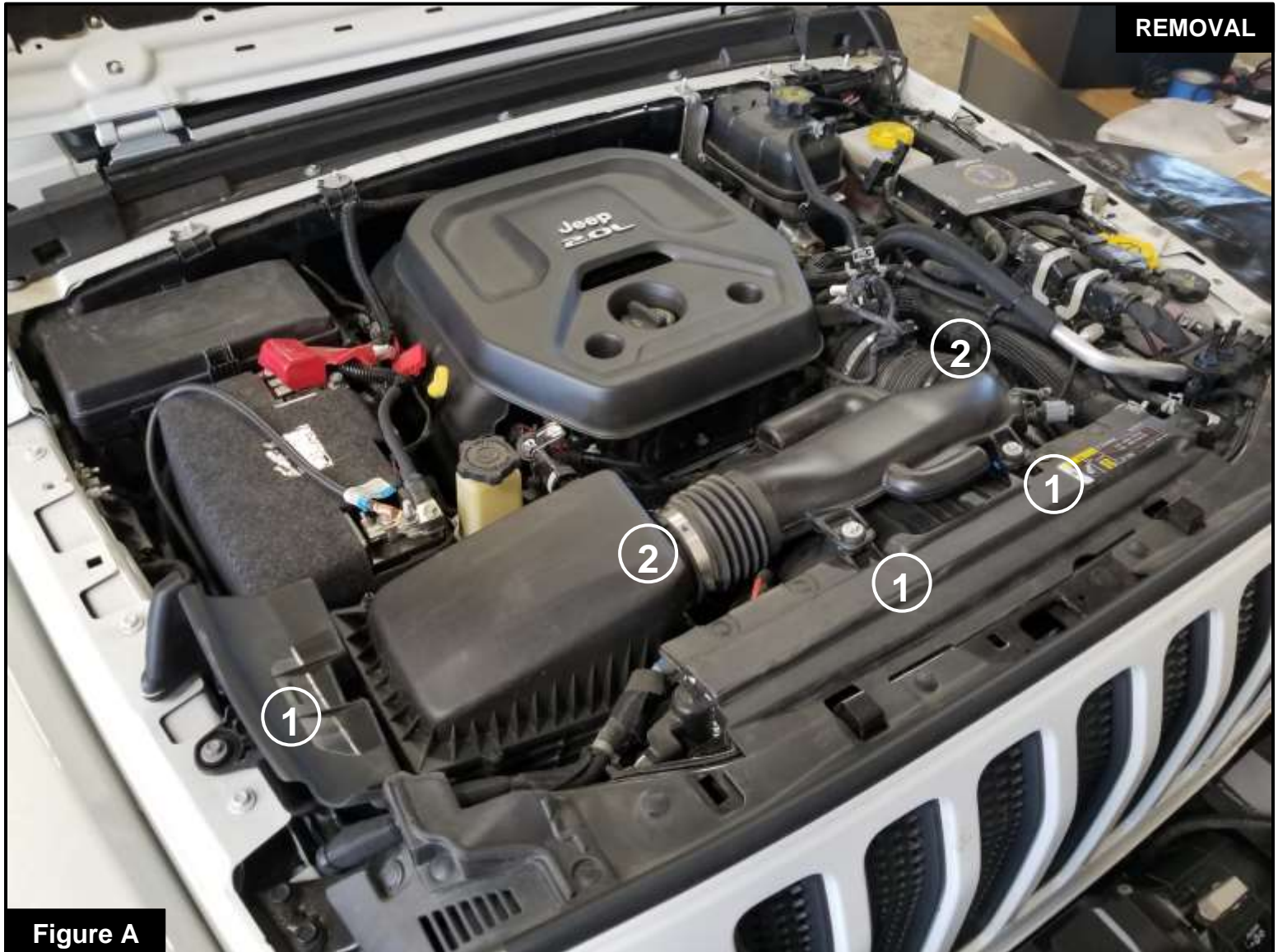

Figure A

### Refer to Figure A for Steps 1-2

**Step 1:** Using a 10mm socket and driver, remove the (3) screws (1) securing the OE intake to the vehicle.

**Step 2:** Using an 8mm nut driver, loosen the two clamps (2) on the intake tube.

**Figure B****Refer to Figure B for Steps 3-5**

**Step 3:** Disconnect the two vent lines that are connected to the vacuum generator (3) by pushing on the grey clips and sliding the tubes off the fittings.

**Step 4:** Disconnect the Intake Air Temperature (IAT) sensor (4).

**Step 5:** Remove the attaching clip for the IAT sensor harness (5) and move the harness out of the way for now.



### **Refer to Figure C for Steps 6-8**

**Step 6:** Remove the OE intake tube from the vehicle.

**Step 7:** Remove the OE housing from the vehicle by lifting straight upward. If the rubber grommets pop off with the housing, then remove them from the housing and place them back into the holes in the mounting bracket.

**Step 8:** If the attaching clip on the IAT sensor harness is bent out of shape, then repair it so that it looks like the clip shown in the small photo.

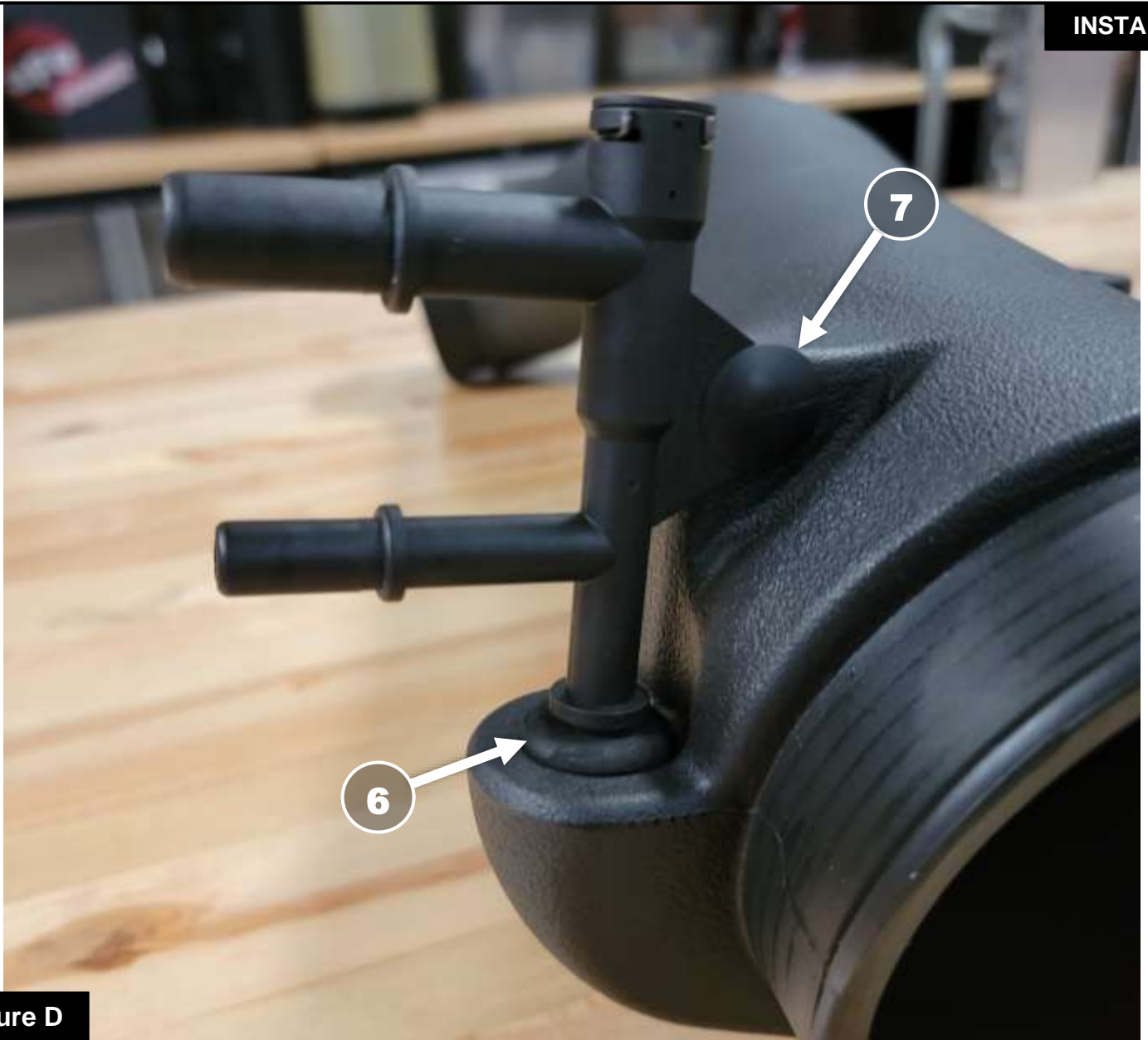
**Figure D****Refer to Figure D for Step 9-11**

**Step 9:** Install the small rubber grommet (6) provided into the small hole on the aFe POWER intake tube.

**Step 10:** Install the CCV Vacuum Fitting into the grommet as shown.

**Step 11:** Install the push clip (7) to retain the CCV Vacuum Fitting to the aFe POWER intake tube.

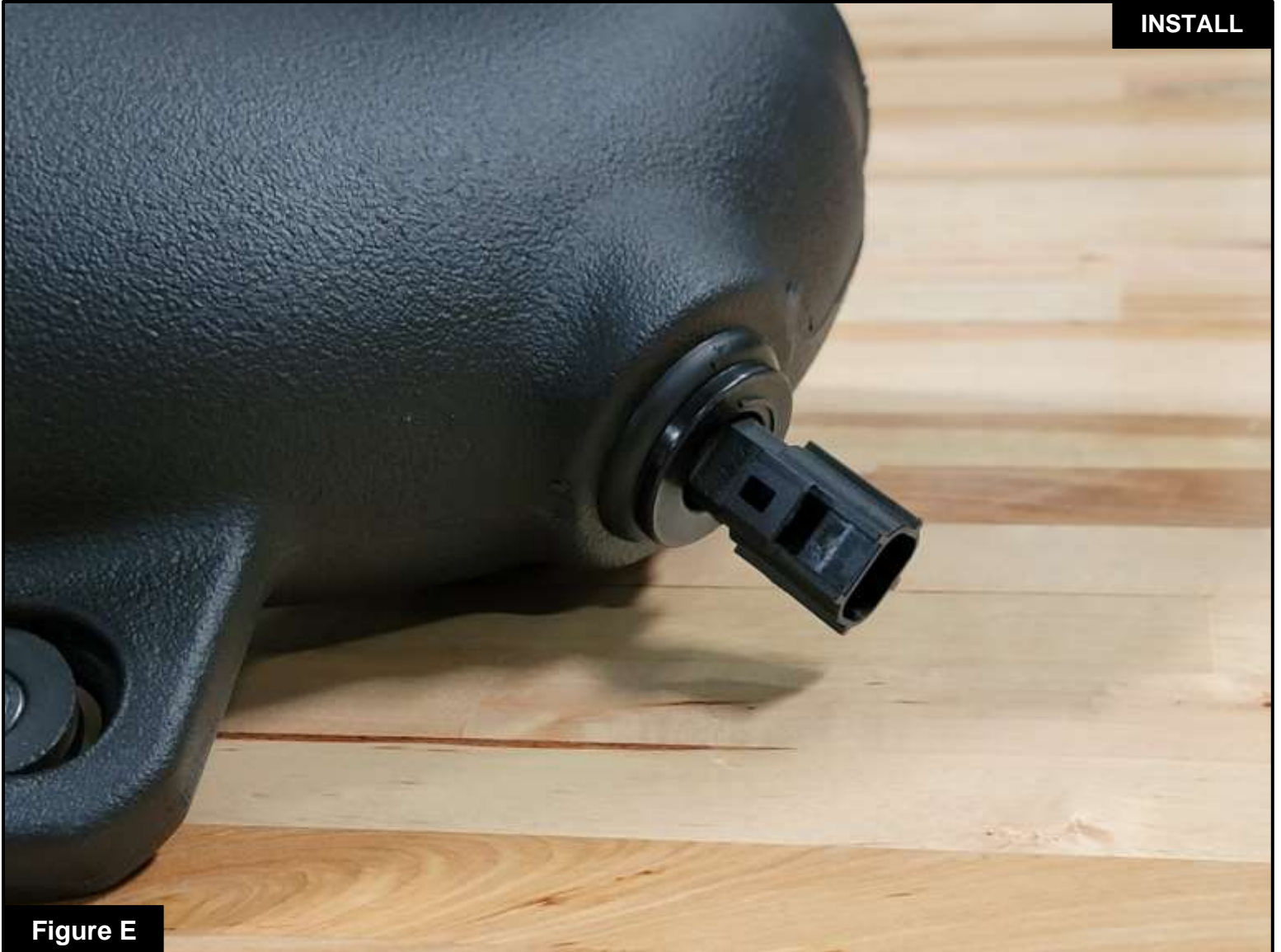
**Figure E**

### **Refer to Figure E for Steps 12-15**

**Step 12:** Remove the IAT Sensor from the factory intake tube by lifting the locking tab, rotating the sensor a quarter-turn counterclockwise, and then pulling the sensor straight out.

**Step 13:** Install the large rubber grommet into the large hole on the aFe POWER intake tube.

**Step 14:** Install the supplied IAT Fitting into the large rubber grommet.

**Step 15:** Install the IAT Sensor into the IAT Fitting, and rotate it clockwise a quarter-turn to lock it into place.

Make sure the locking tab clicks past the retainer on the IAT Fitting.

**Note:** *The orientation of the sensor is not critical.*



**Figure F****Refer to Figure F for Steps 16-18**

- Step 16:** Remove the (2) two rubber mounting grommets and steel sleeves from the factory intake tube.
- Step 17:** Install the (2) two rubber mounting grommets and steel sleeves (8) into the aFe POWER intake tube as shown.
- Step 18:** Install the bellows coupling (9) onto the end of the tube and preinstall the two clamps onto the coupling. Do not tighten the clamps at this time.

**Figure G**

### **Refer to Figure G for Steps 19-22**

**Step 19:** Remove the rubber mounting grommet and steel sleeve from the factory intake housing.

**Step 20:** Install the rubber mounting grommet and steel sleeve (10) into the aFe POWER intake housing as shown.

**Step 21:** Install the trim seal (11) around the top of the housing. Make sure to press down firmly all around the trim seal to ensure a good fit.

**Step 22:** Install the aFe POWER air filter into the housing and loosely install the clamp over the filter flange.

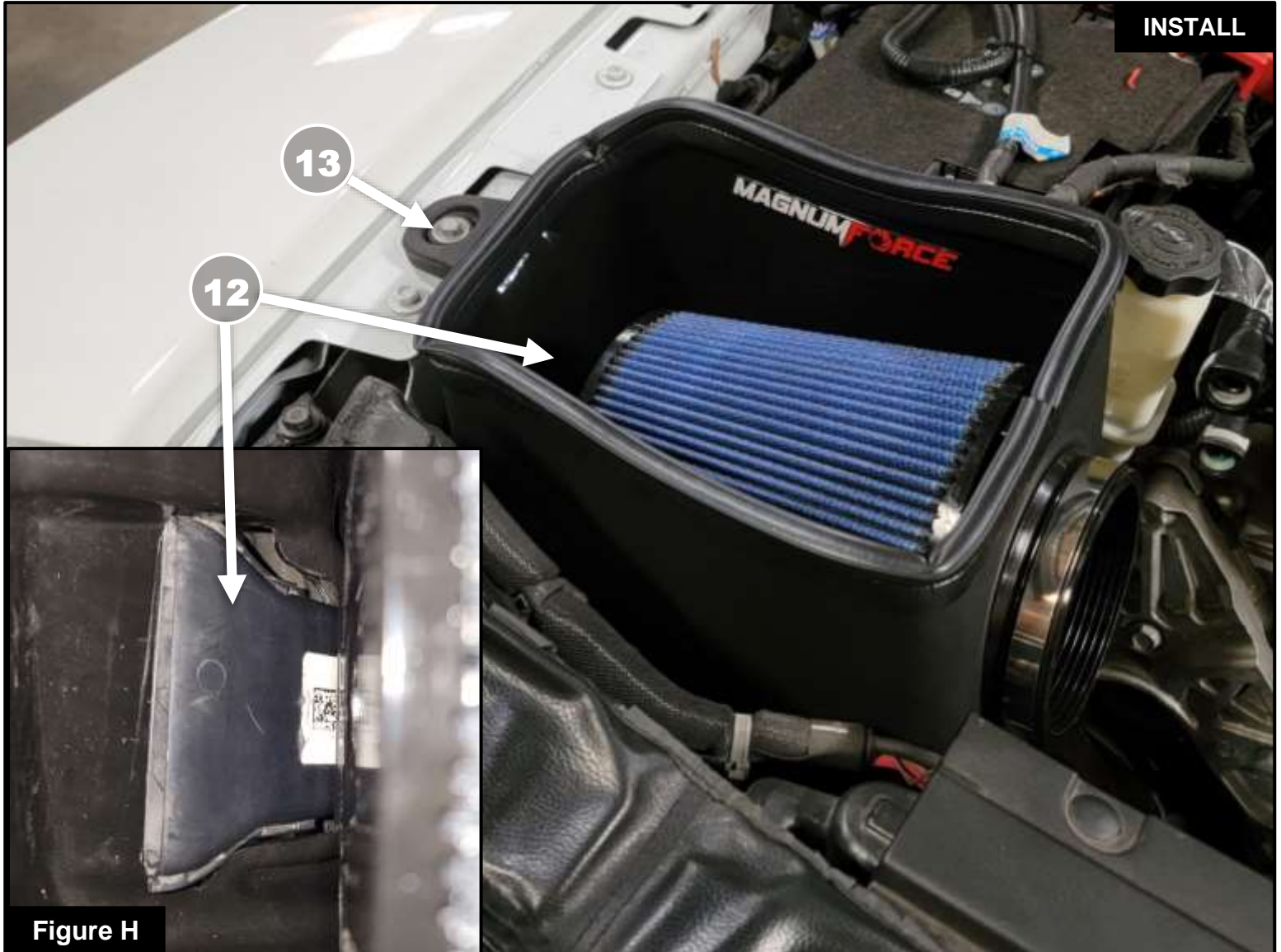

**Refer to Figure H for Steps 23-25**

**Step 23:** Install the housing into the vehicle and make sure that the factory intake scoop (12) passes into the housing under the air filter .

**Step 24:** Press down firmly on the housing to lock the pegs into the rubber grommets under the housing.

**Step 25:** Secure the housing to the fender with the factory screw (13) .



Figure I

**Refer to Figure I for Steps 26-28**

**Step 26:** Install the aFe POWER intake tube into the air filter first and then slide the coupler over the turbo inlet tube.

**Step 27:** Rotate the tube into position so that the mounting tabs sit flat on the fan shroud mounting brackets.

**Step 28:** Tighten all clamps at this time.

**Figure J****Refer to Figure J for Steps 29-30**

**Step 29:** Connect the IAT harness to the IAT sensor on the intake tube.

**Step 30:** Secure the IAT harness clip (14) into the radiator fan shroud as shown. It may be necessary to slide the clip further down on the wire so the wire is relaxed.

**Figure K****Refer to Figure K for Steps 31-32**

**Step 31:** Secure the intake tube to the fan shroud with the (2) two factory screws (15) .

**Step 32:** Reconnect the (2) two vent lines (16) to the new CCV Vacuum Fitting on the aFe POWER intake tube.



Figure L

**Refer to Figure L for Step 33**

**Step 33:** Check all the components are tight and secure. Your installation is now complete. Thank you for choosing aFe POWER!

**NOTE:** Check all screws, clamps, and connectors are secure after 100-200 miles.



advanced FLOW engineering, inc.  
252 Granite Street Corona, CA 92879  
<https://afepower.com/contact>