

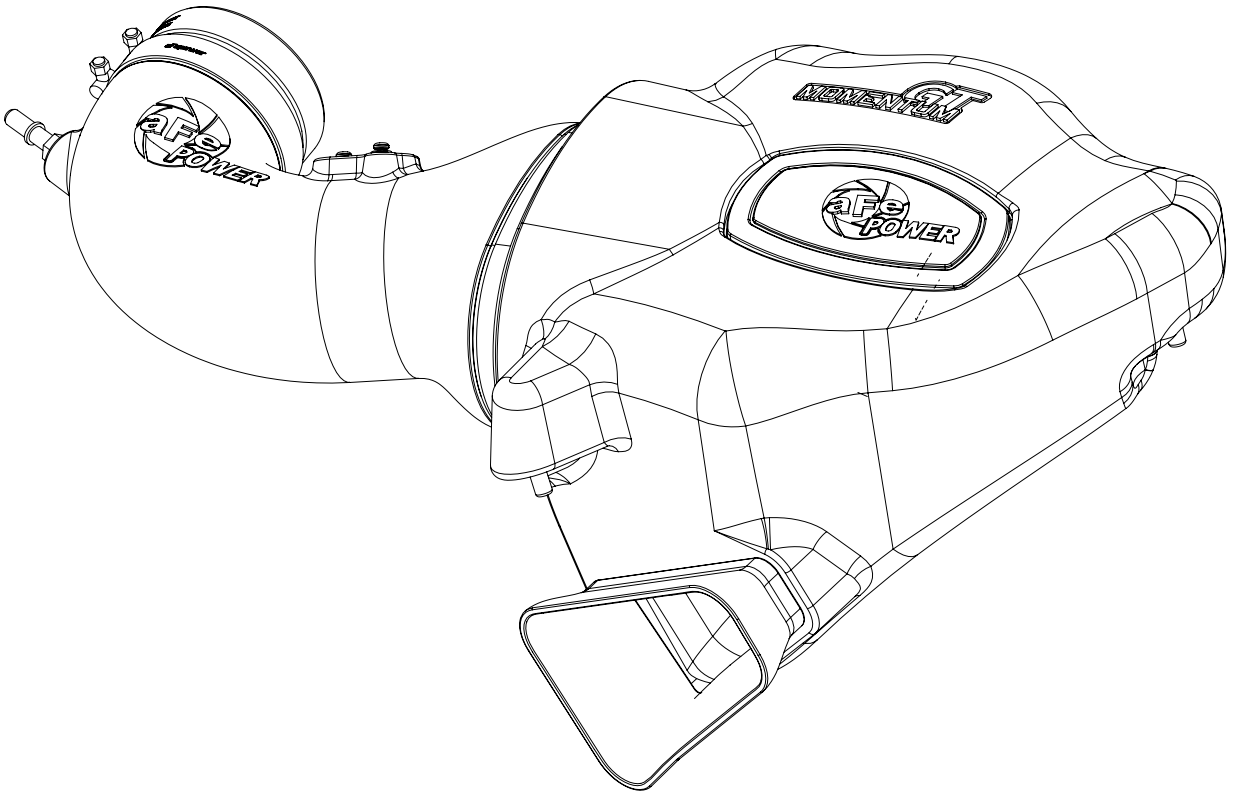

GT
MOMENTUM™



advanced FLOW engineering

Cold Air Intake System

Instruction Manual P/N: 51-74214 / 54-74214

Make: Chevrolet Model: Camaro ZL1 Year: 2017-2023 Engine: V8-6.2L (sc)



- Please read the entire instruction manual before proceeding.
- Ensure all components listed are present.
- If you are missing any of the components, call customer support at 951-493-7185.
- Ensure you have all necessary tools before proceeding.
- Do not attempt to work on your vehicle when the engine is hot.



Retain factory parts for future use.

Label	Qty.	Description	Part Number
A1	1	Air Filter (Pro 5R)	24-91092
A2	1	Air Filter (Pro DRY S)	21-91092
B	1	Tube	05-74214B1
C	1	Housing	05-74210B2
D	1	Clamp, T-bolt (3-13/16" - 4-1/8")	03-50265
E	1	Coupling, Silicone Reducer	05-01463
F	1	Fitting, Vent	05-01692
G	1	Clamp, T-bolt (4-1/16" - 4-3/8")	03-50262
H	2	Screw, M4	03-50491
I	1	Plug, Urethane	05-00937
J	1	Scoop	05-74210B3

Installation will require the following tools:

8mm nut driver, 11mm deep socket & driver, T20 Torx, 15mm wrench or adjustable wrench.

Warranty Information available at: <https://afepower.com/contact#warranty>

Emission Disclaimer: This system is not currently CARB exempt and is not available for sale in California or for use on any vehicle registered with the California Department of Motor Vehicle.

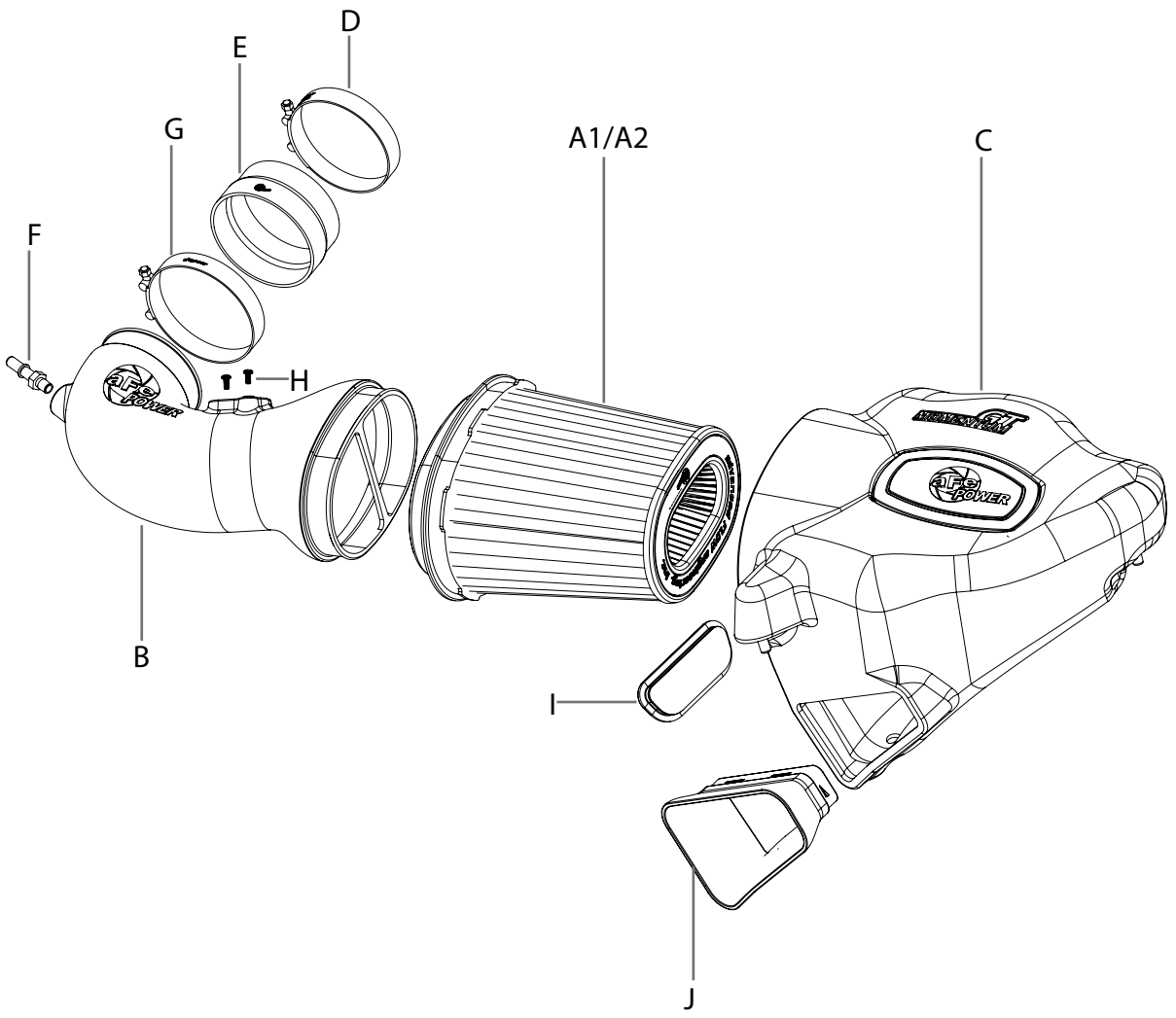

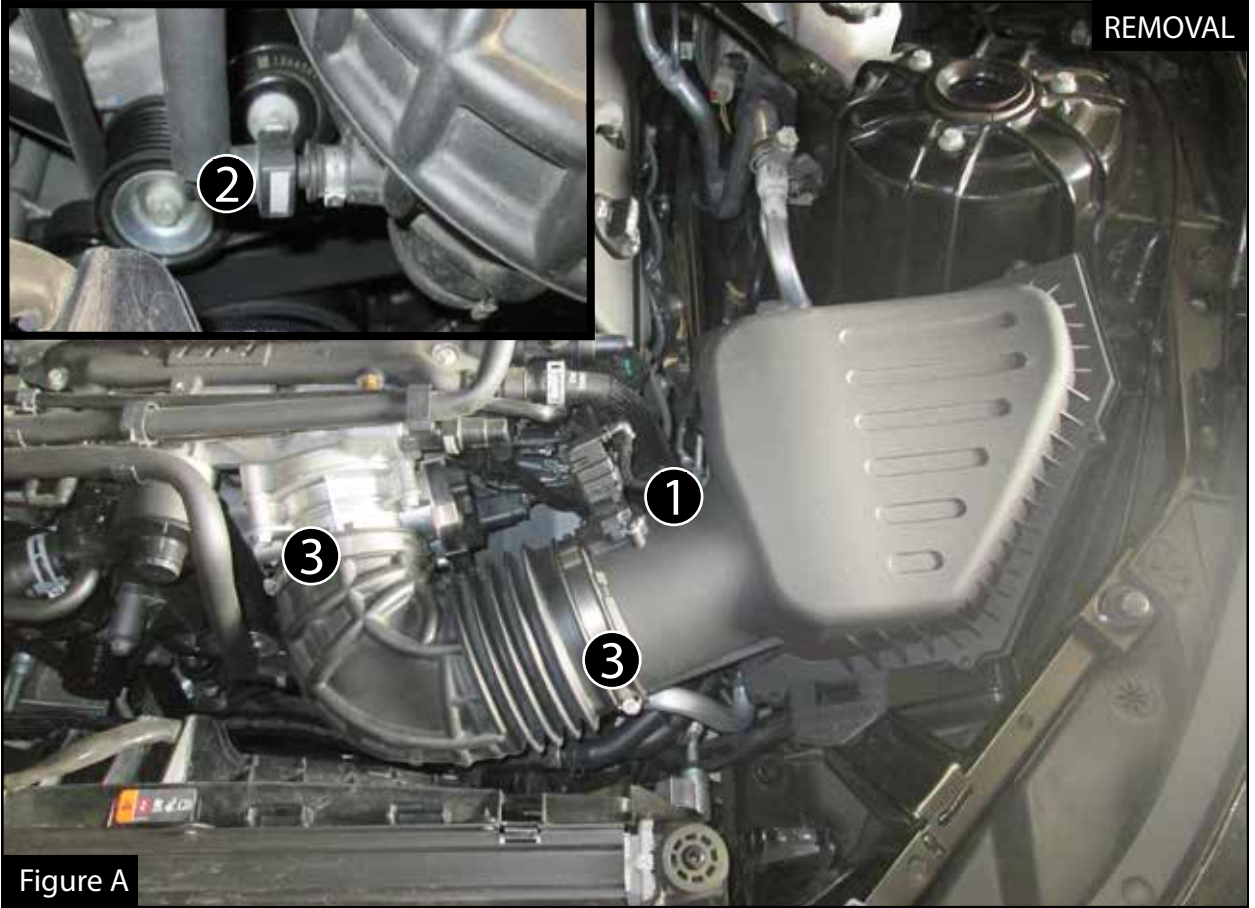

Refer to Figure A for Steps 1-2

Step 1: Disconnect the MAF **1** sensor and breather hose **2** from the intake tube.

Step 2: Use an 8mm nut driver to loosen the stock clamps **3** at the throttle body and the airbox.

Remove the stock intake tube.

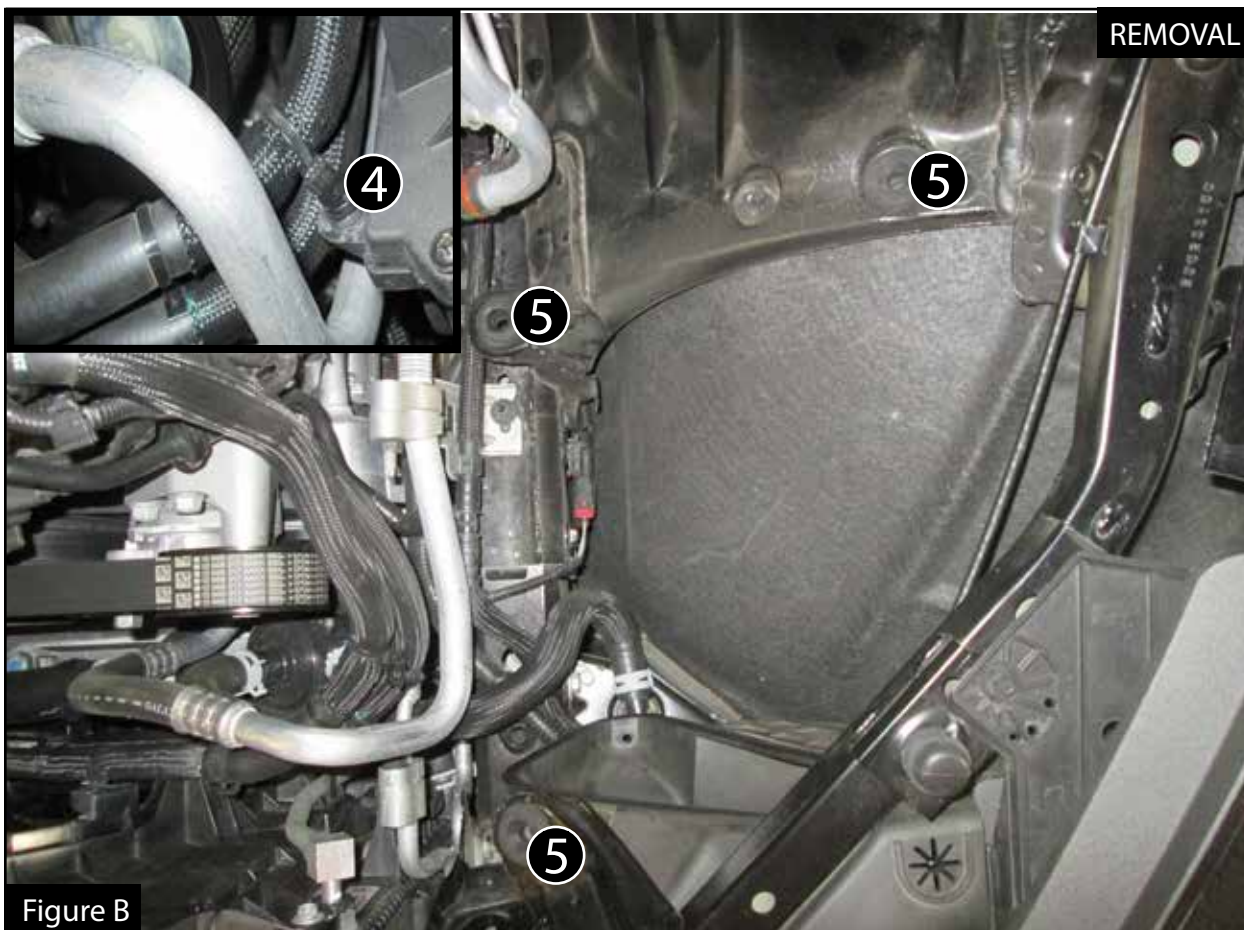

Figure B

Refer to Figure B for Steps 3-4

Step 3: Remove the clip (4) holding the coolant line to the airbox.

Step 4: Remove the airbox by pulling up to release airbox from its mounting grommets (5). Make sure the mounting grommets (5) are still in the chassis mounting tabs. If they pulled out and are stuck in the lower half of the airbox, remove them from the airbox and insert them back on the chassis mounting tabs.



Figure C

Refer to Figure C for Steps 5-6

Step 5: Install the supplied air inlet scoop (6) into the aFe airbox.

Step 6: Use the provided plug (7) to close the additional air inlet if you want to completely seal the airbox. Best performance gain is obtained by having more air flow (no plug).



Figure D

Refer to Figure D for Step 7

Step 7: Slide the aFe filter and clamp into the aFe housing and push it in until it locks into place. Do not tighten the clamp at this time.



Refer to Figure F for Steps 8-9

Step 8: Using a Torx T20 driver, remove the mass air flow sensor (8) from the upper half of the airbox and install it into the aFe intake tube using the two provided torx screws.

Step 9: Install the supplied aluminum vent fitting (9) into the aFe intake tube using a 15mm wrench or adjustable wrench.



Figure F

Refer to Figure F for Step 10

Step 10: Install the aFe intake tube into the air filter. Do not tighten the clamp at this time.



Refer to Figure G for Step 11

Step 11: Install the reducer silicone coupler (10) onto the throttle body with the provided smaller T-bolt clamp (11) and tighten.



Figure H

Refer to Figure H for Step 12

Step 12: Install the supplied larger T-bolt clamp onto the coupler at the throttle body. Do not tighten clamp.



Figure I

Refer to Figure I for Steps 13-14

Step 13: Install the intake assembly into the vehicle by sliding the intake tube into the coupler then pushing down housing mounting pins into the rubber grommets. Make sure the pins are completely through the mounting grommets.

Step 14: Connect the mass air flow sensor (12) and breather hose (13). Check all the components are aligned correctly, and tighten all clamps. (As shown in picture)



Figure J

Refer to Figure J for Step 15

Step 15: Your installation is now complete.

NOTE: Check all bolts, clamps, and connectors after 100-200 miles.



PAGE LEFT BLANK INTENTIONALLY

PAGE LEFT BLANK INTENTIONALLY



advanced FLOW engineering, inc.

Corona, CA 92879

<https://afepower.com/contact>