

advanced FLOW engineering

Instruction Manual P/N: 56-10055D / 56-10055R

Cold Air Intake System

Make: **Kia**

Model: **Stinger**

Year: **2018-2021**

Engine: **L4-2.0L(t)**



- Please read the entire instruction manual before proceeding.
- Ensure all components listed are present.
- For technical support please call 951-493-7185.
- Ensure you have all necessary tools before proceeding.
- Do not attempt to work on your vehicle when the engine is hot.
- Retain factory parts for future use.

Label	Qty.	Description	Part Number
A	1	Air Filter (Pro 5R)	24-90114
A	1	Air Filter (Pro DRY S)	21-90114
B	1	Tube	05-5670055B1
C	1	Housing	05-5610060B2
D	1	Seal trim (37" Long)	05-01507
E	1	Coupling, Silicone Elbow Rdr: (3"x2-1/2")IDx 35Deg	05-01421
F	1	Clamp, 044 (2-5/16" - 3-1/4")	03-50019
G	1	Clamp, 048 (2-9/16" - 3-1/2")	03-50007
H	1	Fitting, 12mm Barbed (Five-barb) to 1/8" NPT	03-50824
J	1	Fitting, 11mm Barbed (Four-Barb) to 1/8" NPT	03-50615

Installation will require the following tools:

Pliers, Channel lock pliers, 10mm open end wrench, flat head screwdriver, 8mm nut driver, Socket wrench and extensions, 10mm socket, 12mm socket, 16mm socket

Warranty Information available at <https://afepower.com/contact#warranty>

Emissions Disclaimer: This product is not currently CARB exempt and is not available for purchase in California or for use on any vehicle registered with the California Department of Motor Vehicles.

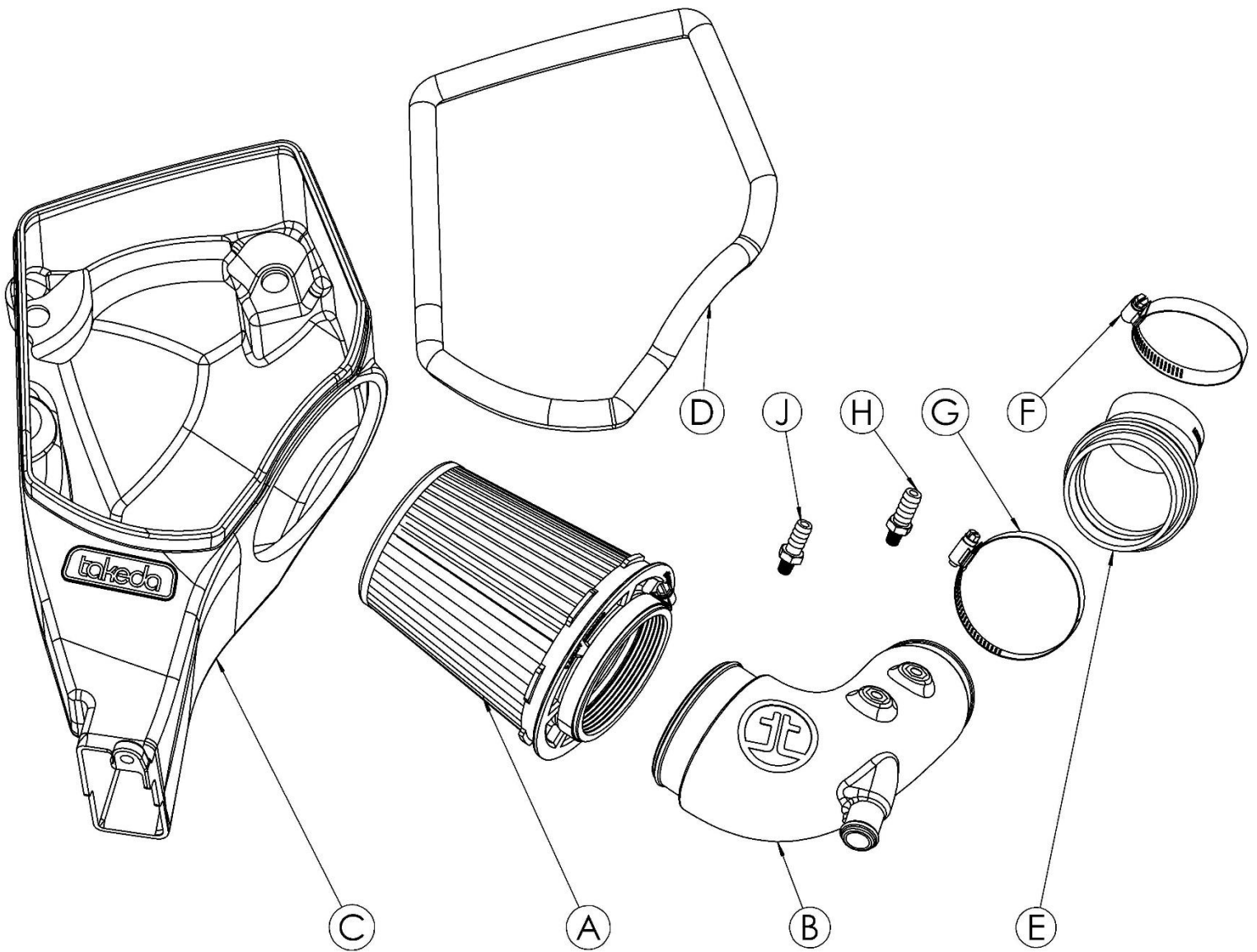



Figure A

Refer to Figure A for Step 1

Step 1: Undo the two 12mm bolts ① and remove the factory brace.

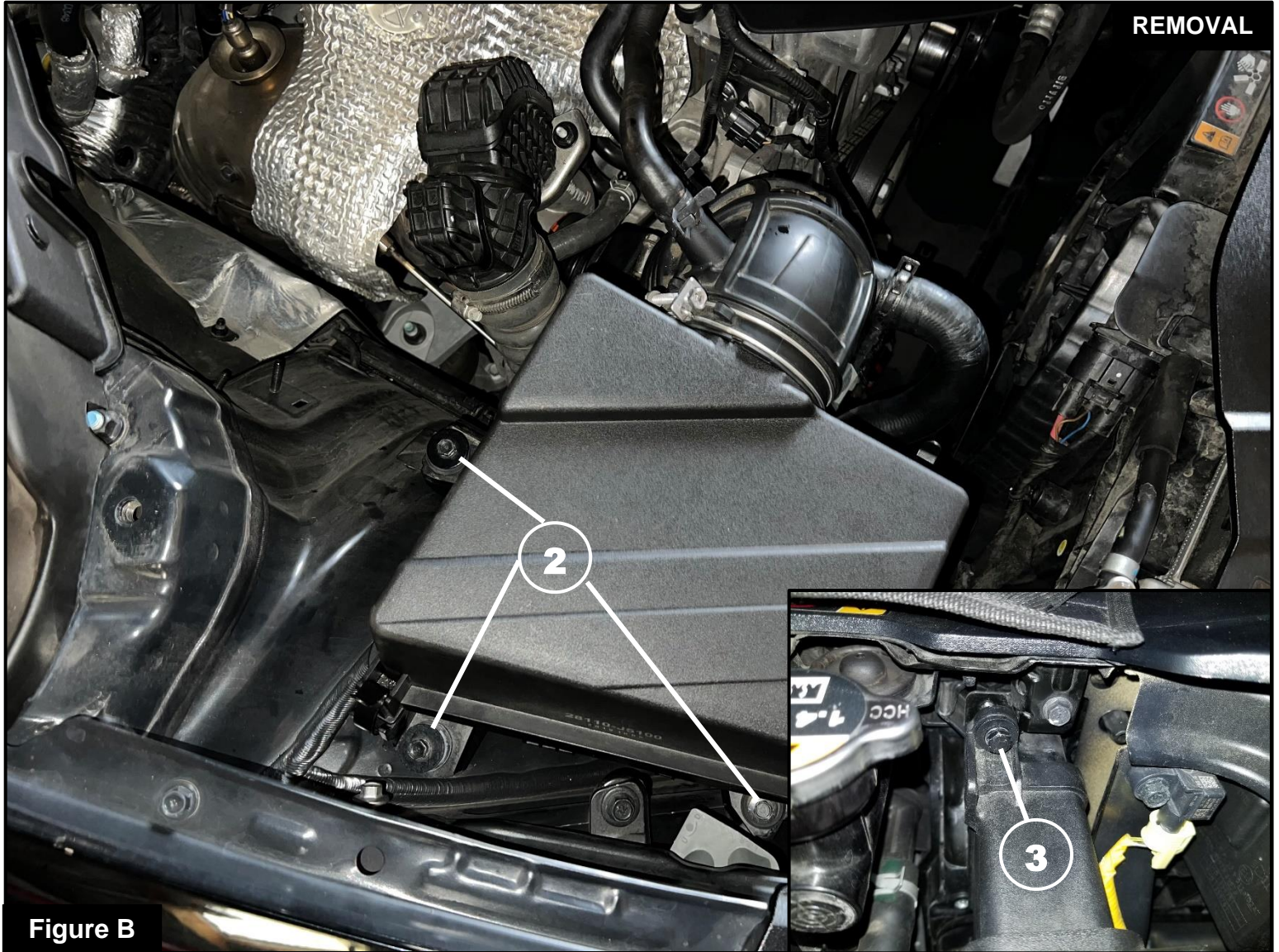

Figure B

Refer to Figure B for Step 2

Step 2: Using a 10mm socket, remove the three screws (2) securing the airbox as well as the two screws attaching the top and bottom of the inlet (3). Keep for later use.

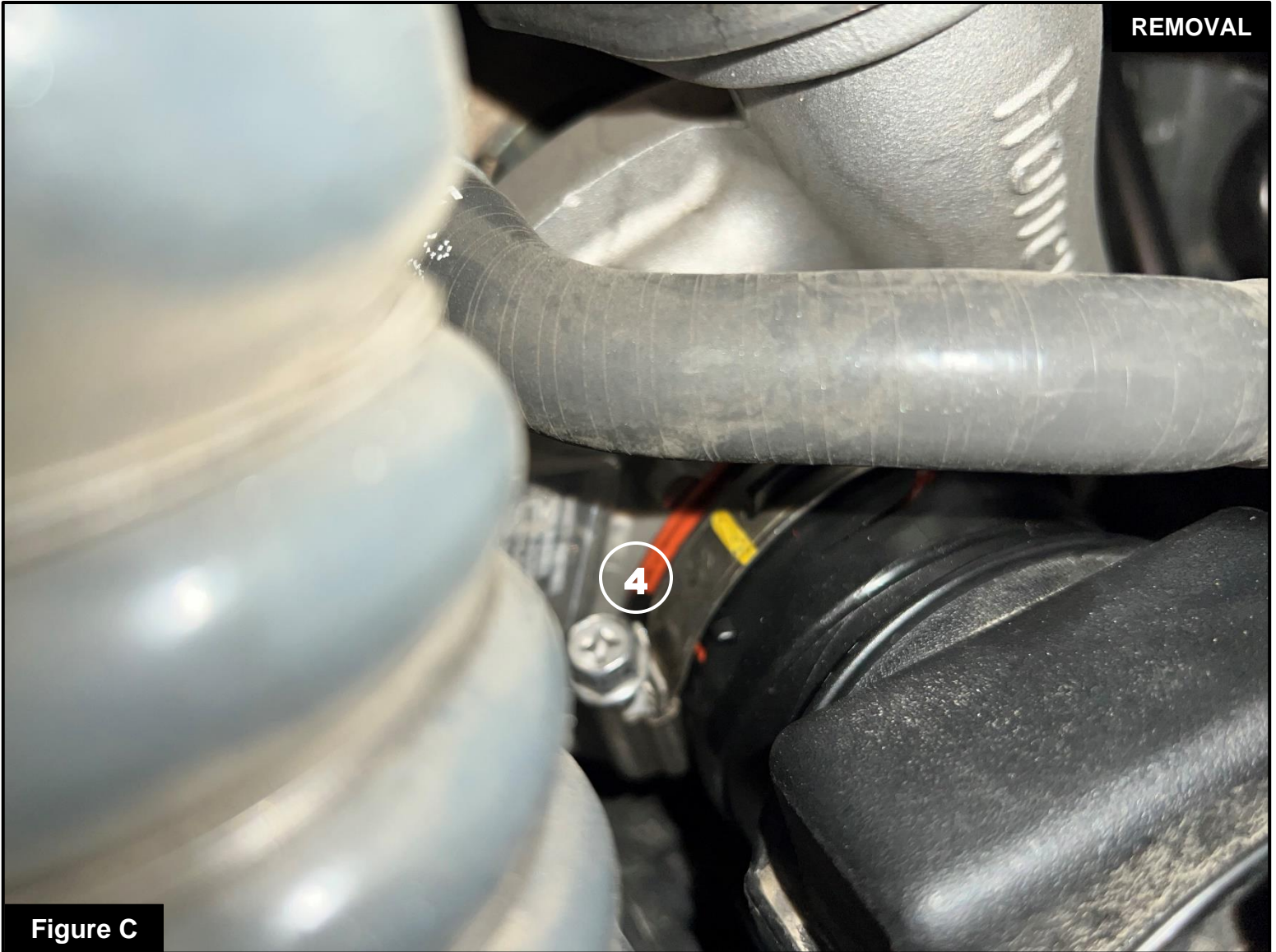

Figure C

Refer to Figure C for Step 3

Step 3: Loosen the clamp ④ that secures the OE intake tube to the turbo inlet.

**Figure D****Refer to Figure D for Steps 4-5**

Step 4: Using pliers squeeze both sides of the clamps (5) to release them. Then remove vacuum lines from factory tube.

Step 5: You can now remove the airbox, tube, and inlet as one piece.



Figure E

Refer to Figure F for Step 6

Step 6: Transfer two of the gromets ⑦ from the OEM airbox to the new Takeda housing.



Figure F

Refer to Figure F for Step 7

Step 7: Install provided seal trim onto Takeda housing.

**Figure G****Refer to Figure G for Steps 8-10**

Step 8: Thread the five-barb fitting (9) into the tube as shown.

Step 9: Thread the supplied four-barb fitting (10) into the tube as shown.

Step 10: Tighten both fittings using a 16mm wrench or deep socket. **DO NOT OVER TIGHTEN. SPACE BETWEEN THE 16MM HEX AND TUBE IS NORMAL.**

INSTALL

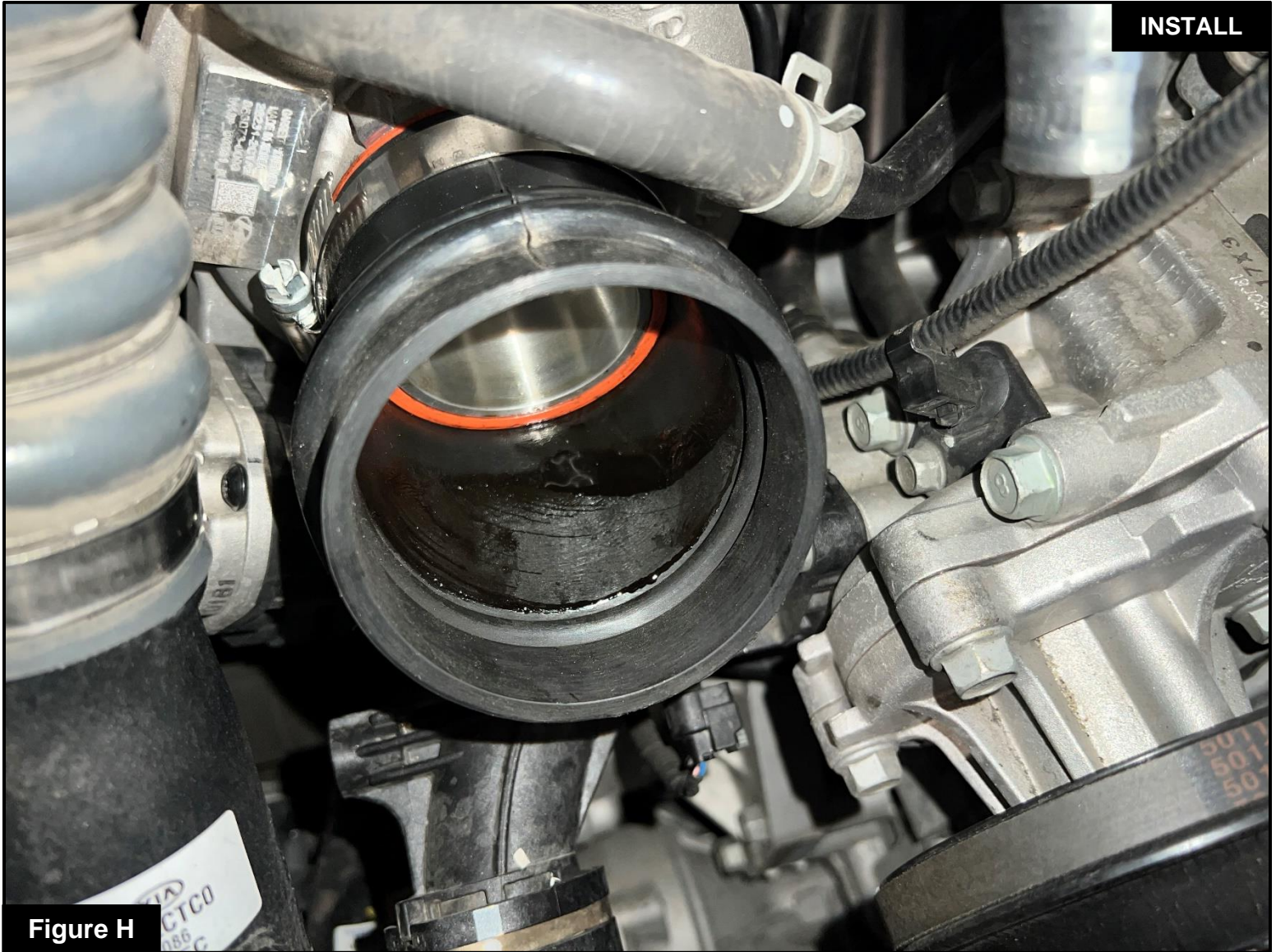

Figure H

Refer to Figure H for Step 11

Step 11: Install the supplied coupling to the turbo inlet and secure it using one of the provided clamps.



Figure I

Refer to Figure I for Step 12

Step 12: Install the Takeda housing into the engine bay and secure it using screws ② and ③ removed in **Step 2**. Ensure that these screws correspond to the location they were removed from.



Figure J

Refer to Figure J for Steps 13

Step 13: Install the air filter into the housing by firmly pushing it into the housing until the filter tabs lock it into place.



Figure K

Refer to Figure K for Steps 14-15

Step 14: Install the Takeda tube by first inserting it into the coupling on the turbo inlet, followed by inserting the tube into the filter. To ensure the Takeda tube is clocked correctly, feel for any gaps between the tube and filter. Tighten all clamps.

Step 15: Attach the three hoses removed in **Step 4** to the tube as shown and secure them with the spring clamps.

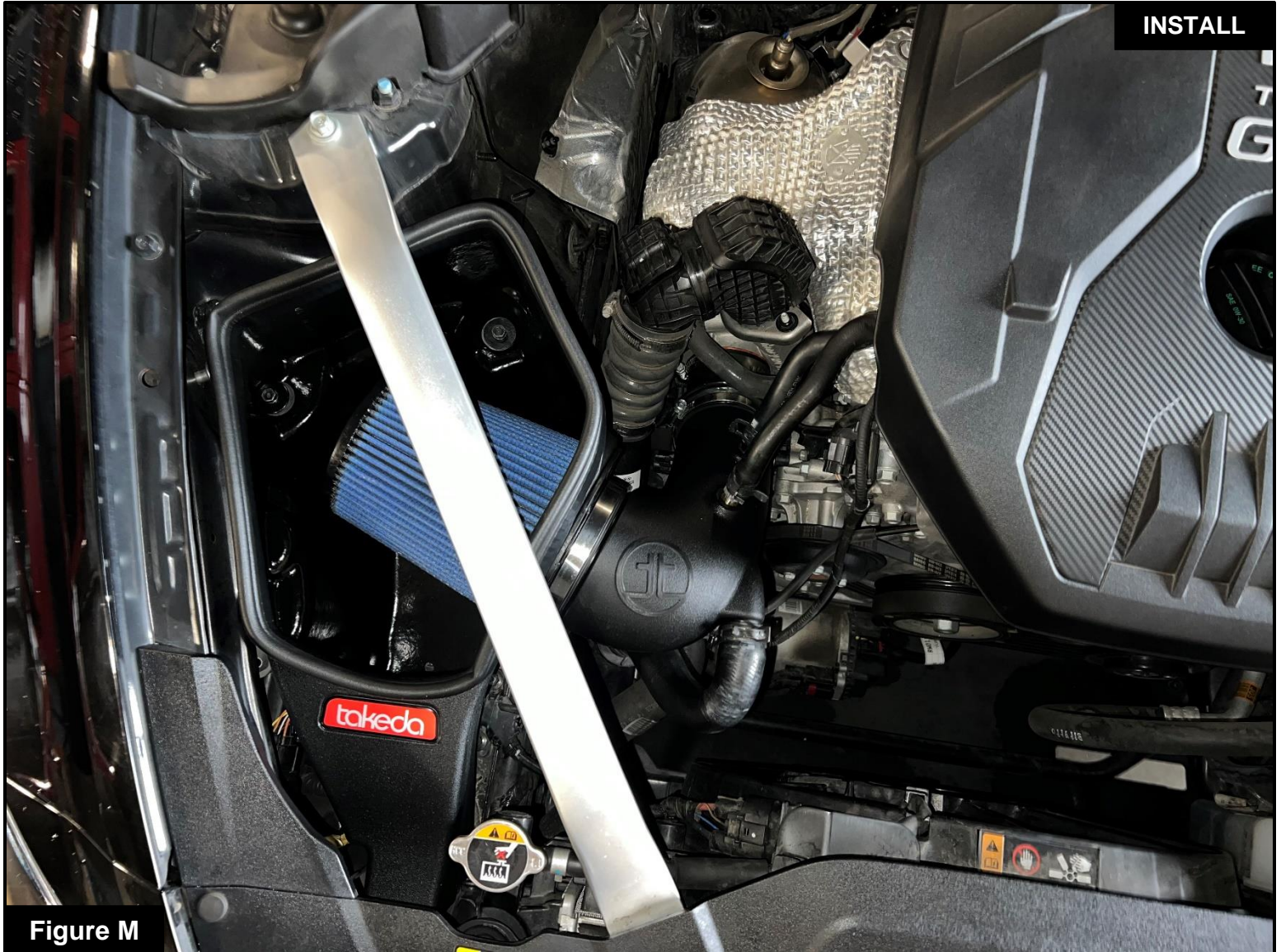

Figure M

Refer to Figure M for Steps 16-17

Step 16: Reattach the brace removed in **Step 1**.

Step 17: Make sure that all clamps and connections are secured. Your installation is now complete. Thank you for choosing Takeda USA!

NOTE: Check to ensure that all screws, clamps, and connectors are secured after 100-200 miles.



advanced FLOW engineering, inc.

Corona, CA 92879

<https://afepower.com/contact>