

advanced FLOW engineering

Instruction Manual P/N: 56-10060D / 56-10060R

Cold Air Intake System

Make: Kia

Model: Stinger

Year: 2022-2023

Engine: L4-2.5L(t)



- Please read the entire instruction manual before proceeding.
- Ensure all components listed are present.
- For technical support please call 951-493-7185.
- Ensure you have all necessary tools before proceeding.
- Do not attempt to work on your vehicle when the engine is hot.
- Retain factory parts for future use.

Label	Qty.	Description	Part Number
A	1	Air Filter (Pro 5R)	24-90114
A	1	Air Filter (Pro DRY S)	21-90114
B	1	Tube	05-5670060B1
C	1	Housing	05-5610060B2
D	1	Seal trim (37" Long)	05-01507
E	1	Coupling, Bellows: 3-3/32"ID x 3"L w/ IB	05-01525
F	2	Clamp, 048 (2-9/16" - 3-1/2 ")	03-50007
G	1	Fitting, 11mm Barbed (Four-barb) to 1/8" NPT	03-50615
H	1	Fitting, 12mm Barbed (Five-Barb) to 1/8" NPT	03-50824
J	1	Insert, Vent Tube	03-50833

Installation will require the following tools:

Pliers, Channel lock pliers, 10mm open end wrench, flat head screwdriver, 8mm nut driver, Socket wrench and extensions, 10mm socket, 16mm socket

Warranty Information available at <https://afepower.com/contact#warranty>

Emissions Disclaimer: This product is not currently CARB exempt and is not available for purchase in California or for use on any vehicle registered with the California Department of Motor Vehicles.

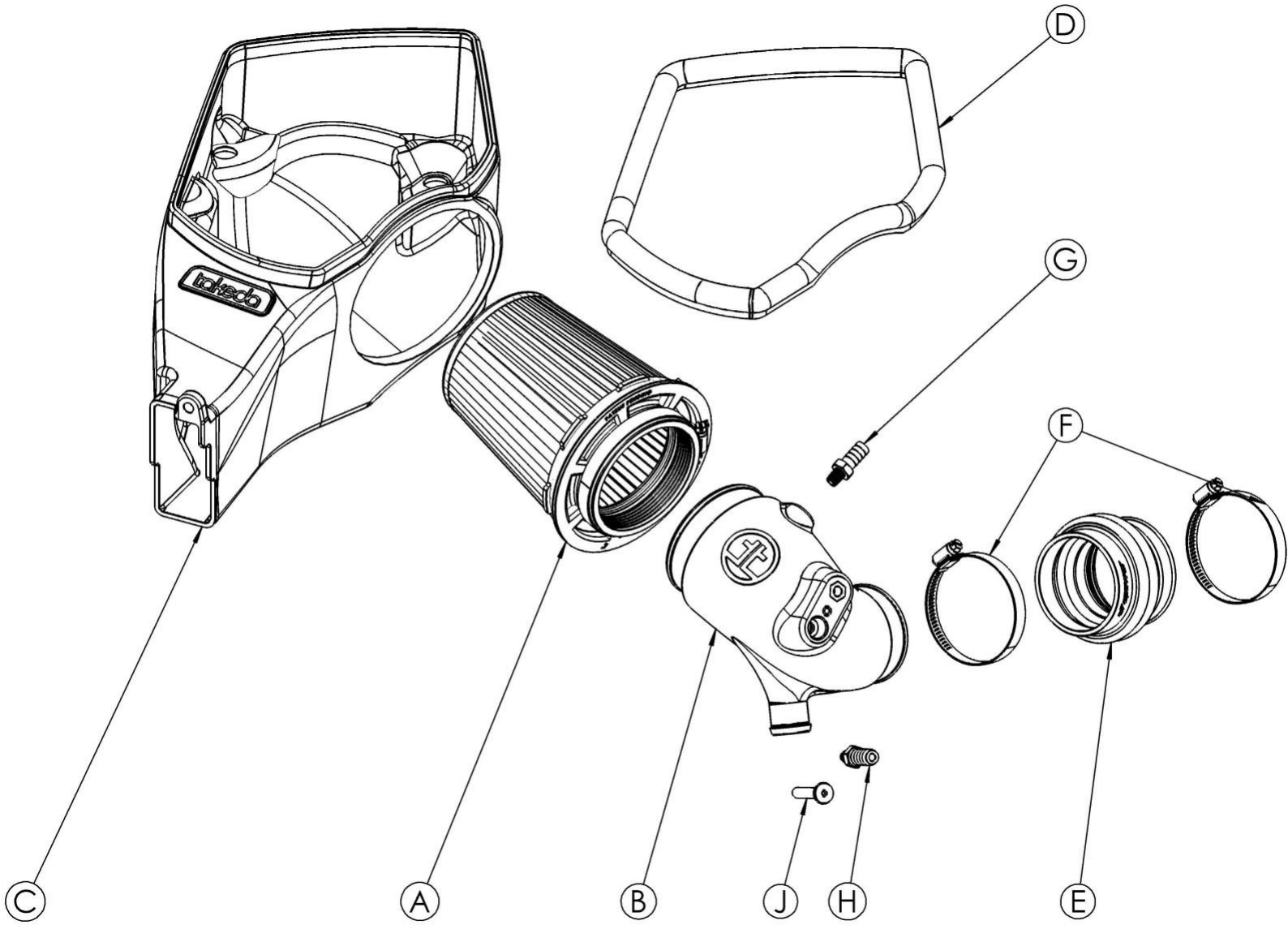



Figure A

Refer to Figure A for Step 1

Step 1: Undo the two 12mm bolts (1) and remove the factory brace.

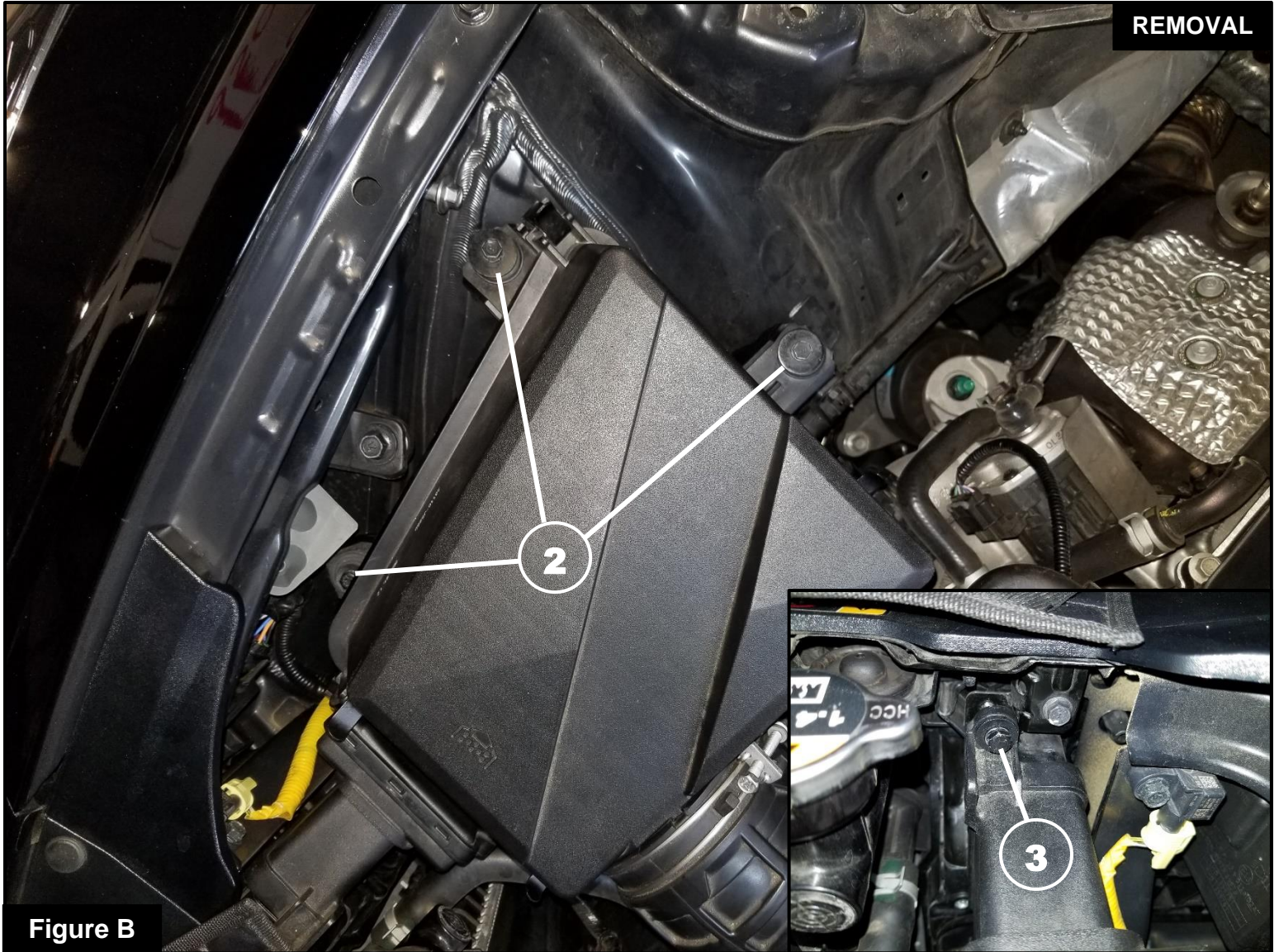

Figure B

Refer to Figure B for Step 2

Step 2: Using a 10mm socket, remove the three screws ② securing the airbox as well as the two screws attaching the top and bottom of the inlet ③.

**Figure C****Refer to Figure C for Step 3**

Step 3: Locate the clip that secures the OE intake tube to the turbo inlet. Press both ends of the clip ④ outward and lock them in place.

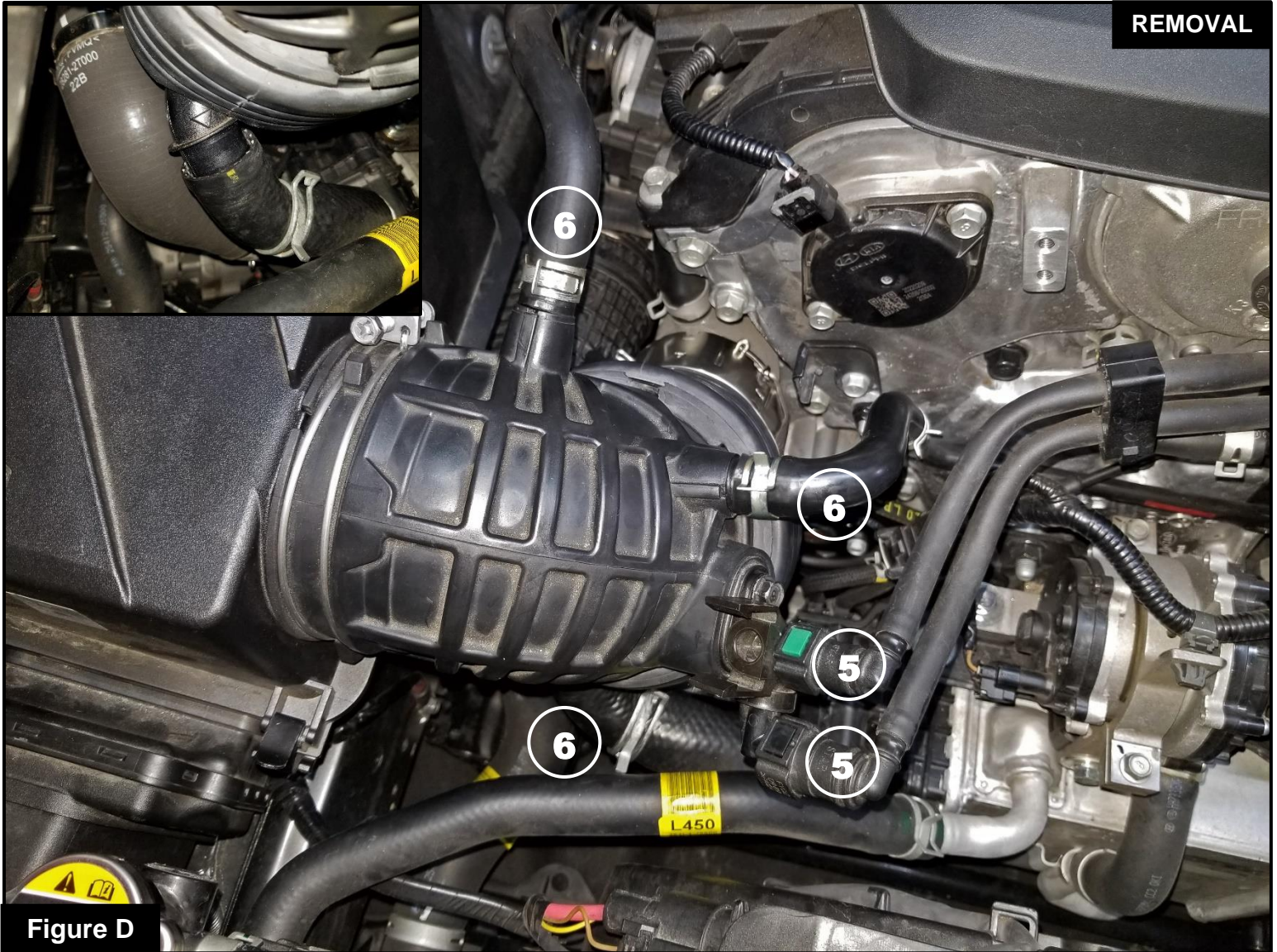

Refer to Figure D for Steps 4-6

Step 4: Squeeze both sides of the vacuum line clips (5) to release them. Then remove them from the vacuum port.

Step 5: Pull the three spring clamps (6) back on their respective hoses and remove the hoses from the tube.

Step 6: You can now remove the airbox, tube, and inlet as one piece.



Figure E

Refer to Figure E for Step 7

Step 7: Transfer two of the gromets ⑦ from the OEM airbox to the new Takeda housing.



Figure F

Refer to Figure F for Steps 8-9

Step 8: Install the air filter into the housing by firmly pushing it into the housing until the filter tabs lock it into place.

Step 9: Install the provided seal trim around the top edges of the airbox.



Figure G

Refer to Figure G for Step 10

Step 10: Install the included aluminum vent tube into the Takeda tube as shown.

Figure H

Refer to Figure H for Steps 11-14

Step 11: Using an 8mm nut driver, remove the screw holding the vacuum port (8) to the OEM intake tube and transfer it to the Takeda tube. Secure it with the same screw.

Step 12: Thread the five-barb fitting (9) into the threads adjacent to the vacuum port.

Step 13: Thread the supplied four-barb fitting (10) into the tube as shown.

Step 14: Tighten both fittings using a 16mm wrench or deep socket. **DO NOT OVER TIGHTEN. SPACE BETWEEN THE 16MM HEX AND TUBE IS NORMAL.**



Refer to Figure I for Step 15

Step 15: Install the supplied coupling to the turbo inlet and secure it using one of the provided clamps. Ensure the interior lip of the coupling is seated properly before tightening the clamp.

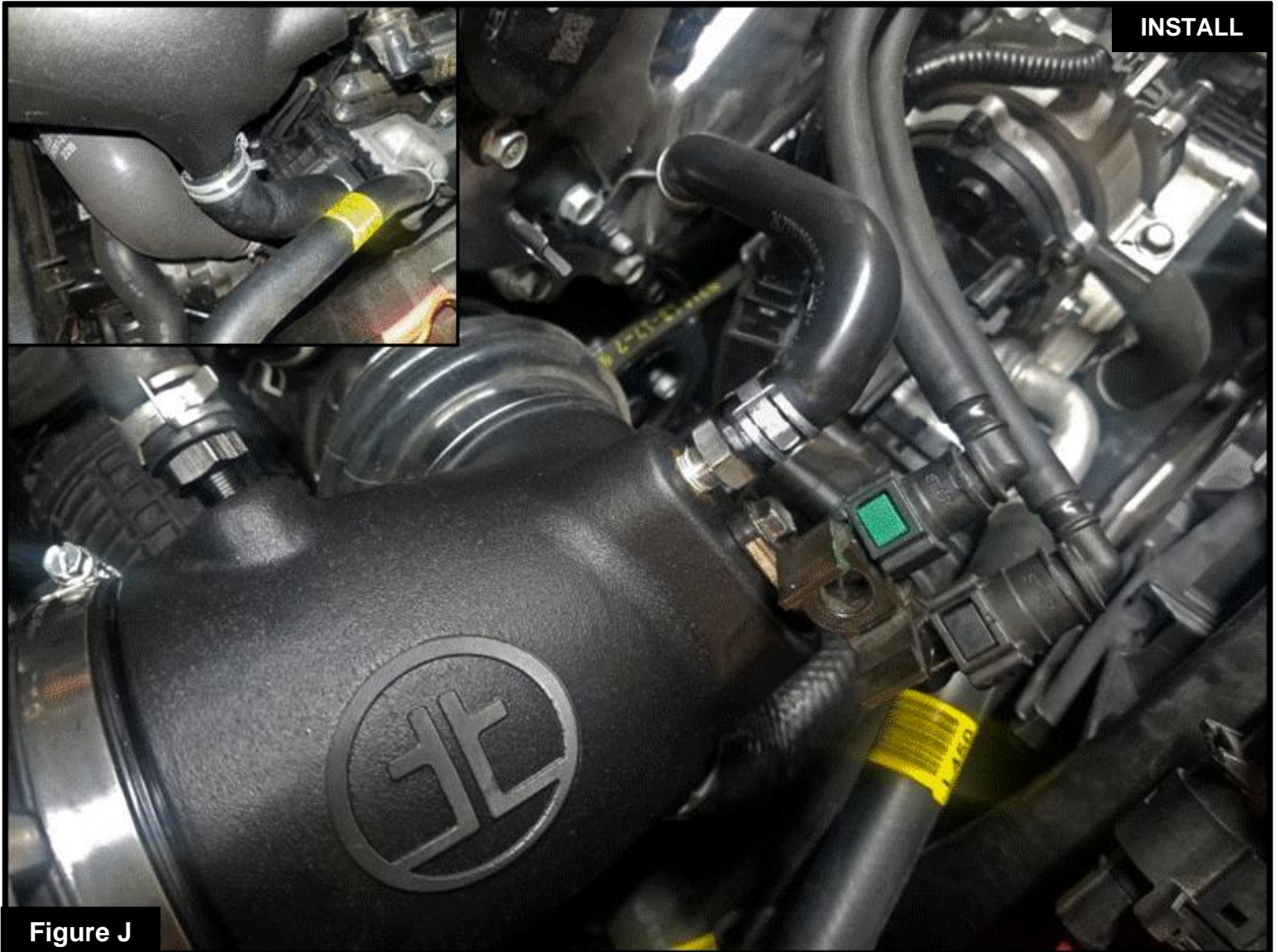

Figure J

Refer to Figure J for Steps 16-18

Step 16: Install the Takeda tube by inserting it into the coupling. Do not tighten the clamp at this time.

Step 17: Clip the vacuum lines back onto the port.

Step 18: Attach the three hoses removed in **Step 5** to the tube as shown and secure them with the spring clamps.

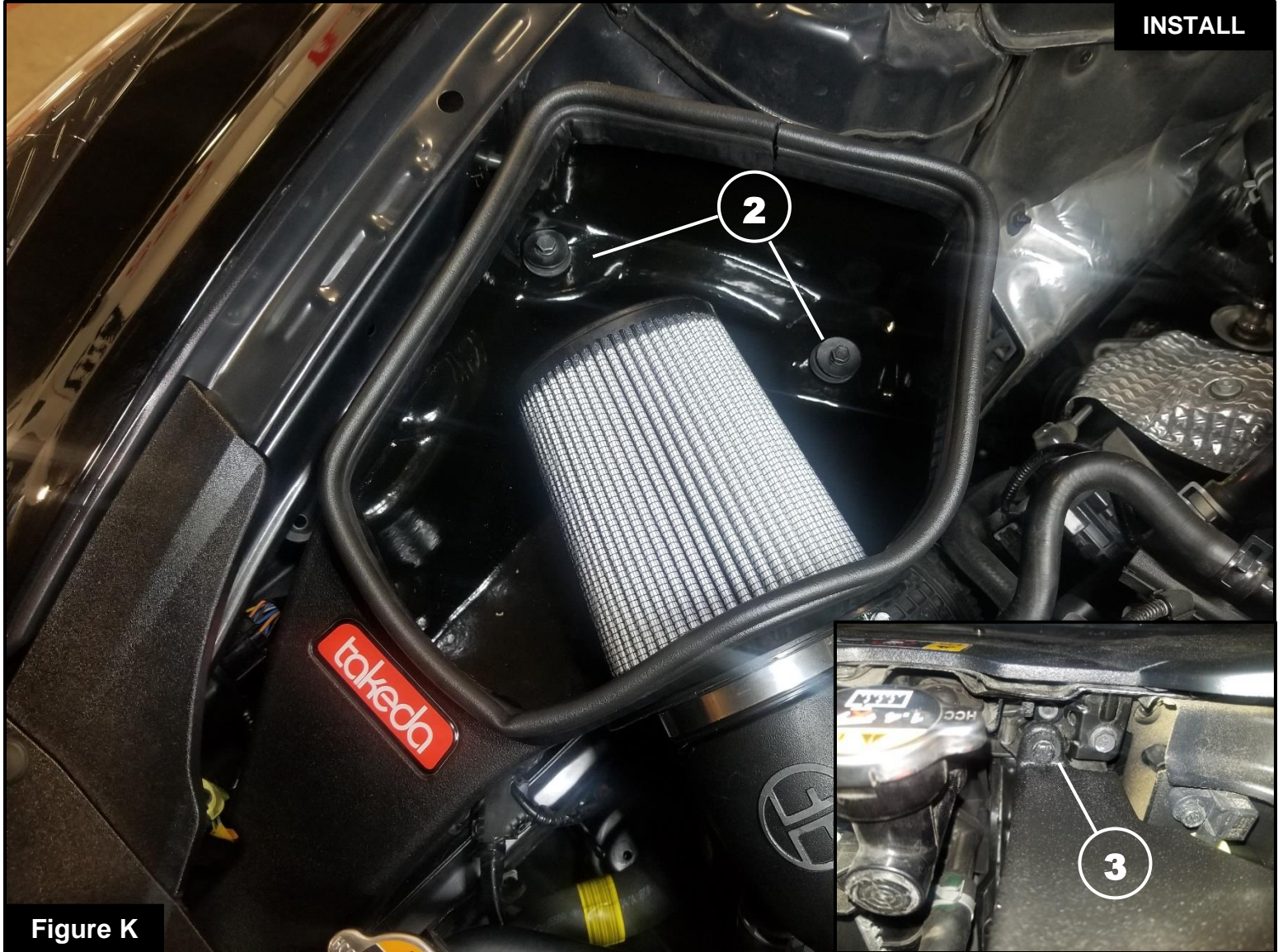
**Figure K****Refer to Figure K for Step 19**

Step 19: Install the Takeda housing into the engine bay by connecting the filter to the Takeda tube and then lining up the mounting holes. Secure the housing using screws ② and ③ removed in **Step 2**. Ensure that these screws correspond to the location they were removed from.

**Figure L****Refer to Figure L for Steps 20-21**

Step 20: Reattach the brace removed in **Step 1**.

Step 21: Make sure that all clamps and connections are secured. Your installation is now complete. Thank you for choosing Takeda USA!

NOTE: Check to ensure that all screws, clamps, and connectors are secured after 100-200 miles.



advanced FLOW engineering, inc.

Corona, CA 92879

<https://afepower.com/contact>