

advanced FLOW engineering Takeda Momentum Cold Air Intake System

Instruction Manual P/N: 56-70048D / 56-70048R

Make: Ford

Model: Fiesta S, SE, Titanium

Year: 2014-2019

Engine: I4-1.6L



- Please read the entire instruction manual before proceeding.
- Ensure all components listed are present.
- If you are missing any of the components, call customer support at 951-493-7134.
- Ensure you have all necessary tools before proceeding.
- Do not attempt to work on your vehicle when the engine is hot.
- Retain factory parts for future use.

Label	Qty.	Description	Part Number
A1	1	Air Filter (Pro 5R)	TF-9029R
A2	1	Air Filter (Pro DRY S)	TF-9029D
B	1	Silicone Tube	05-5670048B1
C	1	Housing	05-5670041B2
D	1	Fitting, Coupling	03-50748
E	1	Clamp, 032 (1-9/16" -2-1/2")	03-50016
F	1	Breather Filter	18-01005
G	1	Fitting, Crankcase Vent	05-01696
H	1	Plug, Silicone Black: 2.25" Dia (Takeda)	05-01527

Installation will require the following tools:

7mm and 8mm nut drivers, small flat blade screwdriver

Warranty Information available at <https://afepower.com/contact#warranty>

Emissions Disclaimer: This product is not currently CARB exempt and is not available for purchase in California or for use on any vehicle registered with the California Department of Motor Vehicles.

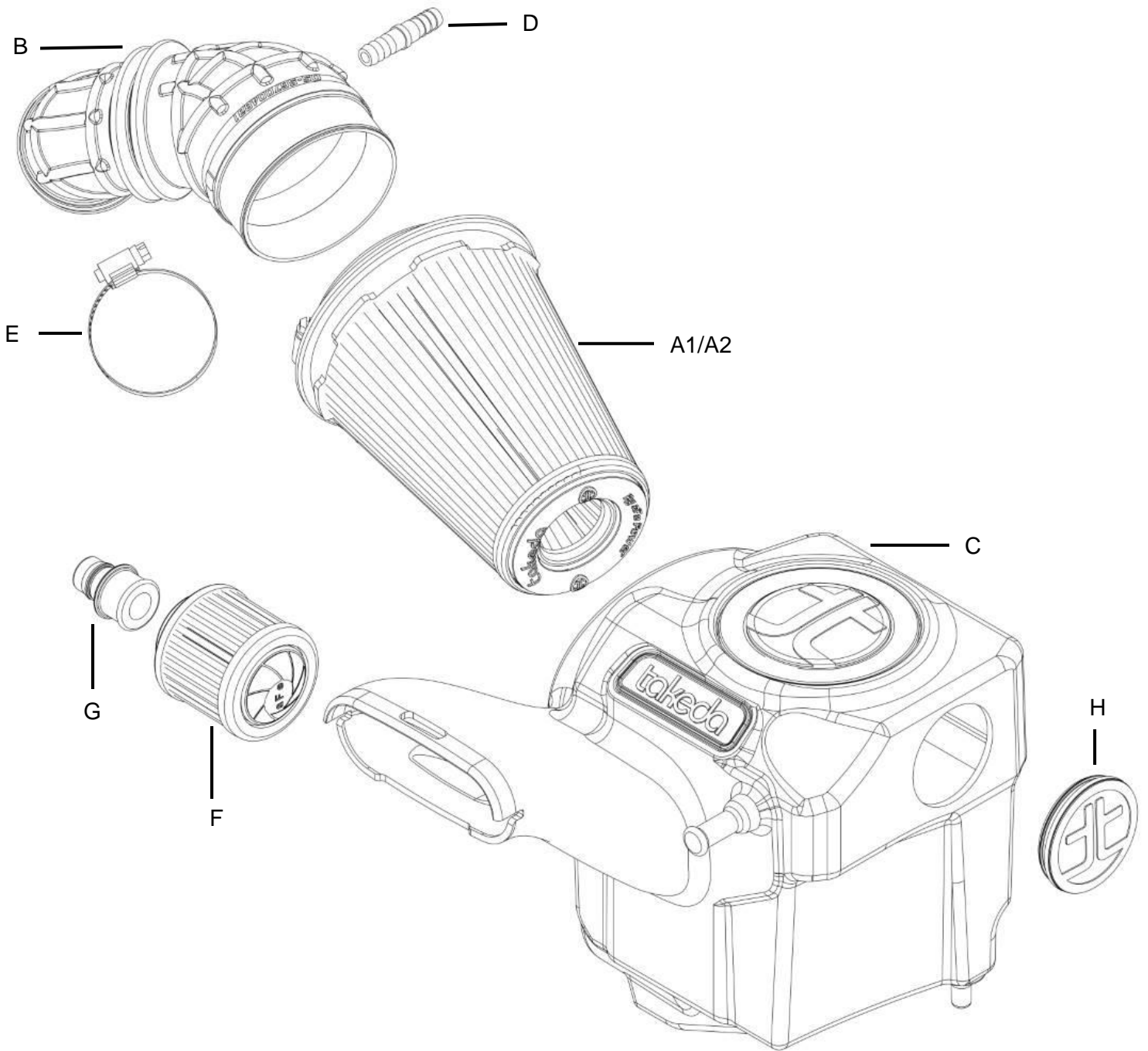

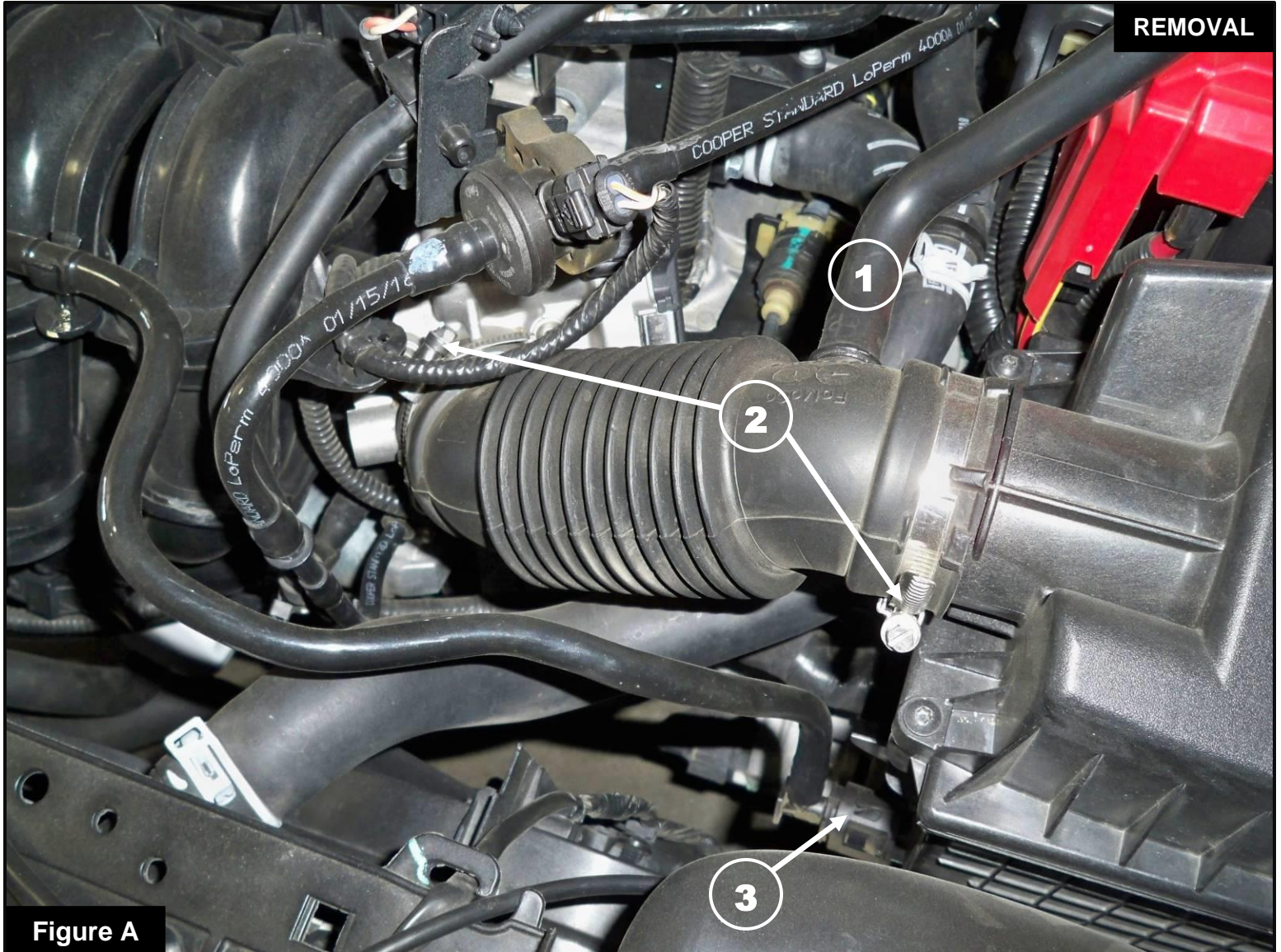

Refer to Figure A for Steps 1-4

- Step 1: Disconnect the vacuum hose ① from the stock intake tube .
- Step 2: Using a 7mm nut driver, loosen the stock clamps ② at the throttle body and at the airbox.
- Step 3: Remove the stock intake tube.
- Step 4: Disconnect the crankcase vent line ③ from the airbox.

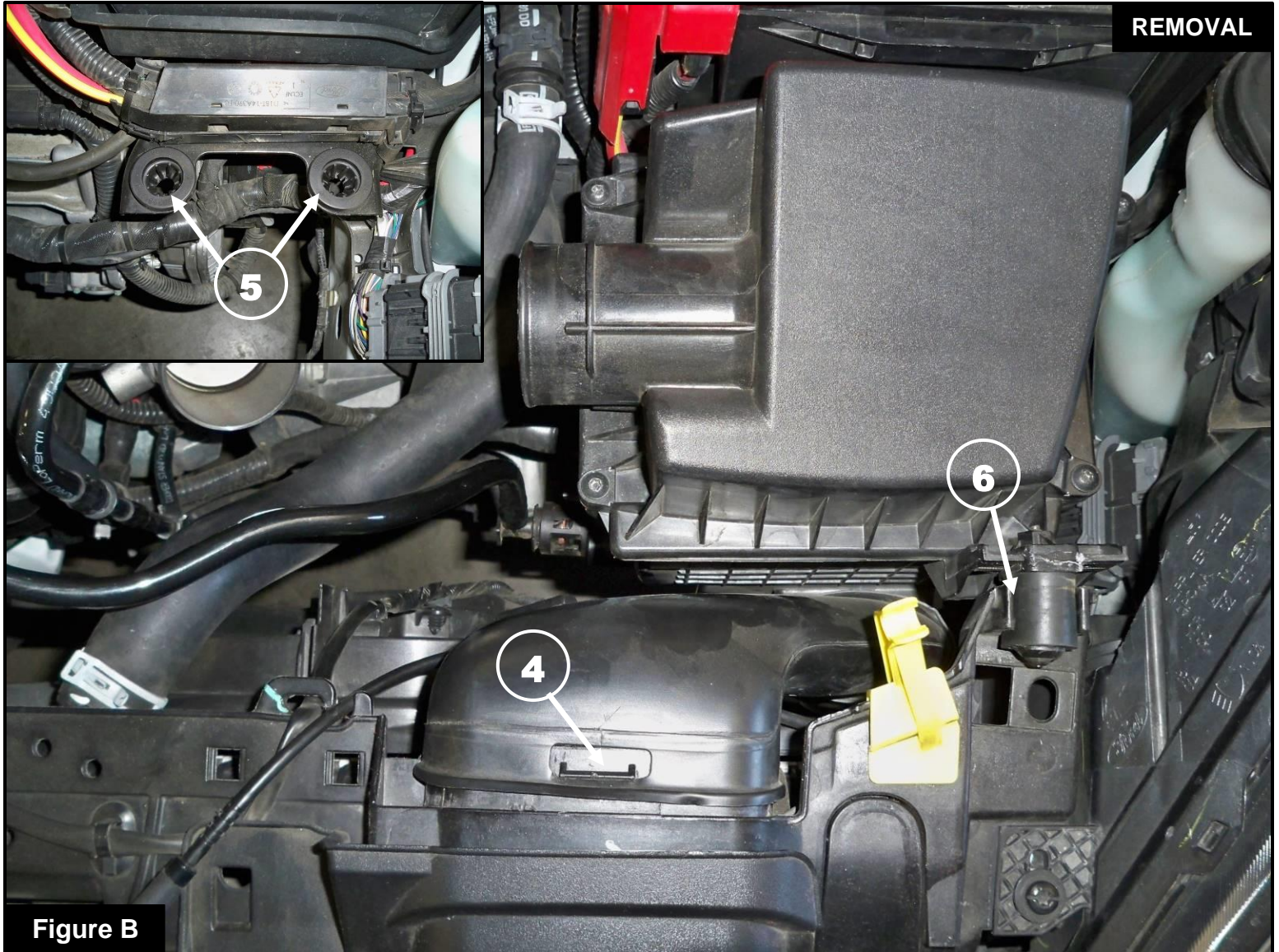

Refer to Figure B for Step 5

Step 5: Using a small flat blade screwdriver, release the tab (4) at the scoop section and remove the airbox by pulling up to release from its mounting grommets (5) and mounting pin bracket (6). Make sure the mounting grommets are still in the mounting bracket tabs. If they pulled out and are stuck in the lower half of the airbox, remove them from the airbox and insert them back on the mounting bracket tabs.

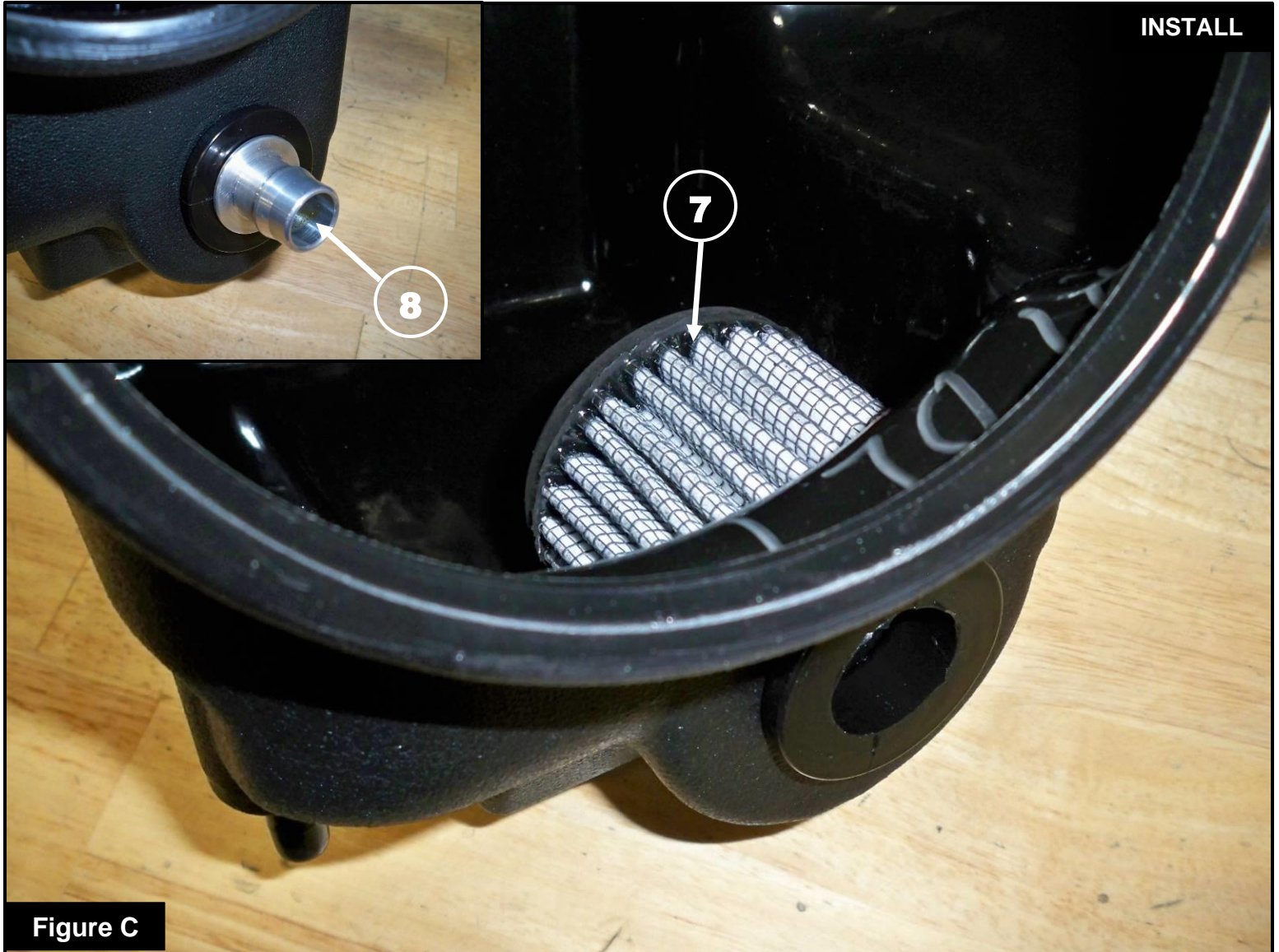

Figure C

Refer to Figure C for Steps 6-7

Step 6: Install the breather filter (7) from inside the Takeda housing through the small opening as shown.

Step 7: Push the supplied aluminum crankcase vent fitting (8) into the breather filter as shown.

**Figure D****Refer to Figure D for Steps 8-9**

Step 8: Remove the rubber isolator (9) from the airbox mounting pin and install it on the Takeda housing mounting pin as shown.

Step 9: Install the Takeda plug (10) on the side of the Takeda housing as shown.

NOTE: This plug is accessible to be removed and installed at any time to increase airflow and engine sound if desired.

Figure E

Refer to Figure E for Steps 10-13

Step 10: Install the Takeda housing into the vehicle by pushing down the housing pins into the mounting grommets, snapping in the rubber isolator (11) to the mounting pin bracket and inserting the scoop section until the release tab (12) snaps on. Make sure the pins are completely through the mounting grommets and the release tab is holding the housing.

Step 11: Slide the Takeda filter and clamp into the Takeda housing and push it in until it locks into place. Do not tighten the clamp.

Step 12: Install the coupling fitting (13) into the vacuum hose until fully seated.

Step 13: Connect the crankcase vent line (14) to the aluminum crankcase vent fitting.

**Figure F****Refer to Figure F for Step 14**

Step 14: Place the supplied #32 clamp (15) on the Takeda silicone intake tube as shown. Do not tighten the clamp.



Refer to Figure G for Steps 15-18

Step 15: Install the Takeda silicone intake tube into the vehicle. Slide it onto the throttle body first and then into the air filter.

Step 16: Align the Takeda silicone intake tube and clamps correctly, then using an 8mm nut driver tighten the clamps.

Step 17: Connect the vacuum hose with the coupling fitting (16) into the silicone intake tube.

Step 18: Check all the components are tight and secure. Your installation is now complete. Thank you for choosing aFe POWER!

NOTE: Check all bolts, clamps, and connectors after 100-200 miles.



Page left blank intentionally



advanced FLOW engineering, inc.

252 Granite Street Corona, CA 92879
TEL: 951.493.7100 • TECH: 951.493.7134
E-Mail: Tech@aFepower.com