

advanced FLOW engineering

Instruction Manual P/N: 56-70052D / 56-70052R

Cold Air Intake System

Make: Acura

Model: TLX

Year: 2021-2022

Engine: L4-2.0L(t)



- Please read the entire instruction manual before proceeding.
- Ensure all components listed are present.
- For technical support please call 951-493-7185.
- Ensure you have all necessary tools before proceeding.
- Do not attempt to work on your vehicle when the engine is hot.
- Retain factory parts for future use.

Label	Qty.	Description	Part Number
A	1	Air Filter (Pro 5R)	24-91103
A	1	Air Filter (Pro DRY S)	21-91103
B	1	Tube	05-5670052B1
C	1	Housing	05-5670052B2
D	1	Coupling, Silicone Bellow: (2.75"x3")ID x 3.5"L	05-01455
E	2	Clamp, 044 (2-5/16" - 3-1/4")	03-50019
F	1	Plug, Air Box	05-01527
G	2	Screw, M5 x 16mm	03-50322
H	2	Screw, M4 x 8mm	03-50491
J	1	Extension Harness: MAF Sensor	05-70045
K	2	Cable Tie	05-60167
M	1	Mini Clamp, 004 (1/8" – 5/16")	03-50097

Installation will require the following tools:

Trim removal tool, Ratchet wrench, Ratchet Extension, T20 Torx driver, Phillips screwdriver, 10mm and 8mm sockets.

Warranty Information available at <https://afepower.com/contact#warranty>

Emissions Disclaimer: This product is not currently CARB exempt and is not available for purchase in California or for use on any vehicle registered with the California Department of Motor Vehicles.

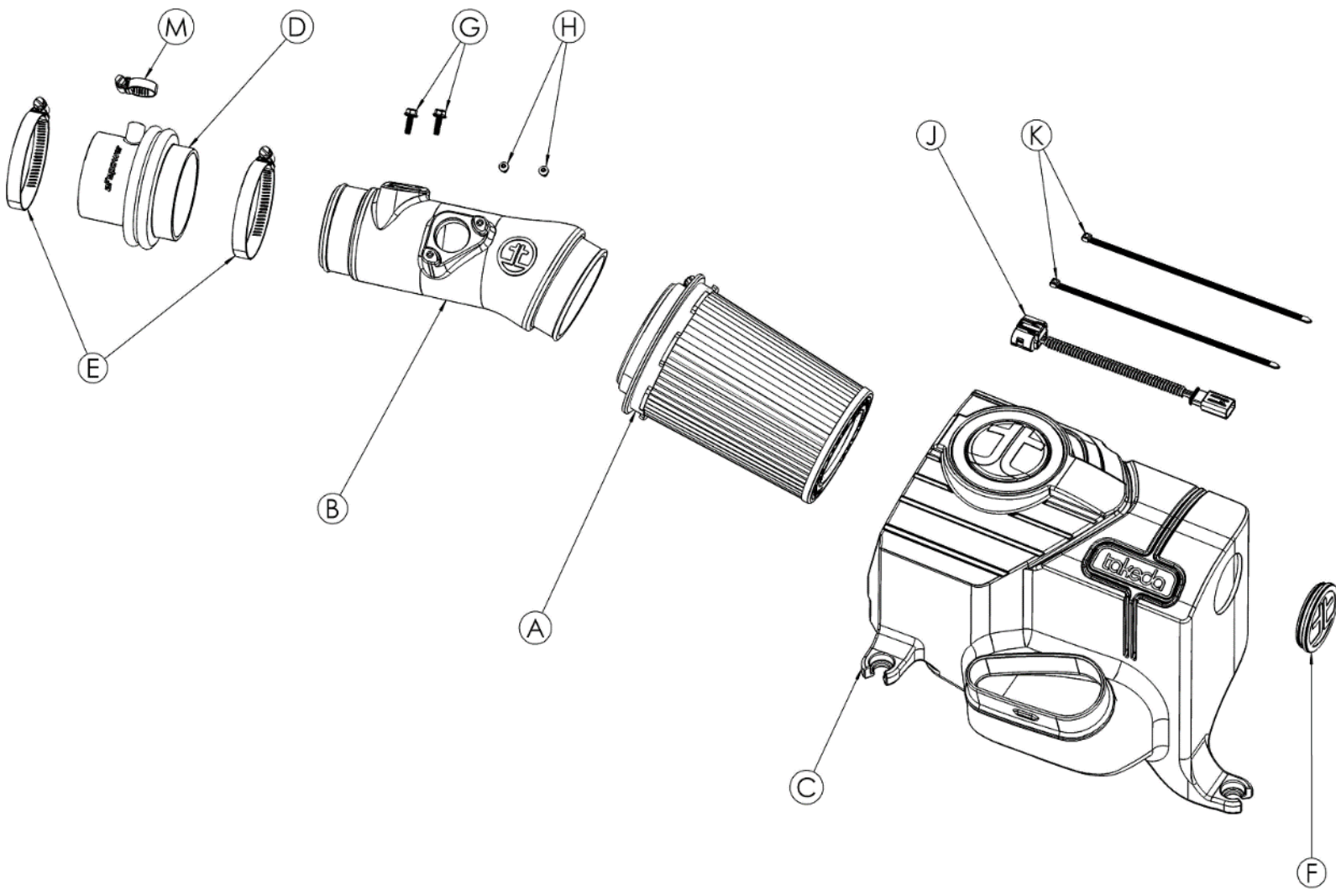



Figure A

Refer to Figure A for Step 1

Step 1: Unplug the MAF (Mass Air Flow) sensor ①.



Figure B

Refer to Figure B for Steps 2-4

Step 2: Using a 10mm nut driver, remove the two screws holding the fitting (2) and pull it from the tube.

Step 3: Loosen the clamp (3) connecting the coupler to the turbo inlet.

Step 4: The hard vacuum line (4) is secured with a single use clamp. Remove the line by firmly pulling it out of the coupling.



Figure C

Refer to Figure C for Step 5

Step 5: Using a 10mm socket, remove the three bolts (5) securing the airbox.



Figure D

Refer to Figure D for Steps 6-8

Step 6: Using a trim removal tool, remove the pop rivet (6) securing the air inlet.

Step 7: Pull the inlet back to remove the clip (7) from the cowl.

Step 8: The factory intake can now be removed in one piece.

**Figure E****Refer to Figure E for Steps 9-10**

Step 9: Using a T20 torx driver, transfer the MAF sensor from the factory intake to the Takeda tube using the provided screws.

Step 10: Attach the bellow coupler and two clamps onto the tube assembly as shown but do not tighten them completely at this time.

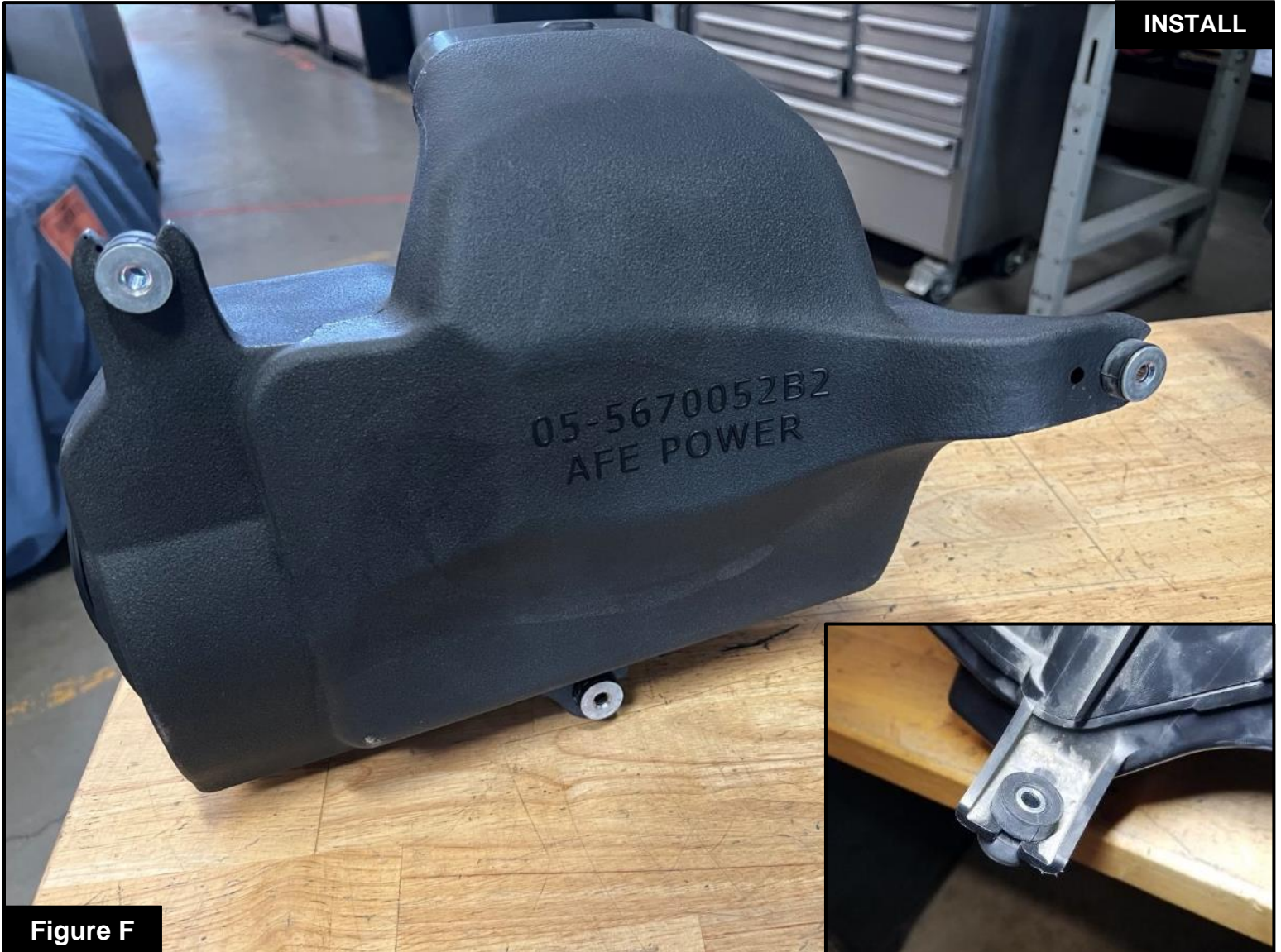

Figure F

Refer to Figure F for Step 11

Step 11: Transfer the three gromets to the new Takeda housing.

**Figure G****Refer to Figure G for Step 12**

Step 12: Install the air filter by firmly pushing it into the housing. The polyurethane tabs will lock it in place when the filter is fully installed. Place the provided clamp on the filter but do not tighten it at this time.

**Figure H**

Refer to Figure H for Step 13

Step 13: This kit includes an optional plug to close off the auxiliary air inlet. Install the plug if you wish to only capture cold air from the factory inlet.

- Without the plug installed, the Takeda intake will capture the maximum air available. More airflow offers more power, yet some of this air is picked up from inside the engine compartment and could be warmer, which will affect the performance of the vehicle.
- The plug installed on the housing will block off any hot engine air entering the housing to make sure the coolest air available is directed into the engine. Intake noise will also be reduced using the plug.

**Figure I****Refer to Figure I for Step 14**

Step 14: Install the Takeda housing into the engine bay and secure it using the three (3) screws removed in **Step 5**. Do not tighten these screws completely at this time.



Refer to Figure J for Steps 15-16

Step 15: Remove the inlet piece from the factory inlet and install it on the Takeda housing.

Step 16: Pull the inlet piece forward to snap it into the cowel, then reinstall the factory push clip removed in **Step 6**.

**Figure K**

Refer to Figure K for Step 17-20

Step 17: Install the Takeda tube and coupling assembly by first installing the coupling on the turbo inlet, followed by inserting the tube into the filter. To ensure the Takeda tube is clocked correctly, feel for any gaps between the tube and filter.

Step 18: Install the vacuum line removed in **Step 4** into the bellow coupler. Secure it using the provided mini clamp.

Step 19: Install the plastic fitting removed in **Step 2** and secure it using the provided screws.

Step 20: Tighten all clamps and screws.

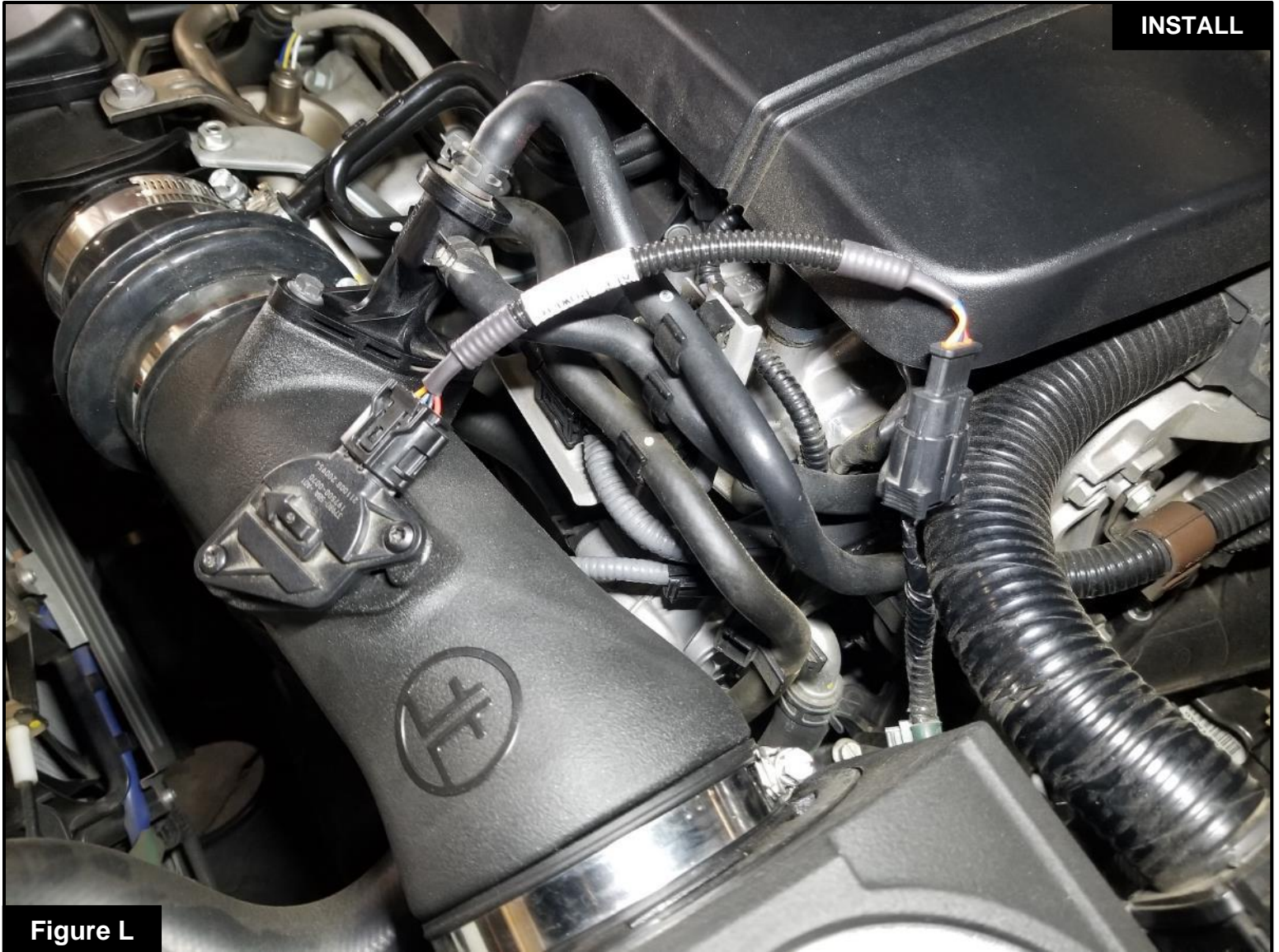
**Figure L****Refer to Figure L for Steps 21**

Step 21: Connect the provided MAF extension harness to the MAF sensor and factory harness. Use the supplied cable ties to secure the harness.



Refer to Figure M for Step 22

Step 22: Make sure that all clamps and connections are secured. Your installation is now complete. Thank you for choosing Takeda USA!

NOTE: Check to ensure that all screws, clamps, and connectors are secured after 100-200 miles.



THIS PAGE LEFT BLANK INTENTIONALLY



THIS PAGE LEFT BLANK INTENTIONALLY



THIS PAGE LEFT BLANK INTENTIONALLY



advanced FLOW engineering, inc.

Corona, CA 92879

<https://afepower.com/contact>