

advanced FLOW engineering

Cold Air Intake System

Instruction Manual P/N: 56-70053D / 56-70053R

Make: Honda
Make: Honda
Make: Acura

Model: Civic
Model: Civic Si
Model: Integra

Year: 2022-2023
Year: 2022-2023
Year: 2023-2023

Engine: L4-1.5L(t)
Engine: L4-1.5L(t)
Engine: L4-1.5L(t)



- Please read the entire instruction manual before proceeding.
- Ensure all components listed are present.
- If you are missing any of the components, call customer support at 951-493-7185.
- Ensure you have all necessary tools before proceeding.
- Do not attempt to work on your vehicle when the engine is hot.
- Retain factory parts for future use.

Label	Qty.	Description	Part Number
A	1	Air Filter (Pro 5R) For 56-70053R	24-91103
A	1	Air Filter (Pro DRY S) For 56-70053D	21-91103
B	1	Tube	05-5670053B1
C	1	Housing	05-5670053B2
D	1	Coupling, Silicone Reducer: (2-5/8" x 3") ID x 3'L	05-01730
E	1	Clamp, #048 (2-9/16" - 3-1/2 ")	03-50007
F	1	Clamp, #044 (2-5/16" - 3-1/4")	03-50019
G	2	Screw, M4 x 8mm	03-50491
H	1	Extension Harness: MAF sensor	05-70045
J	1	Plug, Air Box	05-01527
K	2	Cable tie	05-60167

Installation will require the following tools:

Socket set, extension, ratchet, T-20 Torx screwdriver, Phillips screwdriver

Warranty Information available at: <https://afepower.com/contact#warranty>

Emissions Disclaimer: This product is not currently CARB exempt and is not available for purchase in California or for use on any vehicle registered with the California Department of Motor Vehicles.

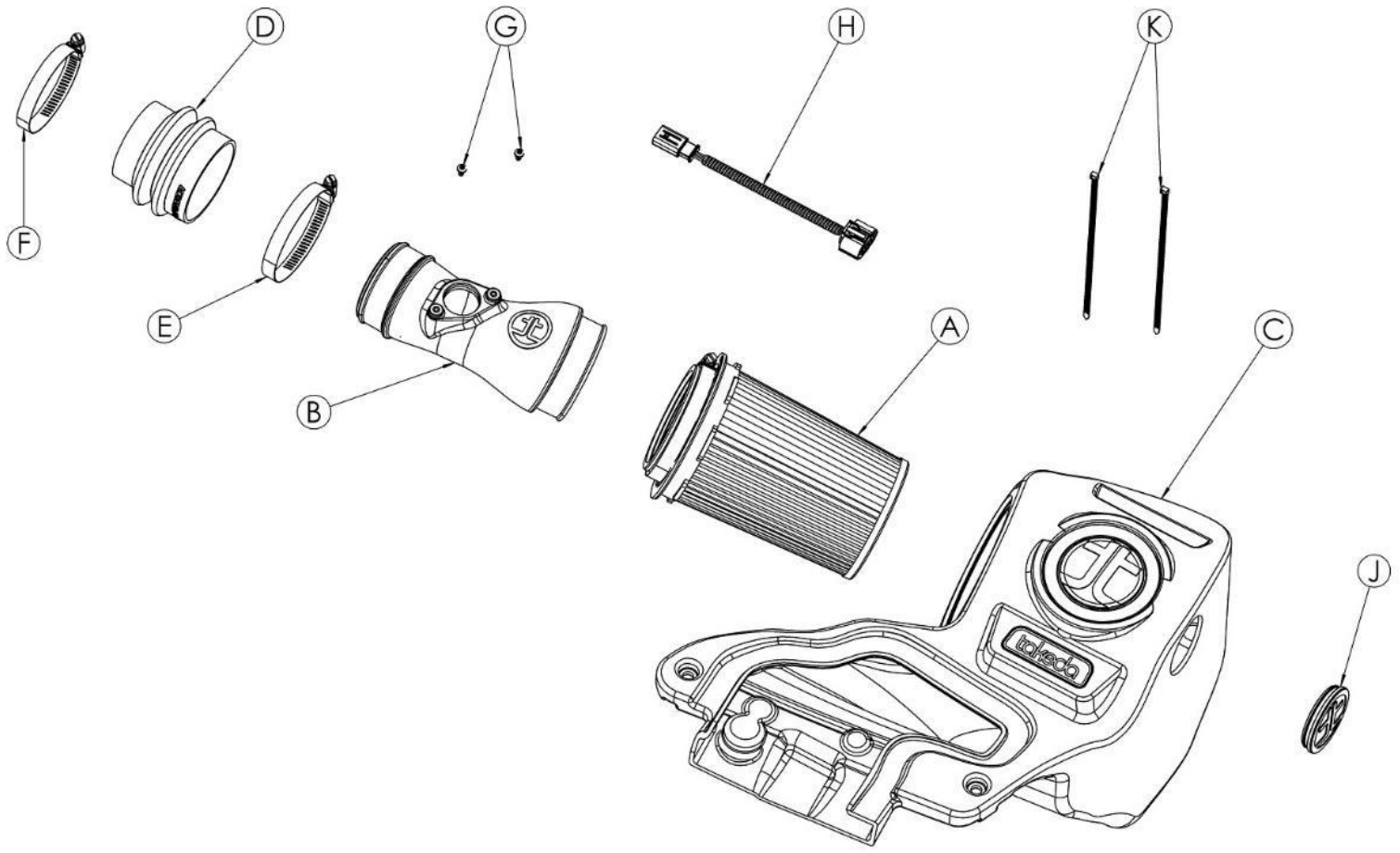



Figure A

Refer to Figure A for Step 1

Step 1: Disconnect the Mass Air Flow sensor (MAF) harness.

**Figure B****Refer to Figure B for Steps 2-4**

Step 2: Remove the plastic retaining clip securing the factory scoop.

Step 3: Remove the two (2) 10mm screws securing the factory scoop and set them aside for later use.

Step 4: Remove the 10mm screw securing the scoop to the bracket next to the factory air inlet.



Figure C

Refer to Figure C for Step 5

Step 5: Remove the 10mm screw securing the factory housing to the frame.



Figure D

Refer to Figure D for Steps 6-7

Step 6: Loosen the clamp securing the intake tube to the turbo inlet tube.

Step 7: Then pull up on the factory housing and tube to remove as one piece out of the vehicle.



REMOVAL

Figure E

Refer to Figure E for Step 8

Step 8: Remove the two (2) 10mm screws holding the mounting bracket.

**Figure F****Refer to Figure F for Steps 9-10**

Step 9: Transfer the Mass Air Flow sensor from the factory housing to the Takeda tube and secure it with the supplied M4 screws.

Step 10: Place the supplied coupling onto the Takeda tube. Place the clamps on the coupling and tighten only the clamp on the tube side at this time.

**Figure G****Refer to Figure G for Step 11**

Step 11: Install the air filter into the housing by firmly pushing it into the housing until the filter tabs lock it into place. Install the clamp on the filter, but do not tighten at this time.

Figure H

Refer to Figure H for Step 12

Step 12: This kit includes an optional plug to close off the auxiliary air inlet. Install the plug if you wish to close it off to only capture cold air from the factory inlet.

- Without the plug installed, the Takeda intake will capture the maximum air available. More airflow offers more power, yet some of this air is picked up from the inside the engine compartment and could be warmer air, which will affect the performance of the vehicle.
- The plug installed on the housing will block off any hot engine air entering the housing to make sure the coolest air available is directed into the engine. Intake noise will also be reduced is using the plug.



Figure I

Refer to Figure I for Step 13

Step 13: Transfer the grommet from the factory housing onto the hole at the bottom of the Takeda housing.



Figure J

Refer to Figure J for Steps 14-15

Step 14: Install the assembled Takeda housing into the engine bay.

Step 15: Secure it by tightening the two (2) screws removed at **step 3**.

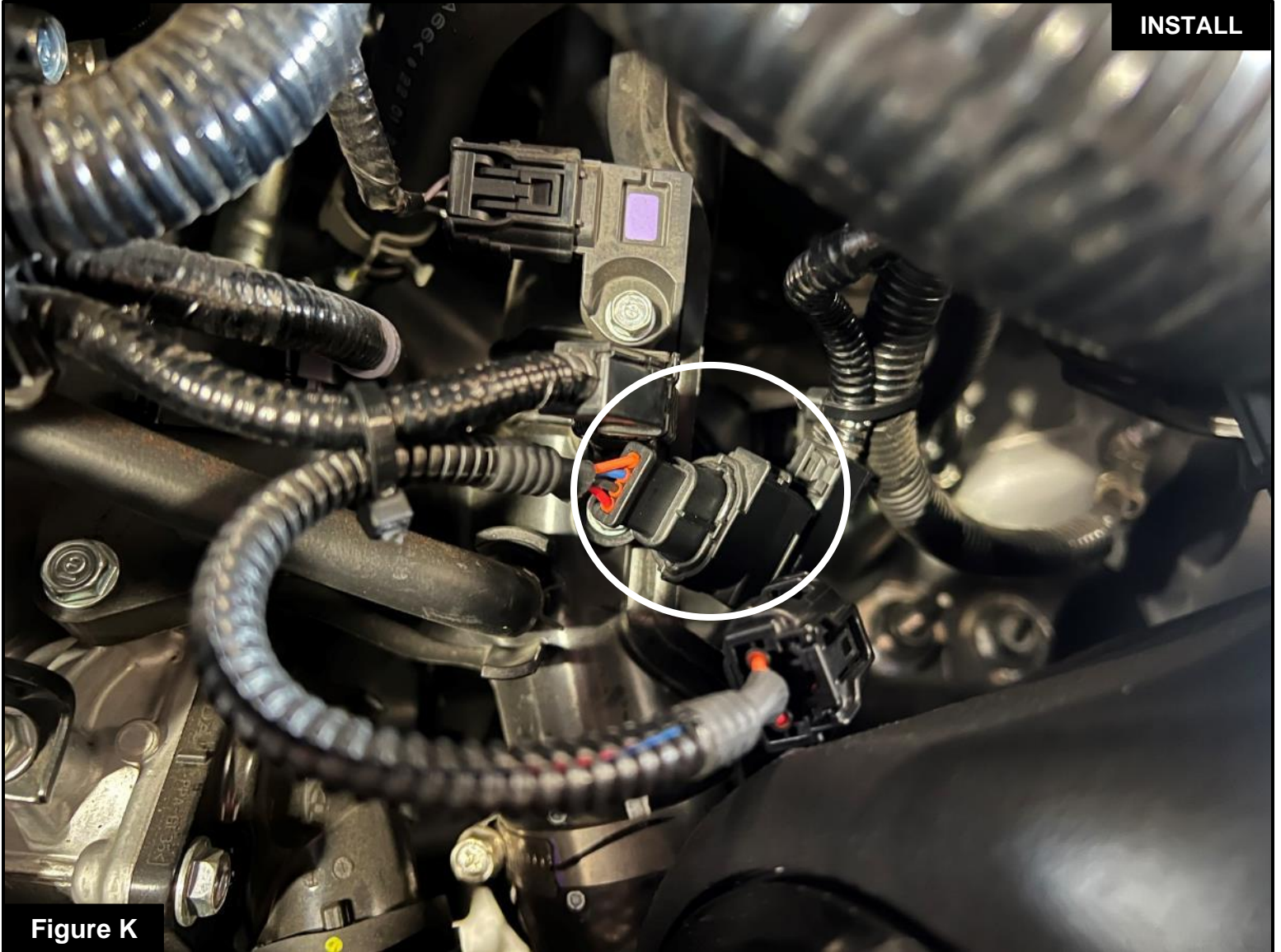

Figure K

Refer to Figure K for Step 16

Step 16: Connect the supplied extension harness to the factory Mass Air Flow sensor harness.

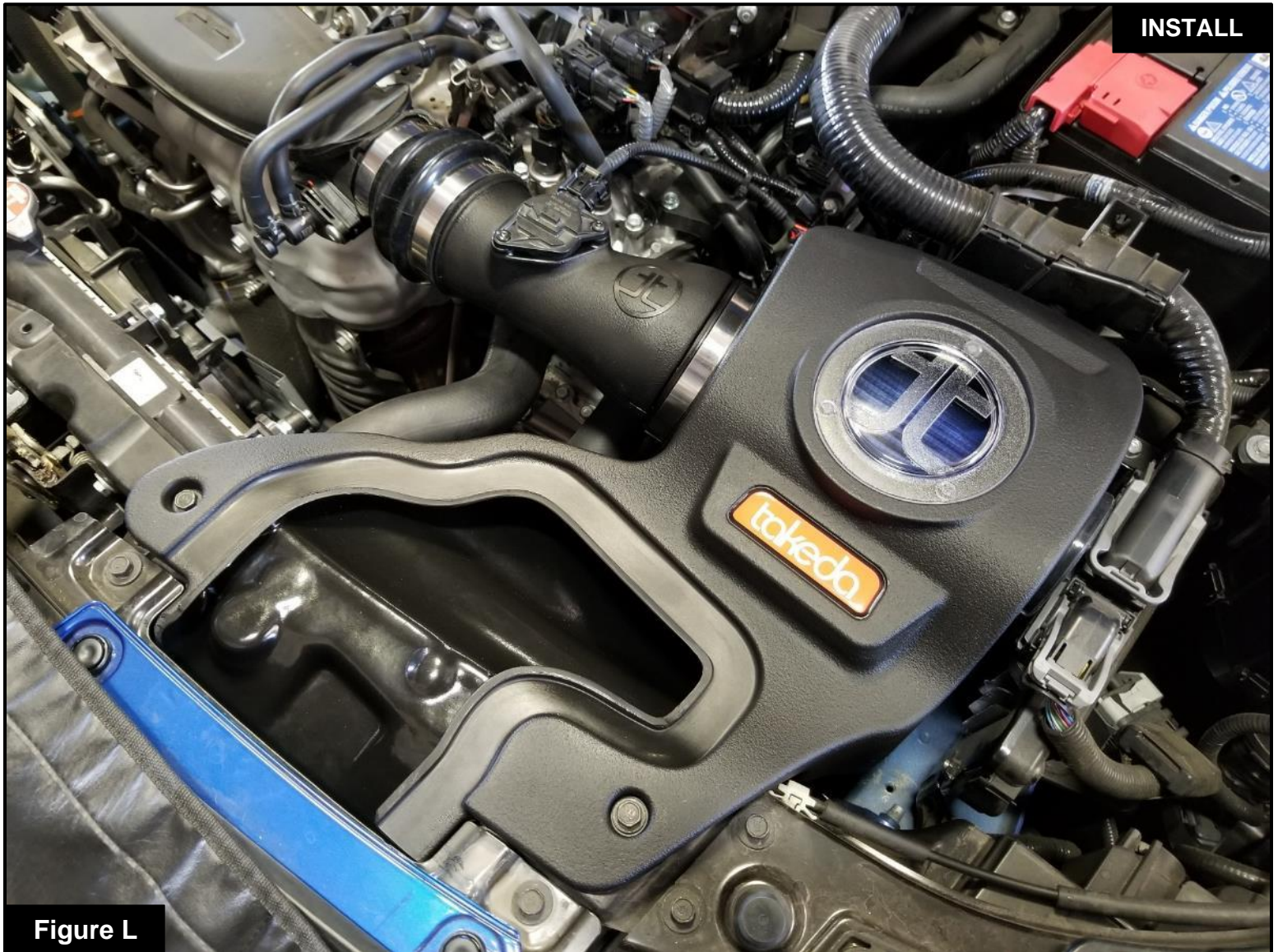

Figure L

Refer to Figure L for Steps 17-19

Step 17: Slip the Takeda intake tube into the air filter and over the turbo inlet tube. Align the tube, filter and coupling, then tighten all clamps.

Step 18: Connect the supplied Mass Air Flow sensor extension harness into the Mass Air Flow sensor. Use the supplied cable ties to secure the harness.

Step 19: Make sure that all clamps and connections are secured. Your installation is now complete. Thank you for choosing Takeda USA!

NOTE: Check to ensure that all screws, clamps, and connectors are secure after 100-200 miles.



advanced FLOW engineering, inc.

Corona, CA 92879

<https://afepower.com/contact>