

advanced FLOW engineering

Cold Air Intake System

Instruction Manual P/N: 56-70060D / 56-70060R

Make: **Kia**

Model: **Stinger**

Year: **2022-2023**

Engine: **L4-2.5L(t)**



- Please read the entire instruction manual before proceeding.
- Ensure all components listed are present.
- For technical support please call 951-493-7185.
- Ensure you have all necessary tools before proceeding.
- Do not attempt to work on your vehicle when the engine is hot.
- Retain factory parts for future use.

Label	Qty.	Description	Part Number
A	1	Air Filter (Pro 5R)	24-90114
A	1	Air Filter (Pro DRY S)	21-90114
B	1	Tube	05-5670060B1
C	1	Housing	05-5670060B2
D	1	Plug, Air Box	05-01527
E	1	Coupling, Bellows: 3-3/32"ID x 3"L w/ IB	05-01525
F	2	Clamp, 048 (2-9/16" - 3-1/2 ")	03-50007
G	1	Fitting, 11mm Barbed (Four-barb) to 1/8" NPT	03-50615
H	1	Fitting, 12mm Barbed (Five-Barb) to 1/8" NPT	03-50824
J	1	Insert, Vent Tube	03-50833

Installation will require the following tools:

Pliers, Channel lock pliers, 10mm open end wrench, flat head screwdriver, 8mm nut driver, Socket wrench and extensions, 10mm socket, 16mm socket

Warranty Information available at <https://afepower.com/contact#warranty>

Emissions Disclaimer: This product is not currently CARB exempt and is not available for purchase in California or for use on any vehicle registered with the California Department of Motor Vehicles.

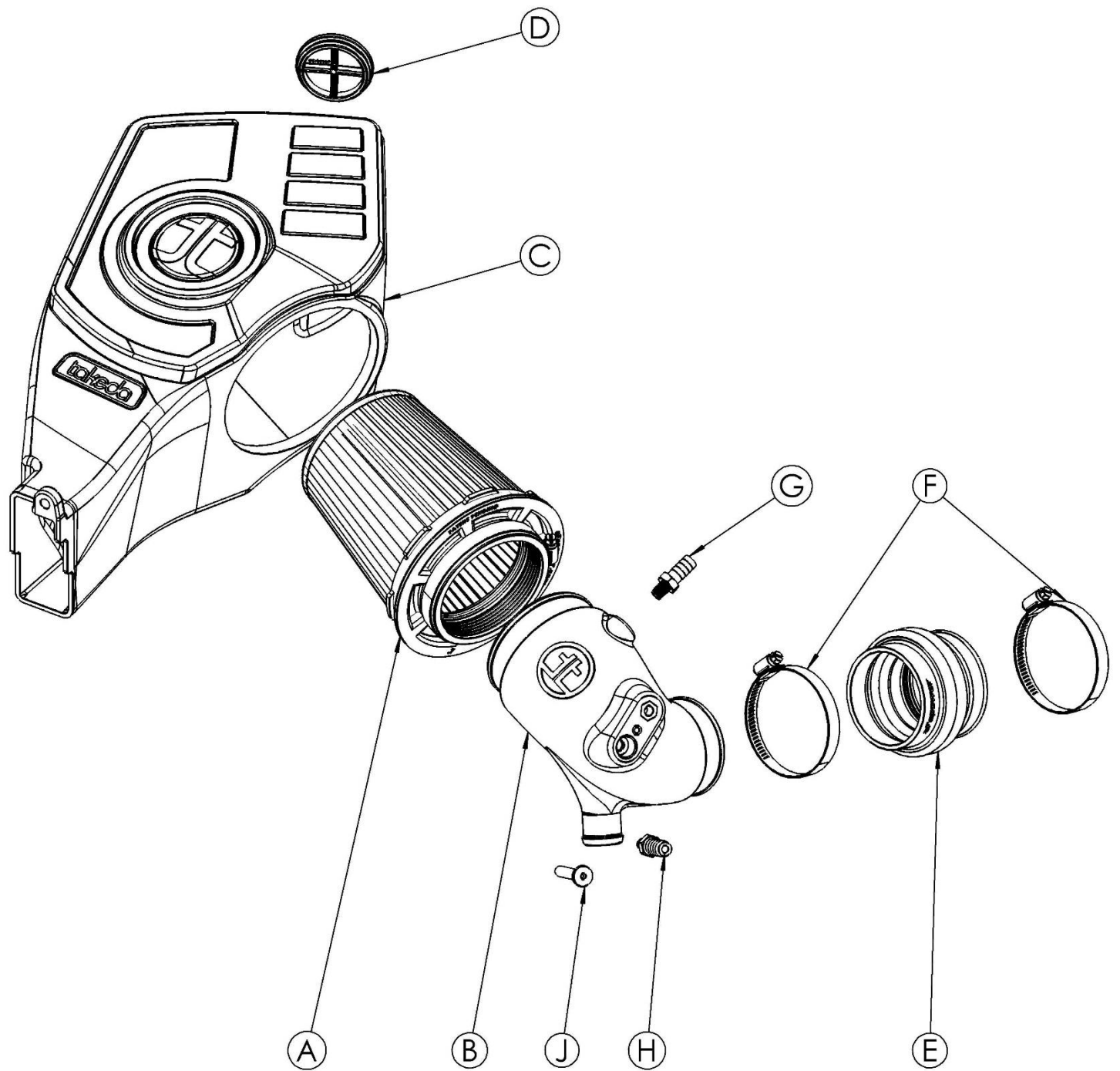



Figure A

Refer to Figure A for Step 1

Step 1: Undo the two 12mm bolts ① and remove the factory brace.

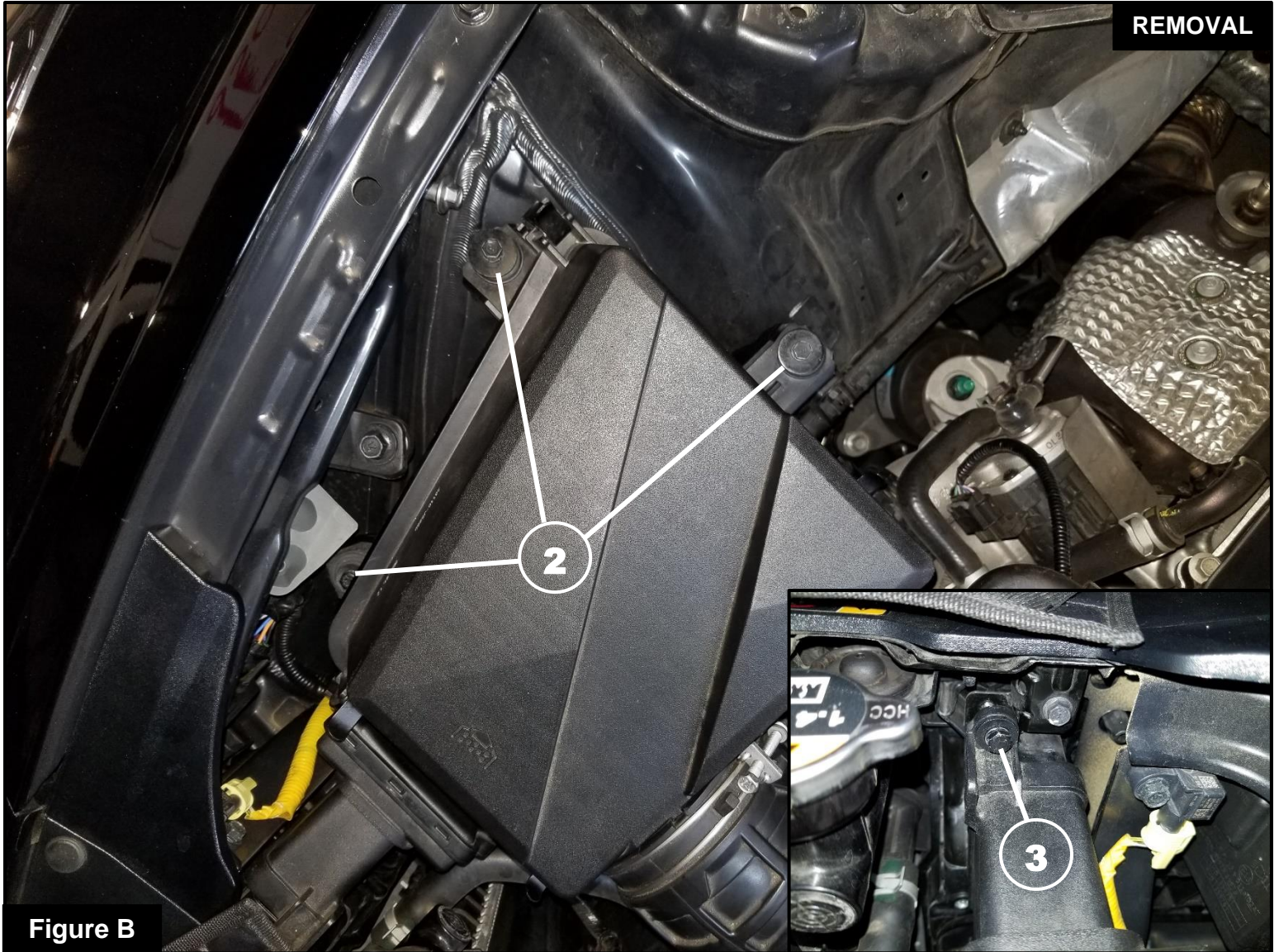

Figure B

Refer to Figure B for Step 2

Step 2: Using a 10mm socket, remove the three screws ② securing the airbox as well as the two screws attaching the top and bottom of the inlet ③.

**Figure C****Refer to Figure C for Step 3**

Step 3: Locate the clip that secures the OE intake tube to the turbo inlet. Press both ends of the clip ④ outward and lock them in place.

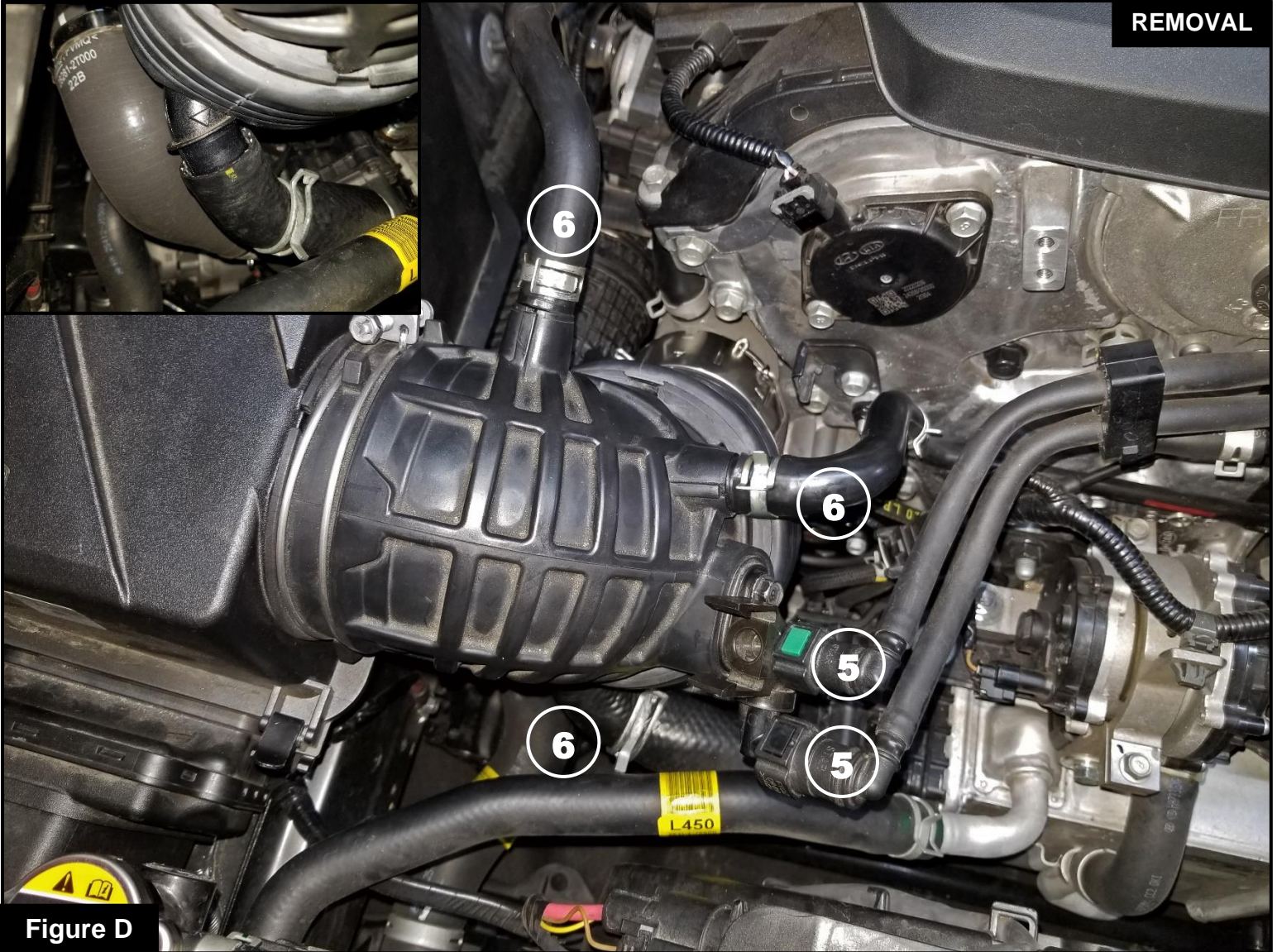
**Figure D****Refer to Figure D for Steps 4-6**

Step 4: Squeeze both sides of the vacuum line clips (5) to release them. Then remove them from the vacuum port.

Step 5: Pull the three spring clamps (6) back on their respective hoses and remove the hoses from the tube.

Step 6: You can now remove the airbox, tube, and inlet as one piece.



Figure E

Refer to Figure F for Step 7

Step 7: Transfer two of the gromets (7) from the OEM airbox to the new Takeda housing.

**Figure F**

Refer to Figure F for Step 8

Step 8: This kit includes an optional plug to close off the auxiliary air inlet. Install the plug if you wish to only capture cold air from the factory inlet.

- Without the plug installed, the Takeda intake will capture the maximum air available. More airflow offers more power, yet some of this air is picked up from inside the engine compartment and could be warmer, which will affect the performance of the vehicle.
- The plug installed on the housing will block off any hot engine air entering the housing to make sure the coolest air available is directed into the engine. Intake noise will also be reduced using the plug.



Figure G

Refer to Figure G for Step 9

Step 9: Install the included aluminum vent tube into the Takeda tube as shown.

Figure H
Refer to Figure H for Step 10-13

Step 10: Using an 8mm nut driver, remove the screw holding the vacuum port (8) to the OEM intake tube and transfer it to the Takeda tube. Secure it with the same screw.

Step 11: Thread the five-barb fitting (9) into the threads adjacent to the vacuum port.

Step 12: Thread the supplied four-barb fitting (10) into the tube as shown.

Step 13: Tighten both fittings using a 16mm wrench or deep socket. **DO NOT OVER TIGHTEN. SPACE BETWEEN THE 16MM HEX AND TUBE IS NORMAL.**



Figure I

Refer to Figure I for Step 14

Step 14: Install the supplied coupling to the turbo inlet and secure it using one of the provided clamps. Ensure the interior lip of the coupling is seated properly before tightening the clamp.

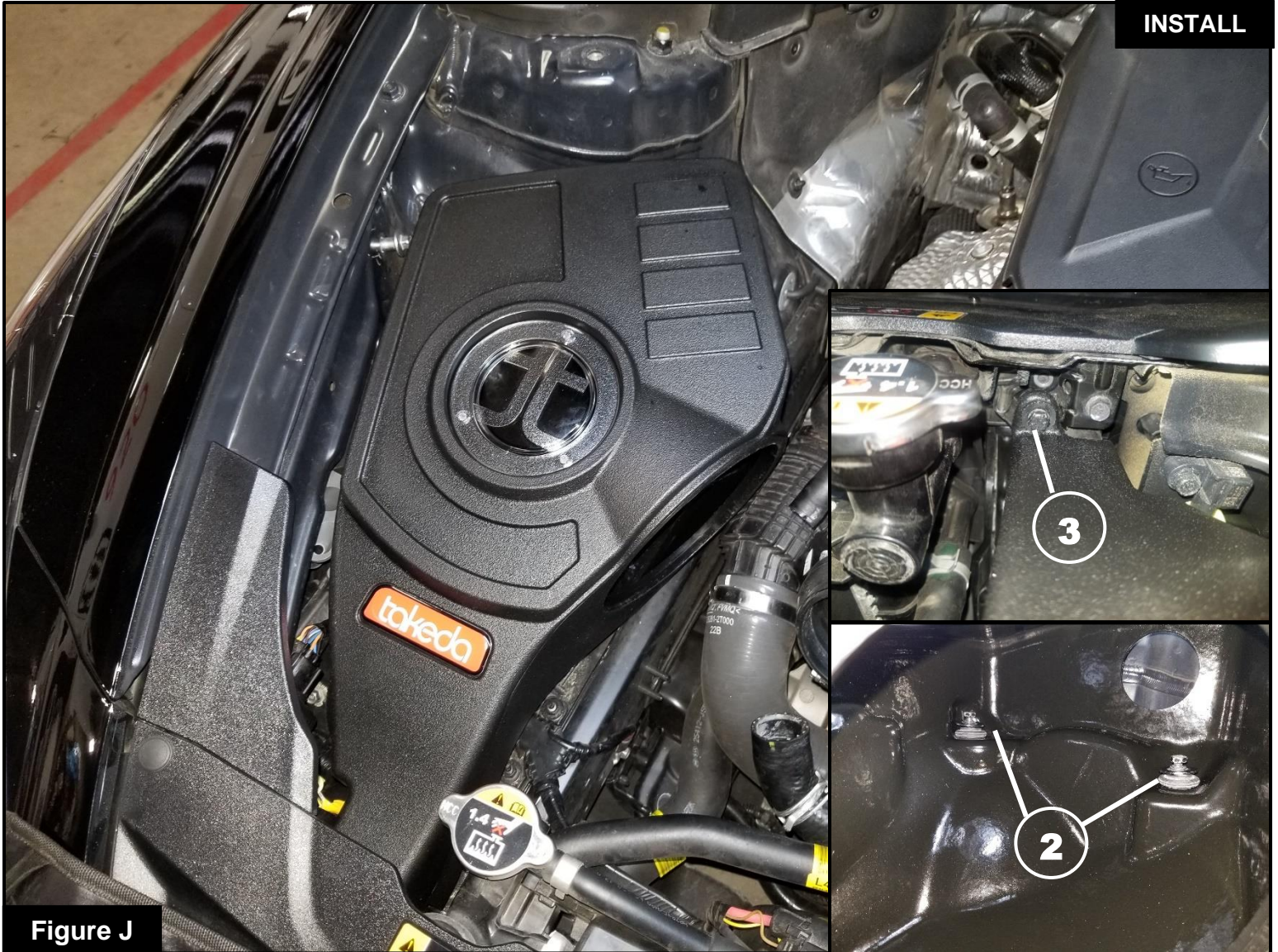

Figure J

Refer to Figure J for Step 15

Step 15: Install the Takeda housing into the engine bay and secure it using screws (2) and (3) removed in **Step 2**. Ensure that these screws correspond to the location they were removed from.



Refer to Figure K for Steps 16

Step 16: Install the air filter into the housing by firmly pushing it into the housing until the filter tabs lock it into place.



Figure L

Refer to Figure L for Step 17

Step 17: Install the Takeda tube by first inserting it into the coupling on the turbo inlet, followed by inserting the tube into the filter. To ensure the Takeda tube is clocked correctly, feel for any gaps between the tube and filter. Tighten all clamps.

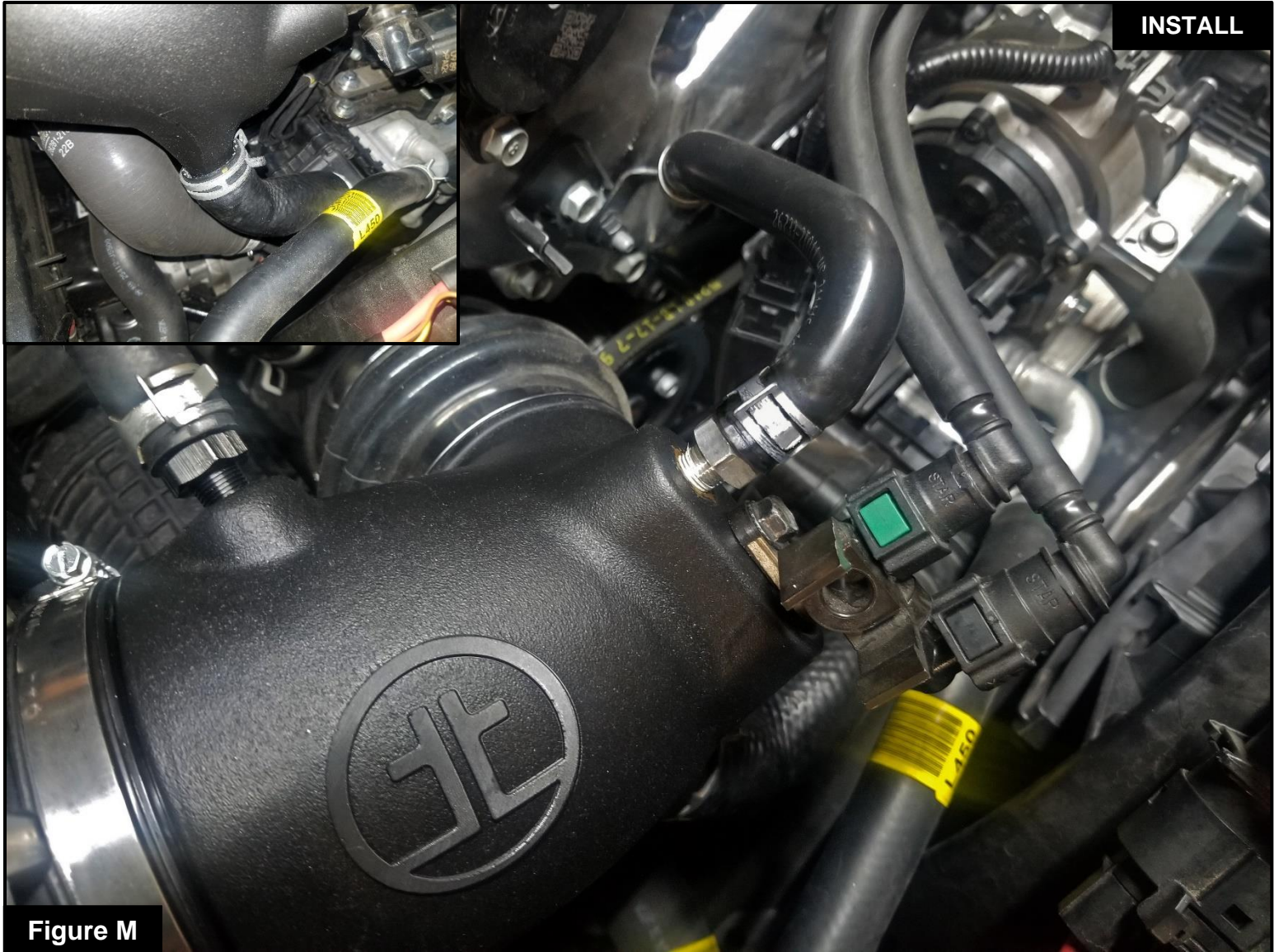

Refer to Figure M for Steps 18-19

Step 18: Clip the vacuum lines back onto the port.

Step 19: Attach the three hoses removed in **Step 5** to the tube as shown and secure them with the spring clamps.



Figure N

Refer to Figure N for Steps 20-21

Step 20: Reattach the brace removed in **Step 1**.

Step 21: Make sure that all clamps and connections are secured. Your installation is now complete. Thank you for choosing Takeda USA!

NOTE: Check to ensure that all screws, clamps, and connectors are secured after 100-200 miles.



THIS PAGE LEFT BLANK INTENTIONALLY



THIS PAGE LEFT BLANK INTENTIONALLY



advanced FLOW engineering, inc.

Corona, CA 92879

<https://afepower.com/contact>