

# advanced FLOW engineering

Cold Air Intake System

## **Instruction Manual** P/N: 57-10010R / 57-10010D

Make: <b>FORD</b>	Model: <b>F-150 RAPTOR</b>	Year: <b>2017-2020</b>	Engine: <b>V6-3.5L(tt)</b>
Make: <b>FORD</b>	Model: <b>F-150</b>	Year: <b>2017-2020</b>	Engine: <b>V6-3.5L(tt)</b>
Make: <b>FORD</b>	Model: <b>EXPEDITION</b>	Year: <b>2018-2021</b>	Engine: <b>V6-3.5L(tt)</b>
Make: <b>LINCOLN</b>	Model: <b>NAVIGATOR</b>	Year: <b>2018-2021</b>	Engine: <b>V6-3.5L(tt)</b>



- Please read the entire instruction manual before proceeding.
- Ensure all components listed are present.
- If you are missing any of the components, call customer support at 951-493-7185.
- Ensure you have all necessary tools before proceeding.
- Do not attempt to work on your vehicle when the engine is hot.
- Retain factory parts for future use.

Label	Qty.	Description	Part Number
A	1	Air Filter (Pro 5R) For 57-10010R	24-91149
A	1	Air Filter (Pro DRY S) For 57-10010D	21-91149
B	1	Tube, Carbon Fiber	05-5710010C1
C	1	Housing, Plastic	05-5710010B2
D	1	Coupling, Silicone Reducer: (3-1/2" x 3")ID x 2-1/2"L	05-01580
E	1	Coupling, Silicone Bellow: 4"ID x 2-1/2"L	05-01399
F	1	Clamp, 044 (2-5/16" - 3-1/4")	03-50019
G	1	Clamp, 052 (2-13/16" - 3-3/4 ")	03-50008
H	2	Clamp, 064 (2-1/2"- 4-1/2 ")	03-50006
J	1	Insert, Vent tube	05-01405
K	1	Seal, Trim: 13/32" double bulb (41-1/2" Length)	05-01534
M		Retainer Clip, Push-In Style	03-50773

**Installation will require the following tools:**

7mm, 8mm, 11mm and 13mm Nut Drivers or Ratchet and Sockets, Flat Head Screwdriver

Warranty Information available at: <https://afepower.com/contact#warranty>

**Product covered by one or more of the following patents:** 11125150, 11603792, 10648404

**Emissions Disclaimer:** This product is not currently CARB exempt and is not available for purchase in California or for use on any vehicle registered with the California Department of Motor Vehicles.

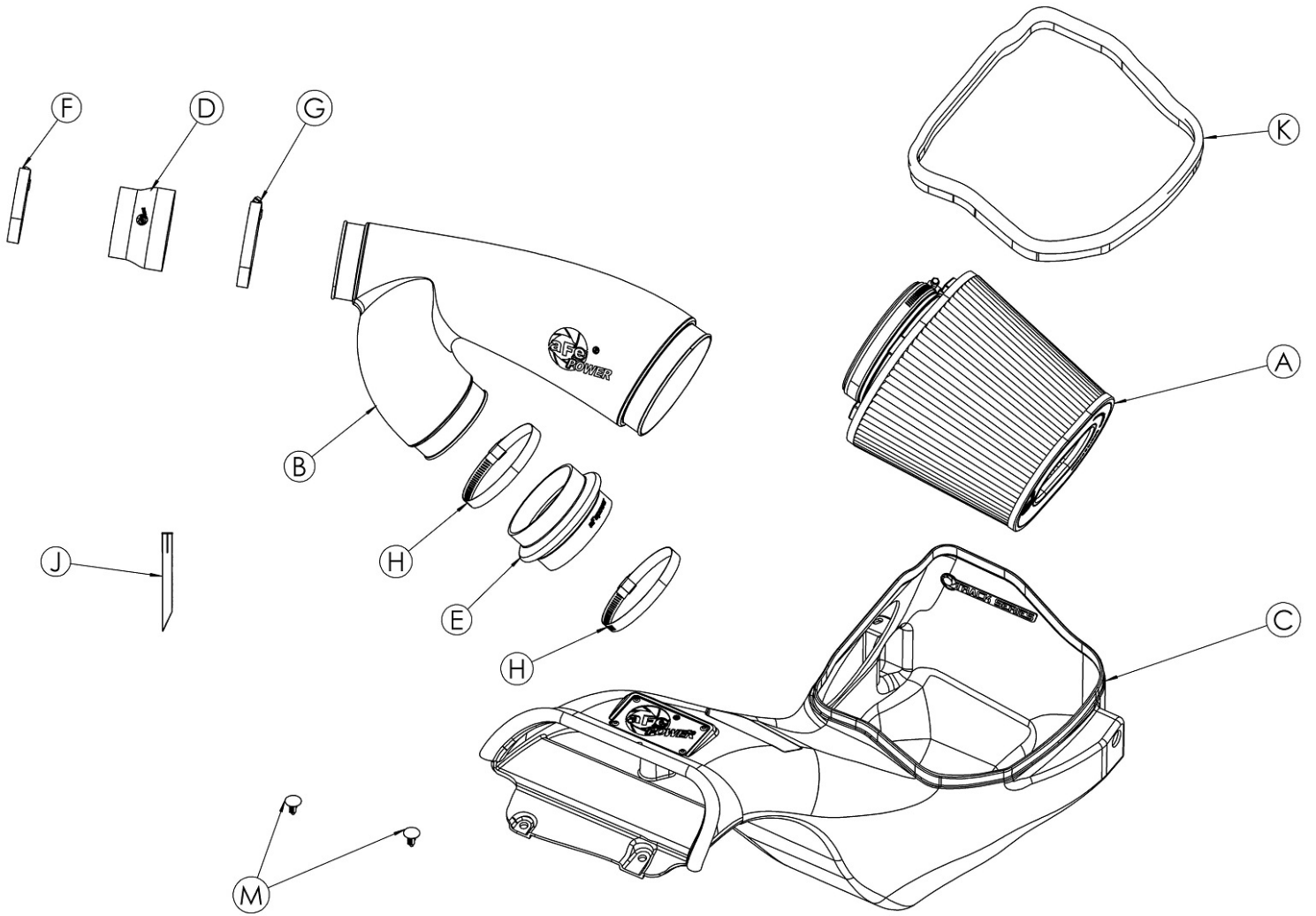



**Refer to Figure A for Step 1**

Step 1: Unplug the temperature sensor harness and unclip it from the intake tube.

**Figure B****Refer to Figure B for Steps 2-5**

Step 2: Loosen the two clamps connecting the intake tube to the turbo inlet tubes.

Step 3: Unclip the coolant line from the intake tube.

Step 4: Unclip the top of the factory air box and remove the intake tube, air filter and top of the air box from the vehicle.

Step 5: Remove the two plastic rivets securing the front scoop of the housing.



**Figure C**

**Refer to Figure C for Steps 6-8**

Step 6: Remove the wastegate acuator from the housing (it will be reinstalled onto the aFe POWER housing).

Step 7: Unclip the wire from the back of the air box.

Step 8: Remove the screw securing the air box to the fender, then pull the factory air box out of the truck.

**Figure D****Refer to Figure D for Step 9**

(The installation of the plastic vent tube insert is important to prevent check engine light. These procedures should be done with the turbo inlet tubes installed on the engine. It is shown off the vehicle for better illustration.)

Step 9: Locate the factory plastic tube feeding the driver's side turbo inlet. This is the connection closer to the turbo.



**Refer to Figure E for Step 10**

Step 10: Locate the valve cover vent tube that feeds into the driver's side turbo inlet. It is not necessary to remove the engine cover.



**Figure F****Refer to Figure F for Step 11**

Step 11: Note the release clip on the vent tube connectors. Apply pressure against the exposed tail and pull vent fitting off the turbo inlet tube. It is not necessary to disconnect at the valve cover end. There is a sensor and wire harness on this vent tube. Do not damage or remove these components.

INSTALL



Figure G

**Refer to Figure G for Step 12**

Step 12: Insert vent fitting with slash cut facing turbo. It should not be a loose fit. It is direction dependent and must not rotate once installed.

**Figure H****Refer to Figure H for Steps 13-14**

Step 13: Reconnect the vent fitting. It will snap over without having to release the plastic clip. Pull up slightly to confirm installation.

Step 14: Installation of the vent tube is complete. Any codes can be cleared with a code reader or by disconnecting the battery. You will lose any radio presets with battery disconnection.

If removal of the vent insert is required, it can be pulled out with internal snap rings pliers.

**Figure I****Refer to Figure I for Steps 15-16**

Step 15: Install the longer seal trim onto the top edge of the aFe POWER housing.

Step 16: Transfer the factory grommet and sleeve from the factory air box to the aFe POWER housing.



Figure J

**Refer to Figure J for Steps 17-20**

Step 17: Install the aFe POWER housing into the truck by pushing it into the factory mounting grommets.

Step 18: Secure it using the factory screw removed at step 8.

Step 19: Secure the front of the housing with the two provided plastic rivets.

Step 20: Reattach the wastegate accuator to the mount on the aFe POWER housing



Figure K

**Refer to Figure K for Step 21**

Step 21: Remove the filter clamp from the aFe POWER air filter. Slide the air filter into the aFe POWER housing from the top opening. Then guide the filter flange through the round opening in the housing and snap in the filter. Place the filter clamp on the filter flange but do not tighten at this time.

**Figure L****Refer to Figure L for Step 22**

Step 22: Remove the temperature sensor from the factory intake tube. Transfer it to the fitting onto the aFe POWER intake tube. Turn it clockwise until the tab locks it into place.



**Figure M**

**Refer to Figure M for Steps 23-24**

Step 23: Install the bellow coupling onto the driver side turbo inlet. Place the bigger clamps on it but do not tighten yet.

Step 24: Install the reducer coupling on the other turbo inlet and place the clamps on it but to not tighten at this time.





**Refer to Figure N for Steps 25-26**

Step 25: Install the aFe POWER intake tube into the filter flange then connect it to the two couplings.

Step 26: Align the tube and filter, then tighten all clamps.



Figure O

**Refer to Figure O for Step 27**

Step 27: Reconnect the temperature sensor harness.



Figure P

**Refer to Figure P for Step 28**

Step 28: Verify all clamps and connections are secured. Your installation is now complete. Thank you for choosing aFe POWER!



**advanced FLOW engineering, Inc.**

252 Granite Street Corona, CA 92879

<https://afepower.com/contact>