

advanced FLOW engineering Cold Air Intake System

Instruction Manual P/N: 57-10015D / 57-10015R

Make: Chevrolet	Model: Silverado 1500	Year: 2019-2023	Engine: V8-5.3L/6.2L
Make: Chevrolet	Model: Tahoe/Suburban	Year: 2021-2023	Engine: V8-5.3L/6.2L
Make: GMC	Model: Sierra 1500	Year: 2019-2023	Engine: V8-5.3L/6.2L
Make: GMC	Model: Yukon/Yukon XL	Year: 2021-2023	Engine: V8-5.3L/6.2L
Make: Cadillac	Model: Escalade	Year: 2021-2023	Engine: V8-6.2L



- Please read the entire instruction manual before proceeding.
- Ensure all components listed are present.
- For technical support please call 951-493-7185.
- Ensure you have all necessary tools before proceeding.
- Do not attempt to work on your vehicle when the engine is hot.
- Retain factory parts for future use.

Label	Qty.	Description	Part Number
A1	1	Air Filter (Pro 5R)	24-91120
A2	1	Air Filter (Pro DRY S)	21-91120
B	1	Tube	05-5710015C1
C	1	Housing	05-5710015B2
D	1	Coupling, Silicone Bellow: (3-1/2"x3-3/4")ID x 3"L	05-01508
E	1	Coupling, Silicone Bellow: 3-3/4"ID x 3"L	05-01509
F	2	Clamp, T-bolt (3-13/16" - 4-1/8")	03-50265
G	1	Clamp, T-bolt (3-9/16"-3-7/8")	03-50498
H	2	Screw, Torx: M4x10mm	03-50490
J	1	Seal, Trim: 3/4" Bulb (37"L)	05-01507
K	2	Ties, Nylon Cable Push Mount	03-50492
M	1	Hose, Silicone Breather 5/8" ID (18"L)	05-01502

Installation will require the following tools:

Panel clip remover, T-15 & T-20 Torx driver, 7mm & 8mm nut driver, small flat-head screwdriver, 10mm & 11mm deep sockets and driver.

Warranty Information available at <https://afepower.com/contact#warranty>

Emissions Disclaimer: This product is not currently CARB exempt and is not available for purchase in California or for use on any vehicle registered with the California Department of Motor Vehicles.

IMPORTANT: The Air Filter Life System needs to be reset to 100% and then disabled. Follow your owner's manual procedure titled "How to Reset the Engine Air Filter Life System" then disable the system entirely. Failure to disable the system may prompt a persisting "Check Engine Air Filter System" message.

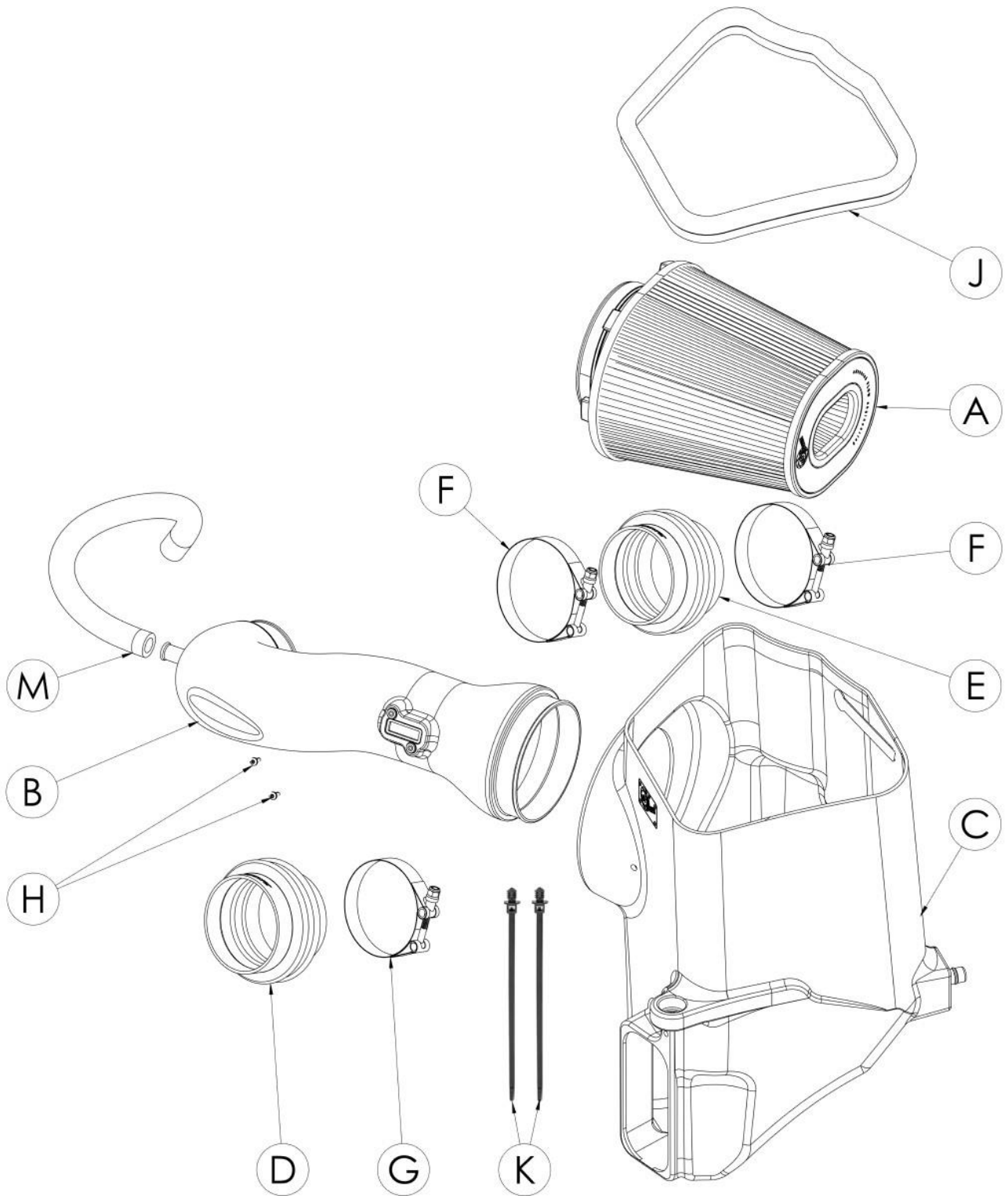

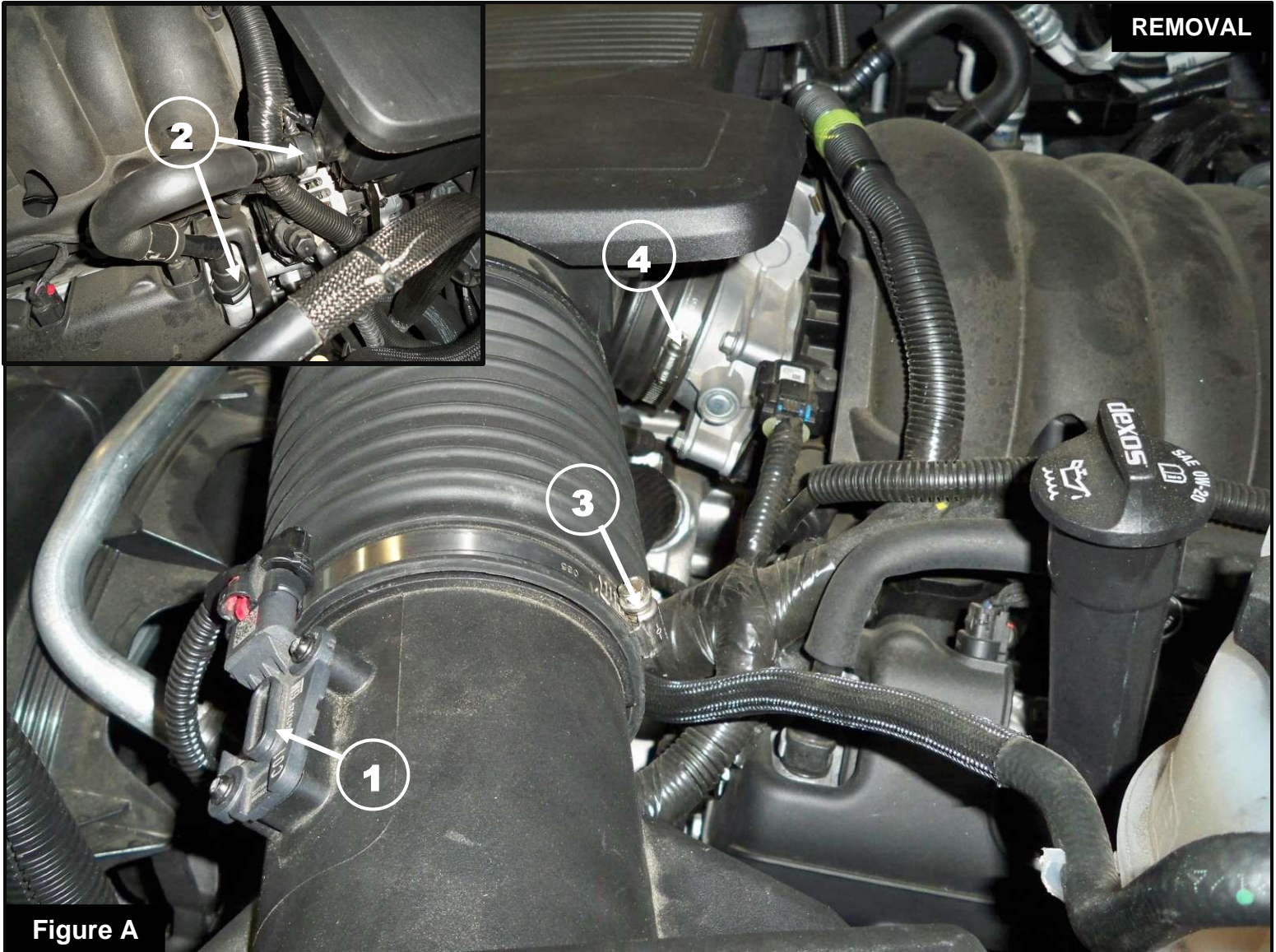

Refer to Figure A for Steps 1-3

Step 1: Disconnect the MAF sensor (1).

Step 2: Remove the crankcase breather hose (2) by pushing in both clips and pulling it out.

Step 3: Using a 7mm or an 8mm nut driver (depending on the truck), loosen the hose clamps at the factory housing (3) and the throttle body (4).

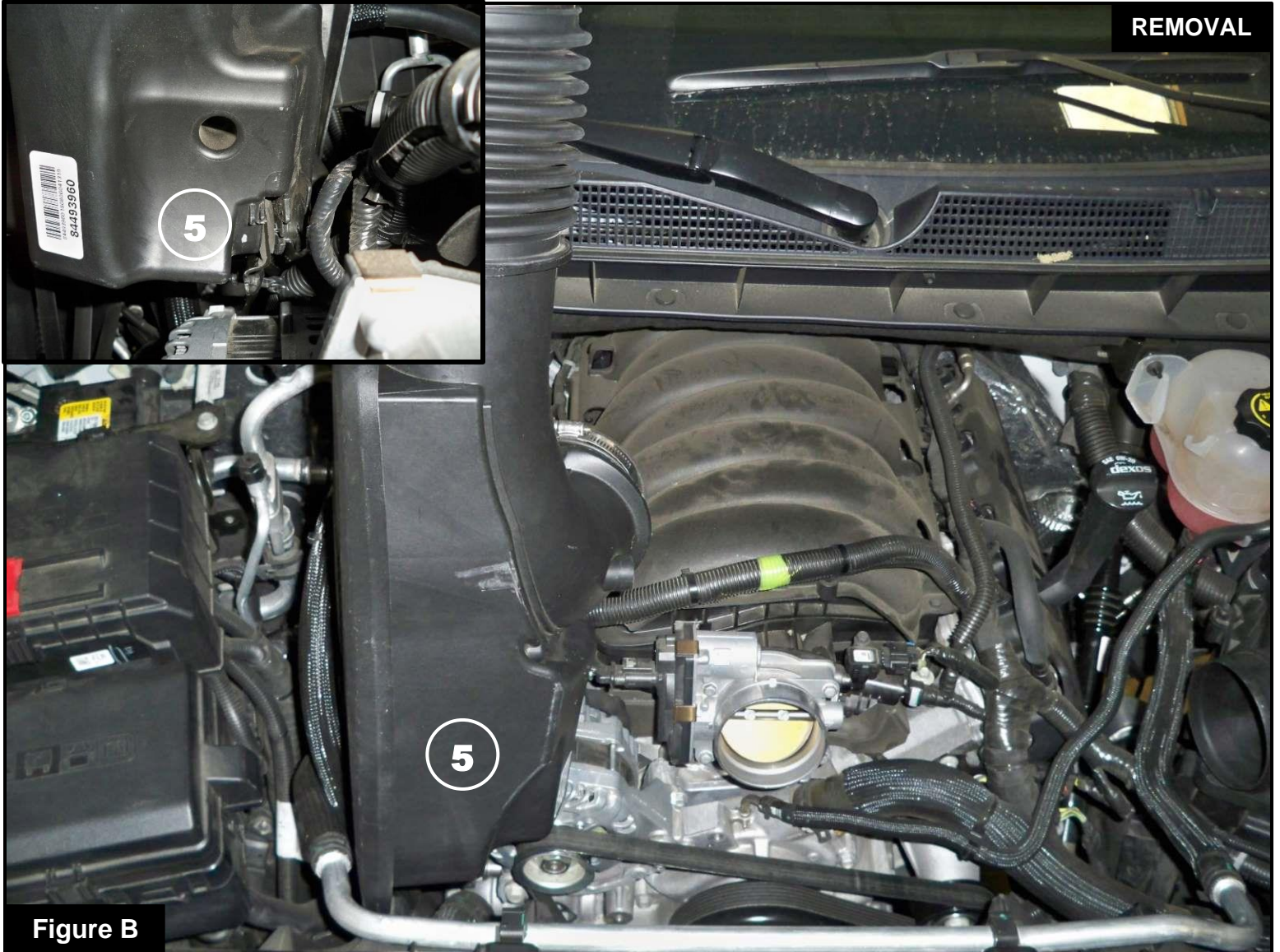
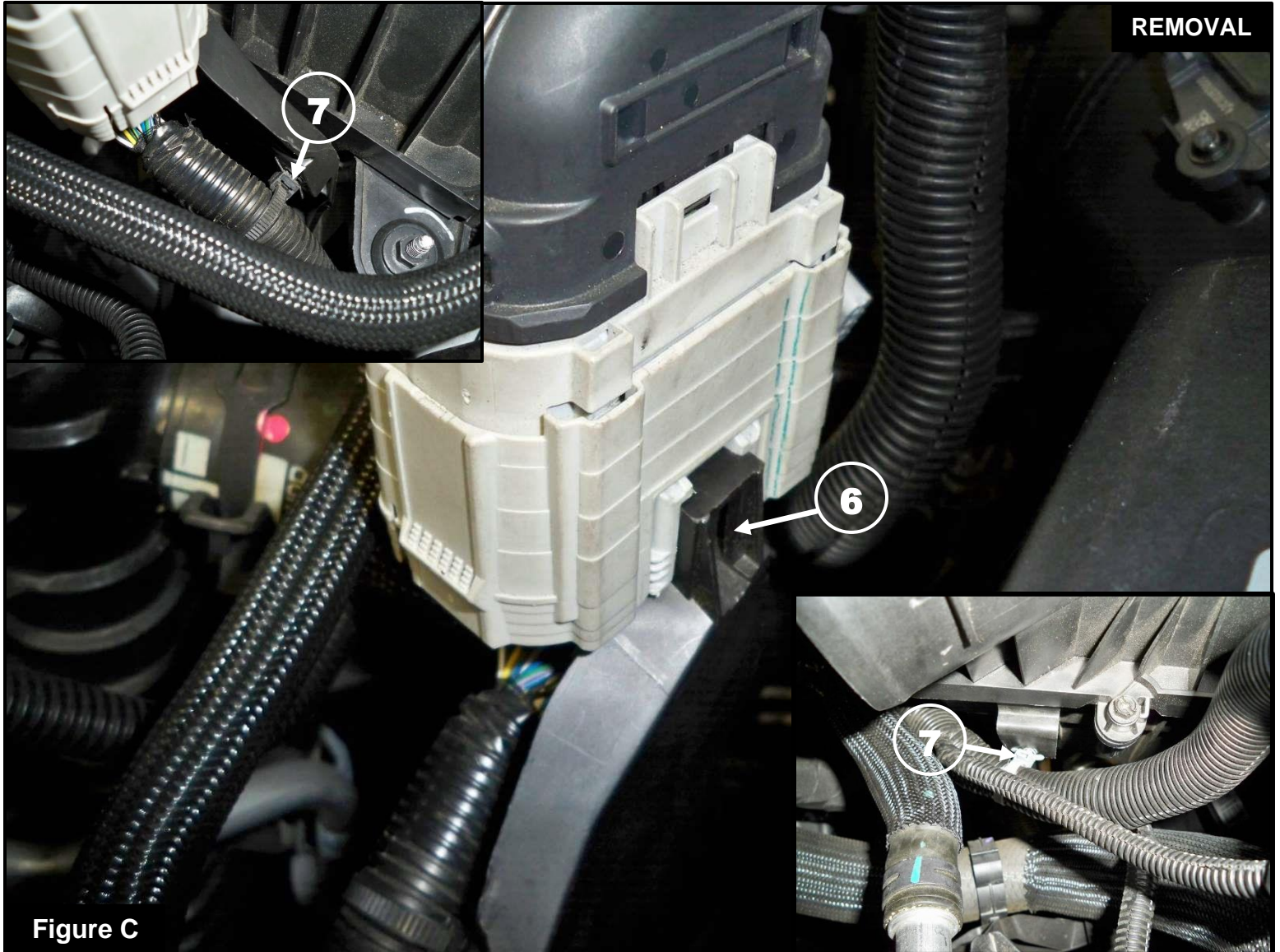

Figure B

Refer to Figure B for Step 4

Step 4: Remove the air cleaner outlet duct (5) by rotating it counterclockwise and snapping it out of the eyelet.



Refer to Figure C for Step 5

Step 5: Using a small flat-head screwdriver, release the locking tab at the wiring harness connector (6) and unsnap the two harness ties (7) then move the harness out of the way.

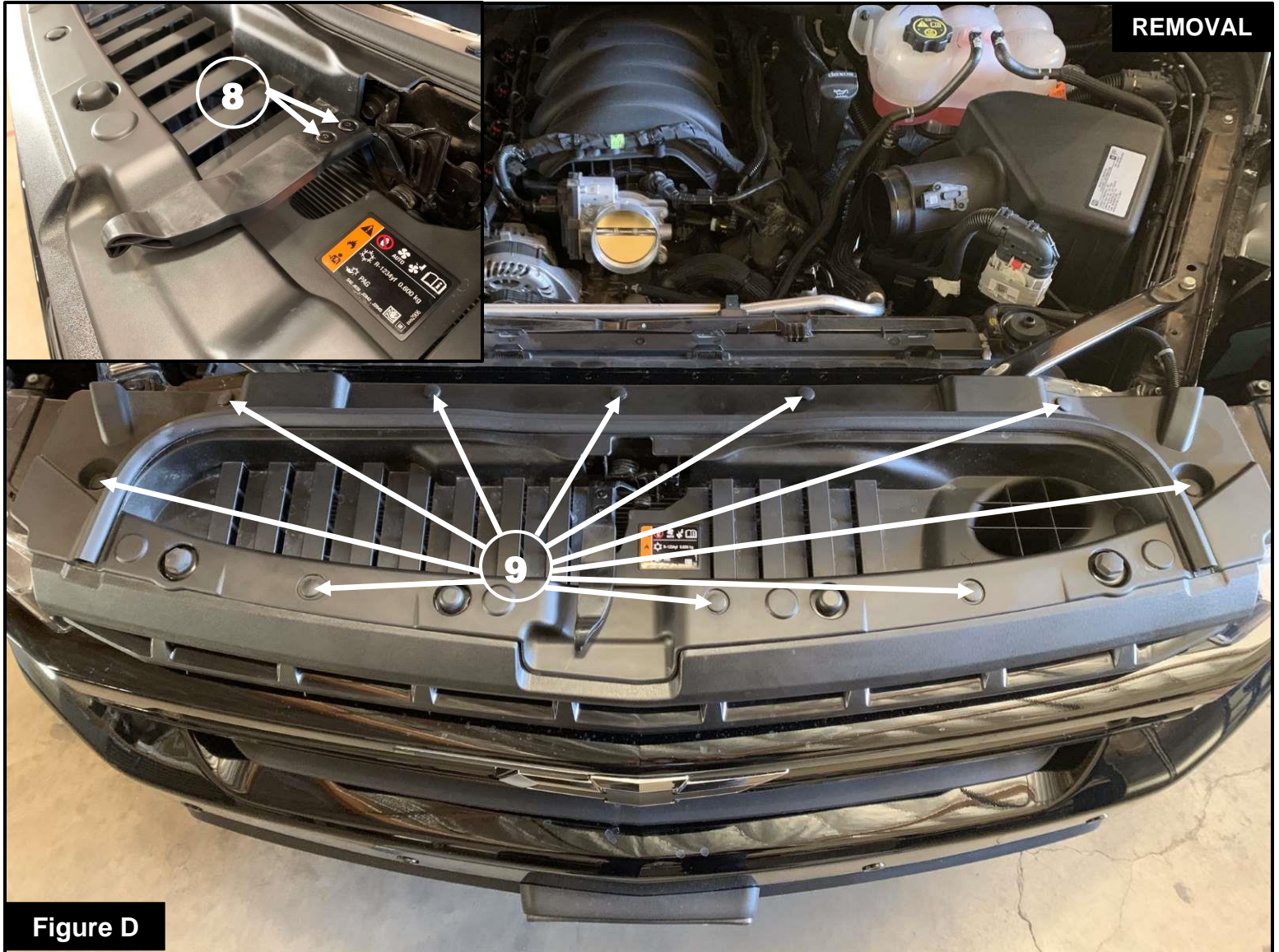
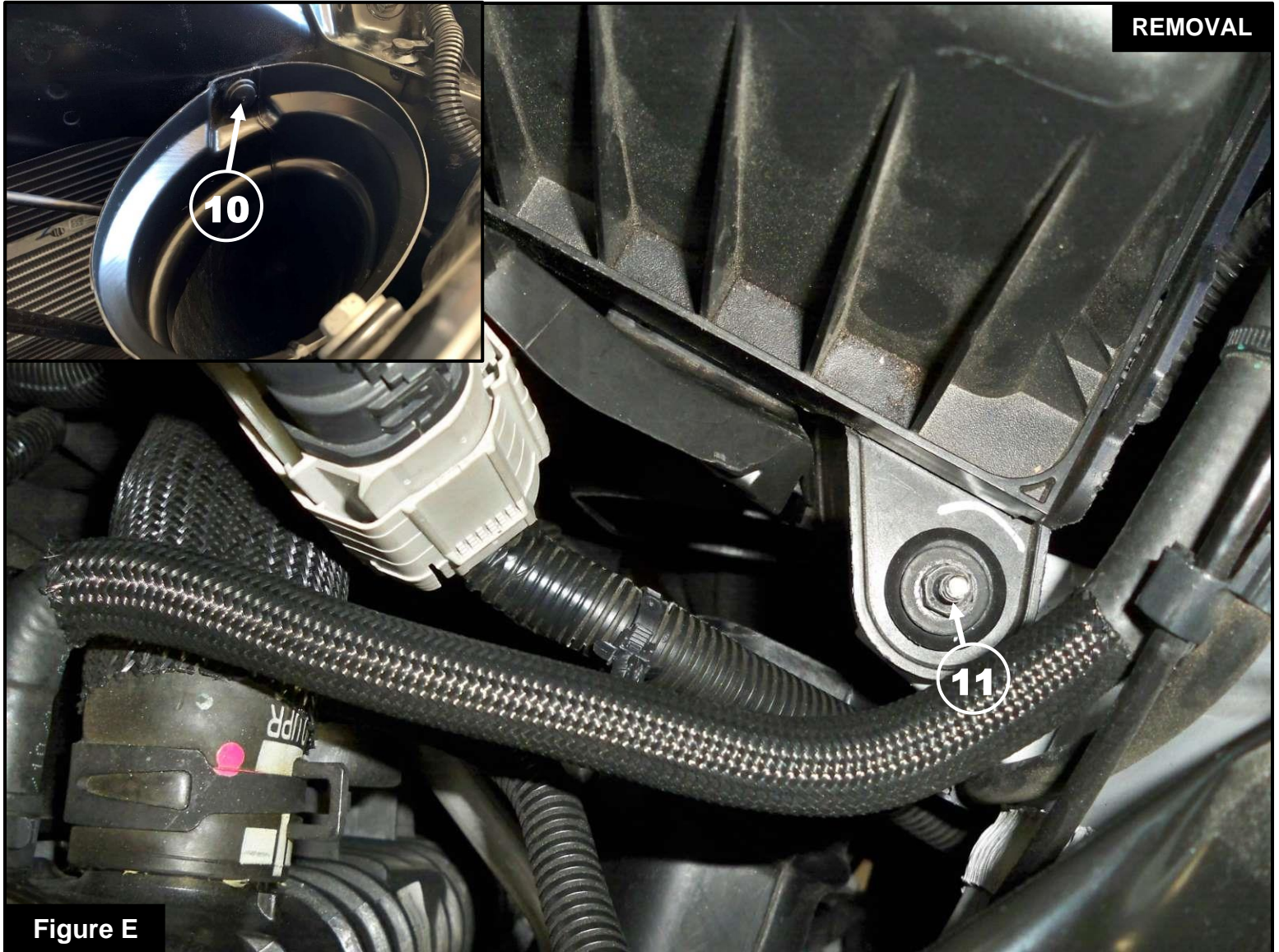

Figure D

Refer to Figure D for Steps 6-7

Step 6: Using a T-15 Torx driver, remove the two screws (8) securing the hood latch and then slide it out to remove. Set the screws aside.

Step 7: Using a panel clip remover, remove all ten panel clips (9) holding the sight shield. Remove the shield and set it aside with the clips.



Refer to Figure E for Steps 8-10

Step 8: Using the clip remover, remove the clip (10) that's holding the air scoop and set aside.

Step 9: Pull the air scoop out of the way from the stock housing.

Step 10: Using a 10mm deep socket and driver, remove the nut (11) that secures the factory housing to the vehicle.

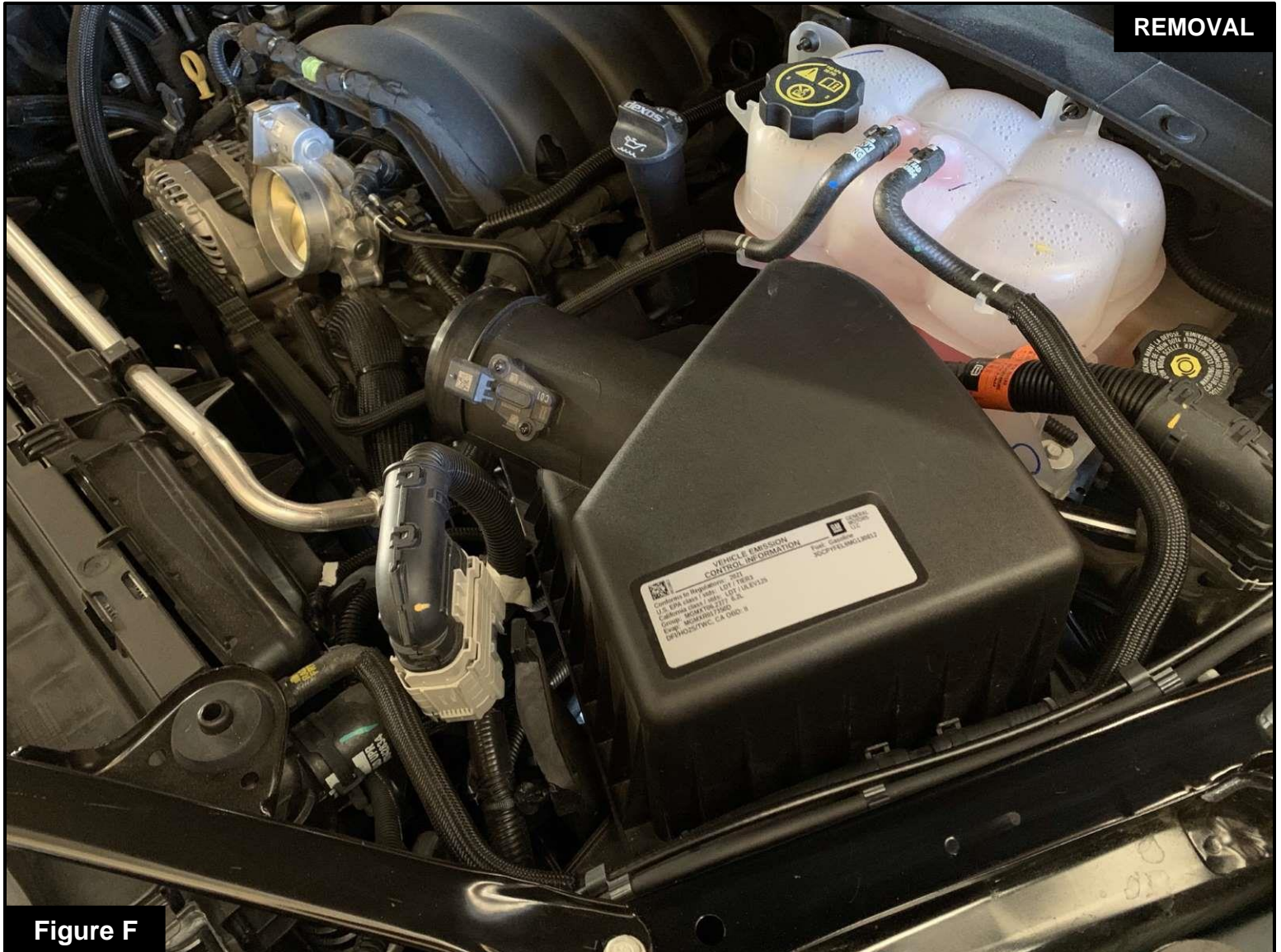

Figure F

Refer to Figure F for Step 11

Step 11: Remove the factory housing by pulling up out of the securing stud and towards the front of the vehicle. Two pins with grommets will have to come out of the holding bracket and a clear path is needed so that the air scoop is not in the way of the housing. Pull up on the factory housing to remove it from the vehicle.



Figure G

Refer to Figure G for Steps 12-13

Step 12: Remove the 2 grommets (12) from the factory housing pins and install them onto the aFe POWER housing.

Step 13: Remove the front metal insert and grommet (13) from the factory housing and install them into the aFe POWER housing.

**Figure H****Refer to Figure H for Step 14**

Step 14: Using a T-20 Torx driver, remove the MAF sensor (14) from the factory housing and install it on the aFe POWER intake tube using the supplied M4 screws.



Figure I

Refer to Figure I for Steps 15-17

Step 15: Install the seal trim (15) on the top opening of the aFe POWER housing as shown.

Step 16: Install the aFe POWER housing into the vehicle. Make sure the two pin grommets are secure inside the holding bracket and reinstall and tighten the nut (16) removed in Step 10.

Step 17: Slide the air scoop inside the front opening of the aFe POWER housing. Align the air scoop and reinstall the clip (17) removed in Step 8.



Figure J

Refer to Figure J for Steps 18-19

Step 18: Install the sight shield with all ten clips removed in Step 7.

Step 19: Install the hood latch with the two screws removed in Step 6 and tighten them.

**Figure K****Refer to Figure K for Step 20**

Step 20: Remove the filter clamp (18) from the aFe POWER filter. Slide the aFe POWER filter into the aFe POWER housing from the top. Then guide the filter flange through the round opening in the housing and snap in the filter. Place the filter clamp on the filter flange.

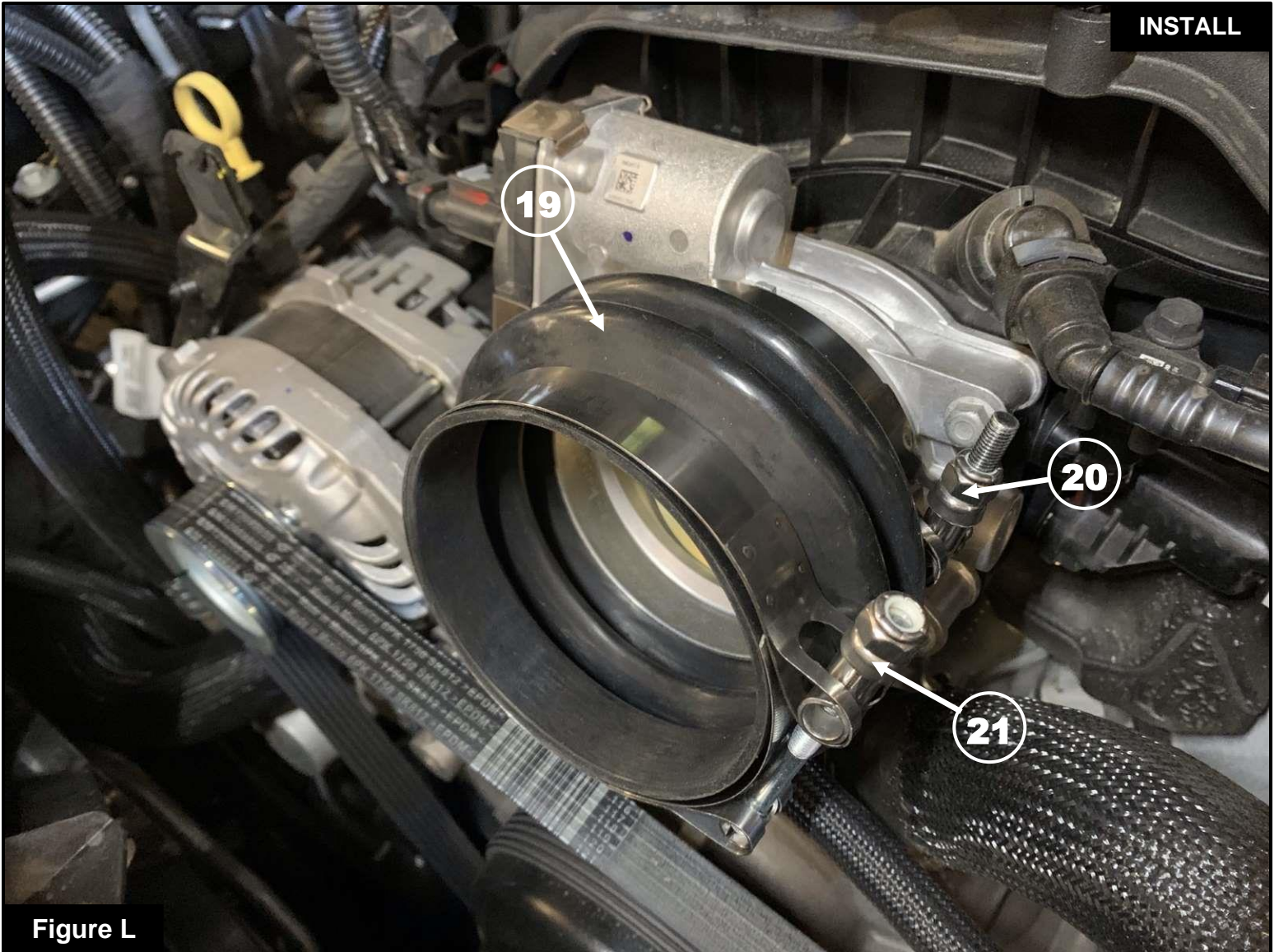
**Figure L****Refer to Figure L for Steps 21-22**

Step 21: Depending on the engine, place the supplied corresponding aFe coupling (19) and clamp (20) over the throttle body:

V8-6.2L= coupling 05-01509 & clamp TB412SS

V8-5.3L= coupling 05-01508 (smaller diameter opening goes on the throttle body) & clamp TB387SS

Step 22: Place a TB412SS clamp (21) on the other end of the coupling.

**Figure M****Refer to Figure M for Steps 23-24**

Step 23: Install the aFe POWER intake tube into the vehicle. Slide the tube into the throttle body coupling first, then into the air filter.

Step 24: Align the tube and clamps correctly, then using an 8mm nut driver tighten the filter clamp. Use an 11mm deep socket and driver to tighten the clamps at the coupling.

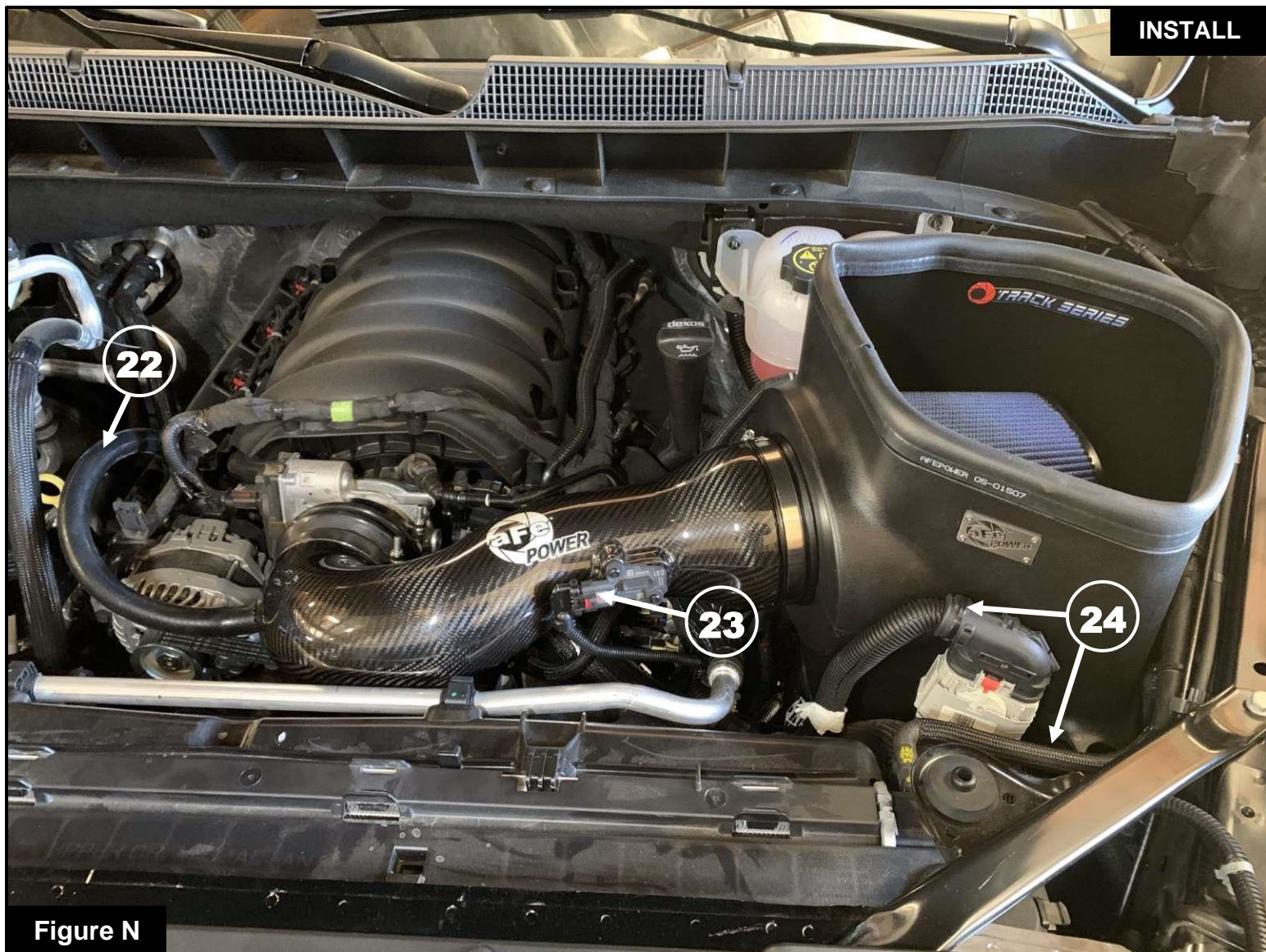
**Figure N****Refer to Figure N for Steps 25-28**

Step 25: Connect the supplied silicone crankcase breather hose (22) to the port on the aFe POWER intake tube and the other end to the port where the factory hose was removed.

Step 26: Reconnect the MAF sensor (23) .

Step 27: Use the supplied captive tie (24) to secure the wiring harness to the aFe POWER housing and snap the tie in the upper provided hole. Snap the factory tie on the harness into the hole by the air scoop.

Step 28: Check all the components are tight and secure. Your installation is now complete. Thank you for choosing aFe POWER!

NOTE: Check all bolts, clamps, and connectors after 100-200 miles.



Page left blank intentionally



Page left blank intentionally



advanced FLOW engineering, inc.

252 Granite Street Corona, CA 92879

<https://afepower.com/contact>